

ARB BED RACK

Part Number: **1780730**
Product **BED RACK CASE MOUNT**
Description:
Optional Kits **ARB CASE 270201**

WARNING

NOTE THE FOLLOWING:

- ◆ Vehicle accessories which are not properly fitted can be dangerous.
- ◆ Please read these instructions carefully prior to fitting, and comply with the instructions at all times.
- ◆ If in any doubt please contact your nearest ARB state office or the stockist from whom it was purchased.
- ◆ Do not use this product for any vehicle make or model, other than those specified by ARB.
- ◆ This product or its fixing must not be modified in any way.
- ◆ The installation of this product may require the use of specialized tools and/or techniques.
- ◆ It is recommended that this product is only installed by trained personnel.
- ◆ These instructions are correct as at the publication date. ARB Corporation Ltd. cannot be held responsible for the impact of any changes subsequently made by the vehicle manufacturer.
- ◆ During installation, it is the duty of the installer to check correct operation/clearances of all components.
- ◆ Work safely at all times.
- ◆ Unless otherwise instructed, tighten fasteners to specified torque.
- ◆ Check bolt torque after 500km & at regular service intervals.

ARB 4x4 ACCESSORIES

Corporate Head Office

42-44 Garden St
Kilsyth, Victoria
AUSTRALIA 3137

Tel: +61 (3) 9761 6622
Fax: +61 (3) 9761 6807

Australian enquiries
North & South American enquiries
Other international enquiries

sales@arb.com.au
sales@arbusa.com
exports@arb.com.au

www.arb.com.au

SAFETY

NET PAYLOAD FOR YOUR BED RACK CASE MOUNT

- ◆ The maximum load per CASE MOUNT is **30.0kg**.
- ◆ Latches must be locked before traveling.
- ◆ Any weight carried on the BED RACK will adversely affect its handling, particularly in cornering or in a cross-wind, the vehicle should therefore be driven with increased discretion.
- ◆ Regularly check the tightness of the securing clamps and the security of the load.
- ◆ Attention is directed to statutory requirements regarding maximum permissible projections from vehicles.
- ◆ If accessories are attached to the bed rack, one cross bar must be fitted at all times.

GENERAL CARE AND MAINTENANCE

By choosing an ARB BED RACK, you have bought a product that is one of the most sought after 4WD products in the world. Your BED RACK is a properly engineered, reliable, quality accessory that represents excellent value. To keep your BED RACK in original condition it is important to care and maintain it following these recommendations:

- As part of any pre-trip preparation, or on an annual basis, it is recommended that a thorough visual inspection of the BED RACK is carried out, making sure that all bolts and other components are torqued to the correct specification. Replace any components as necessary.



Please contact local Authorised ARB Stockist if you would like to have this service carried out on your behalf.

FITTING REQUIREMENTS

REQUIRED TOOLS FOR FITMENT OF PRODUCT:

METRIC SOCKET SET	Tape measure
TORQUE WRENCH Minimum 22Nm	TORX KEYS
DRILL AND Ø8.5mm DRILL BIT	DERURRING TOOL

HAVE AVAILABLE THESE SAFETY ITEMS WHEN FITTING PRODUCT:





Protective eyewear 	Hearing protection 
--	--

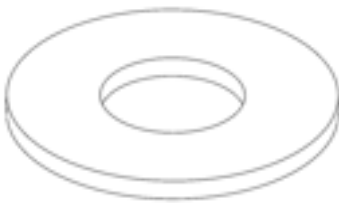
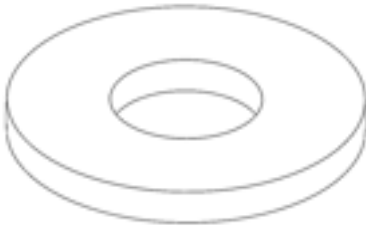

NOTE: 'WARNING' notes in the fitting procedure relate to OHS situations, where to avoid a potentially hazardous situation it is suggested that protective safety gear be worn or a safe work procedure be employed. If these notes and warnings are not heeded, injury may result.

FASTENER TORQUE SETTINGS:

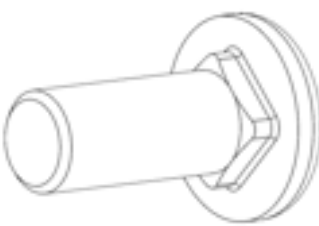
SIZE	Torque Nm	Torque lbft
M8	22Nm	16lbft

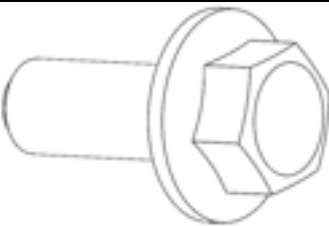
PARTS LISTING

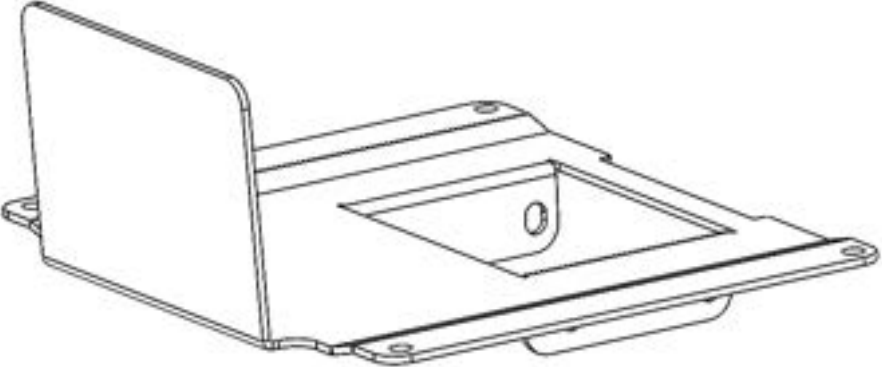
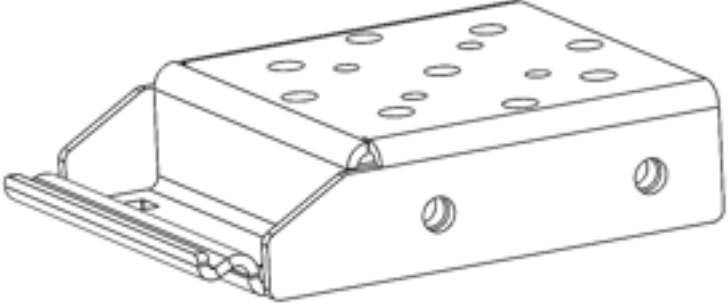
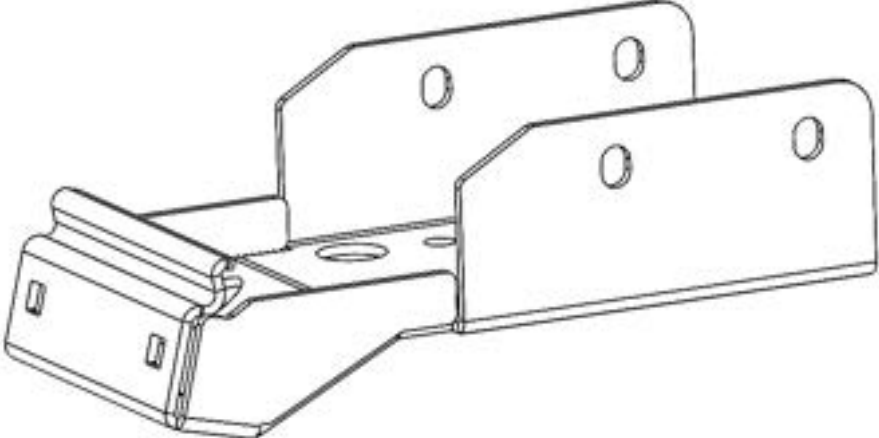
PART NUMBER	DESCRIPTION	QTY	DIAGRAM
4581085	WASHER FLAT M8X19X1.2	4	
4581307	WASHER FLAT M8x20x2 BZP BLACK	4	
6151212	NUT HEX NYLOC M8X1.25	8	
6151921	BOLT COHD M8X20	4	
4584415	WASHER FLAT M8x16x1.2 SS BONDED	8	
6151625	SCREW BHD M8x25 TX PC8.8 ZNB480 NYLON PATCH	4	
6151730	BOLT HXHD FL M8x1.25x20 FT PC8.8 BZP480	4	

3195783	INTERNAL SUPPORT PLT	1	
6582535	BED RACK COMP BOX MNT	1	
4655414	SINGLE MNT WELDMNT	1	
3755873	BRKT UNDER TWIN CLAMP	1	
3752562	BRKT RT ACC CLAMP 100MM	2	

BEFORE STARTING, READ ALL STEPS OF THE INSTRUCTIONS



1. Using the 6582535 mounting bracket as a template, drill $\text{Ø}8.5\text{mm}$ holes in each corner. Remove brackets and deburr all holes.



WARNING: Drilling & Cutting operations can result in flying debris. Eye and ear safety protection should be worn.

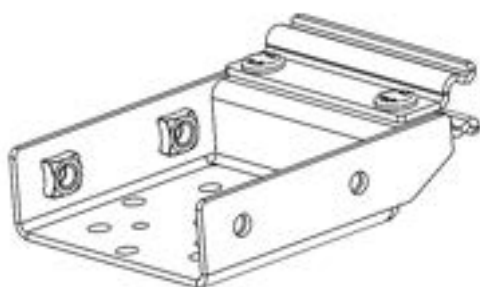

2. Assemble 3752562 to 4655414 as shown using two coach head bolts, M8 nyloc nuts and thin M8 washers. Ensure the head of the bolts are in the location shown.

Leave finger tight.

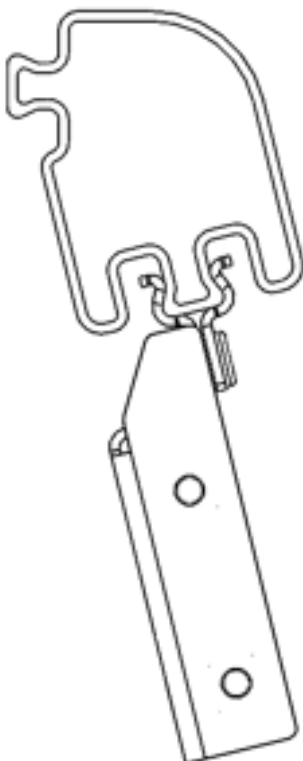

3. Install mount to internal dovetail. Tighten nyloc nuts enough to hold the mount while still being able to slide freely.

INSTALLATION WITH BED RACK CROSS BARS

SKIP TO STEP 6 FOR BASE RACK FITMENT

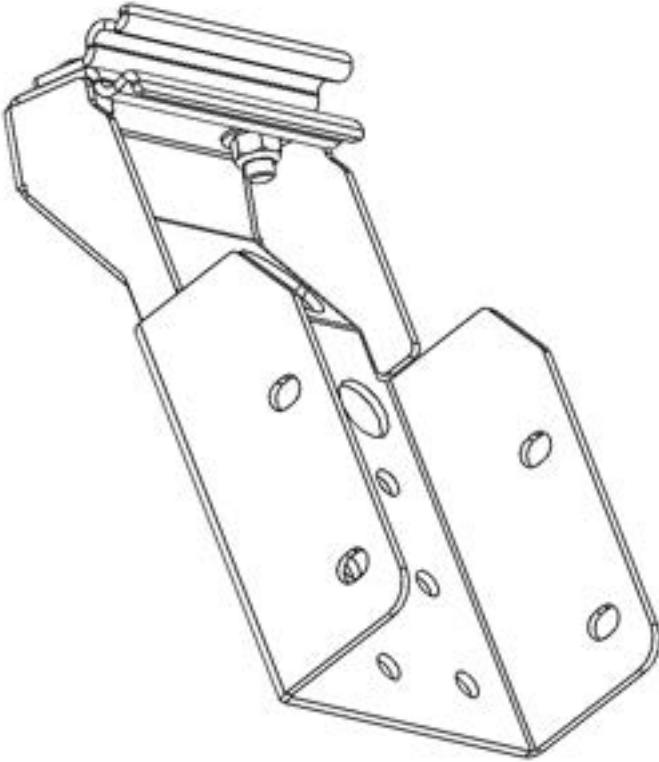

4. Assemble 3752562 to 3755837 as shown using two coach head bolts, M8 nyloc nuts and thin washers.

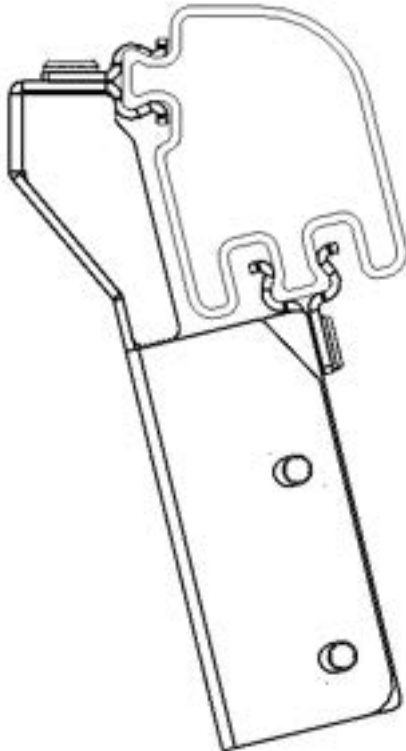

5. Fit larger mount over mount fitted in step 3, tighten M8 nyloc nuts to hold assembly in place.

INSTALLATION WITH BASE RACK

OTHERWISE SKIP TO STEP 9.

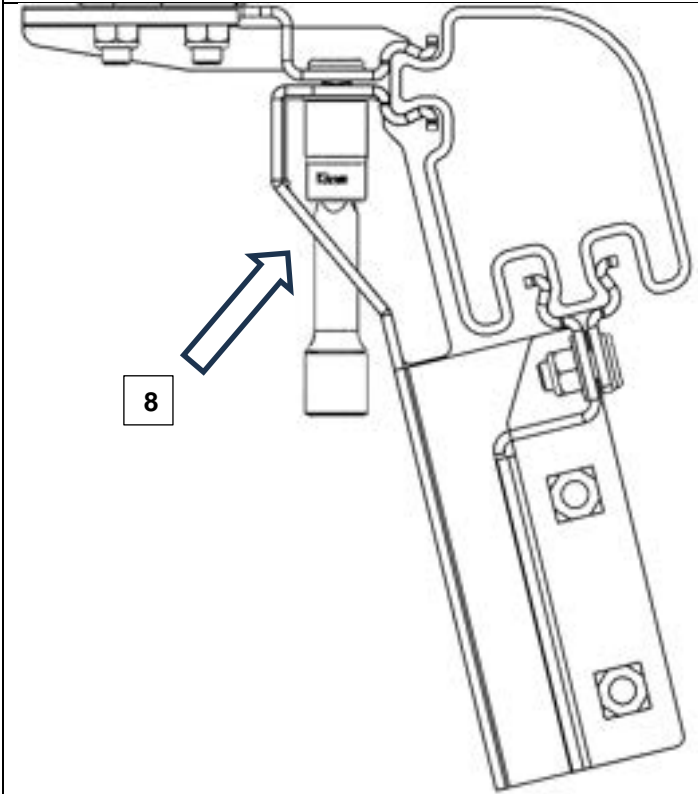

6. Remove lower dovetail clamp from Base Rack mounting bracket.
7. Align lower clamp with Base Rack mount.
8. Fit Large mount over lower clamp as shown and fit M8 washers and Nyloc nuts through access holes in mount. Leave loose.



9. Fit Case mounting plate over mounted brackets as shown using four M8 Flange head bolts. Leave loose.

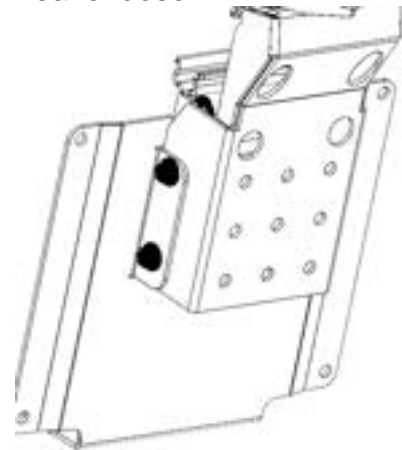

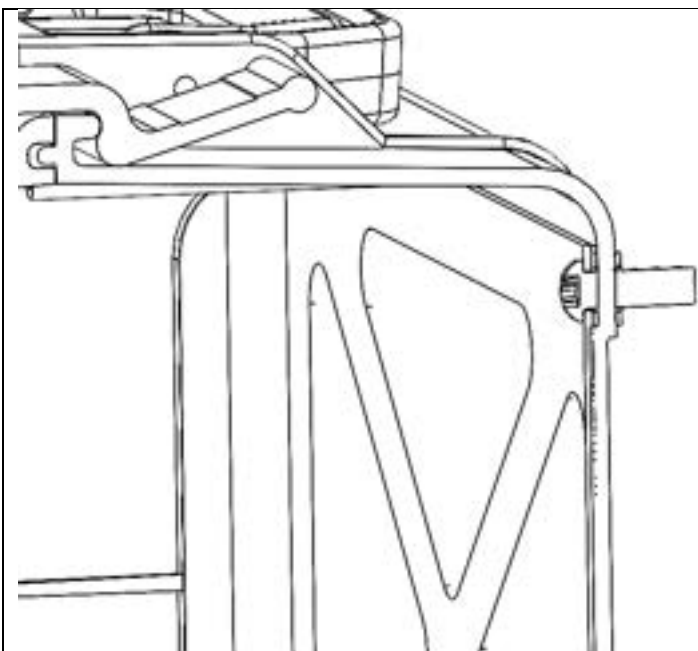

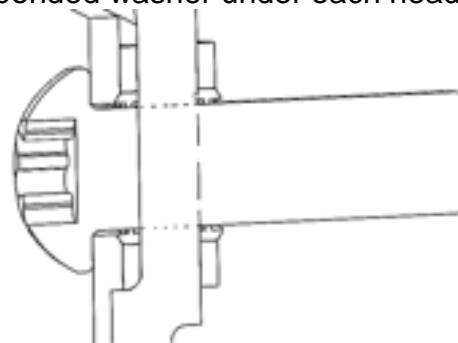

10. Fit four M8 button head screws to the internal support plate with one bonded washer under each head.

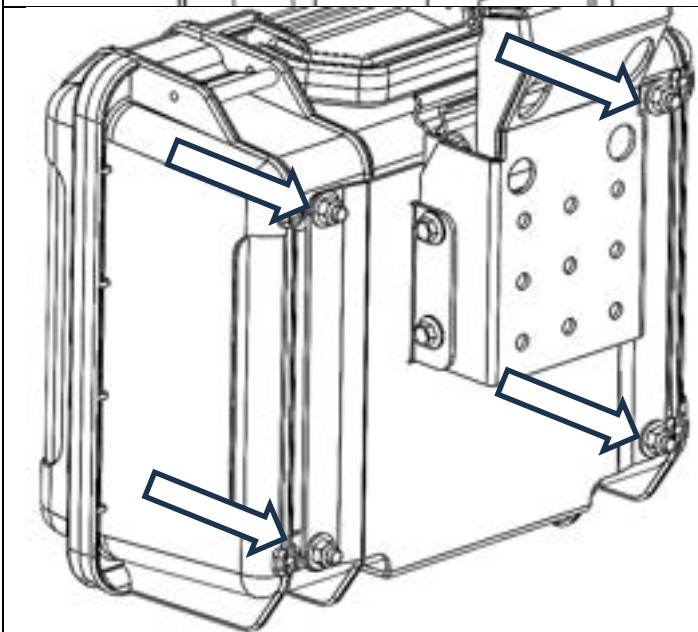

11. Place inside of case and fit one bonded washer to the outside of the case for each screw.



12. Fit assembled case to mounted plate using four M8 washers and M8 Nyloc nuts.
Torque to specification.

 M8 - 22 Nm.

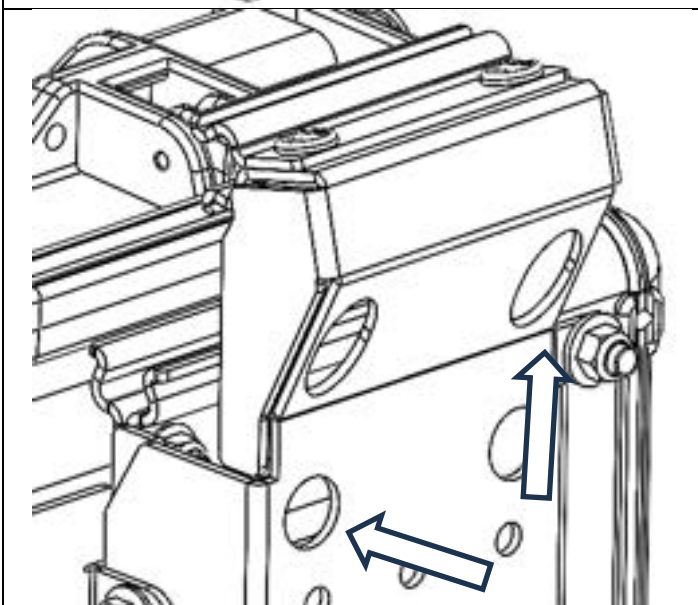

13. Tighten the four M8 Nyloc nuts through the access holes to specification.

 M8 - 22 Nm.

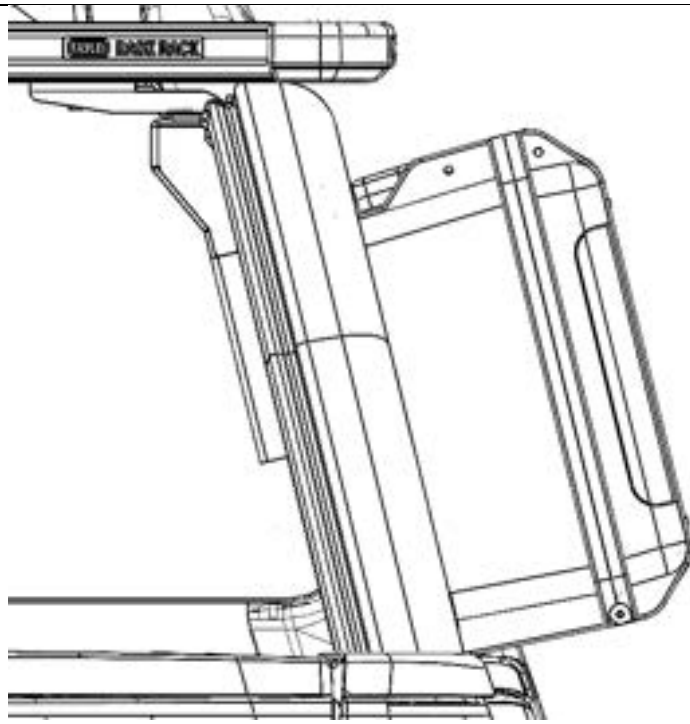

14. Align the case to be parallel with the Bed Rack frame and torque the four M8 flange headed bolts to spec.



M8 - 22 Nm.

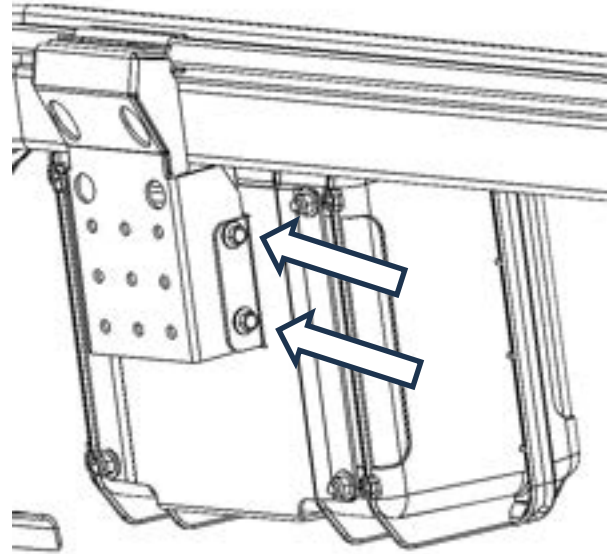

FITTED PRODUCT

