



FITTING INSTRUCTIONS

HILUX ARB BULL BAR, 2011 ONWARDS (SRS AIR BAG EQUIPPED MODELS)

PRODUCT NUMBER: -

341 4480 - Winch Bull Bar, to suit flared vehicles without fog option.

341 4490 – Winch Bull Bar to suit non-flared vehicles without fog option.

FITTING KIT: -

6173292

OPTIONAL FITTING KIT FOR WINCH FITMENT: 3514010

WARNING

NOTE THE FOLLOWING: -



- ◆ This product must be installed exactly as per these instructions using only the hardware supplied.
- ◆ In the event of damage to any bull bar component, contact your nearest authorized ARB stockist. Repairs or modifications to the impact absorption system must not be attempted.
- ◆ Do not use this product for any vehicle make or model, other than those specified by ARB.
- ◆ Do not remove labels from this bull bar.
- ◆ This product or its fixing must not be modified in any way.
- ◆ The installation of this product may require the use of specialized tools and/or techniques
- ◆ It is recommended that this product is only installed by trained personnel
- ◆ These instructions are correct as at the publication date. ARB Corporation Ltd. cannot be held responsible for the impact of any changes subsequently made by the vehicle manufacturer
- ◆ During installation, it is the duty of the installer to check correct operation/clearances of all components
- ◆ Work safely at all times
- ◆ Unless otherwise instructed, tighten fasteners to specified torque

GENERAL CARE AND MAINTENANCE

By choosing an ARB Bar, you have bought a product that is one of the most sought after 4WD products in the world. Your bar is a properly engineered, reliable, quality accessory that represents excellent value. To keep your bar in original condition it is important to care and maintain it following these recommendations:

- Prior to exposure to the weather your bar should be treated to a Canuba based polish on all exposed surfaces. It is recommended that this is performed on a six monthly basis or following exposure to salt, mud, sand or other contaminants.
- As part of any Pre Trip Preparation, or on an annual basis, it is recommended that a thorough visual inspection of the bar is carried out, making sure that all bolts and other components are torqued to the correct specification. Also check that all wiring sheaths, connectors, and fittings are free of damage. Replace any components as necessary. This service can be performed by your local authorized ARB Stockist.

HAVE AVAILABLE THESE SAFETY ITEMS WHEN FITTING PRODUCT: -

Protective eyewear 	Hearing protection 
--	--

NOTE: 'WARNING' notes in the fitting procedure relate to OHS situations, where to avoid a potentially hazardous situation it is suggested that protective safety gear be worn or a safe work procedure be employed. If these notes and warnings are not heeded, injury may result.

FASTENER TORQUE SETTINGS: -

SIZE	Torque Nm	Torque lb/ft
M6	9Nm	7lbft
M8	22Nm	16lbft
M10	44Nm	32lbft
M12	77Nm	57lbft

USE	PART No	QTY	DESCRIPTION
CONTROL BOX FITMENT (WINCH ONLY)	3756499	1	CONTROL BOX BRACKET
	6151234	2	BOLT, M8 x 1.25 x 25 LONG (BLACK)
	4581045	2	WASHER FLAT M8 (BLACK)
	6151132	2	NUT FLANGE M8
	180302	8	CABLE TIES
WINCH (8000/9000/9500 LB)	4581040	2	WASHER FLAT 3/8"
	6151074	2	BOLT UNC 3/8" x 1 3/4"
	BLB850	3	CABLE BLACK 850mm
	EG50	2	LARGE RUBBER GROMMET
IMPACT ABSORBER TO BULL BAR	6151304	4	NUT CAGE M10
	4581040	8	WASHER FLAT M10
	4581288	4	WASHER FLAT M10 (OVER-SIZED)
	4581048	8	WASHER, SPRING, M10
	6151232	8	BOLT, M10 x 1.5 x 30 LONG
	6151026	4	NUT, HEX, M10 x 1.5
BUFFERS TO BULL BAR	3162470R	1	BUFFER (RH)
	3162470L	1	BUFFER (LH)
	6151128	12	NUT FLANGE M6
NUMBER PLATE TO BULL BAR	6821189	2	GROMMET ROUND FL
	6151384	2	SCREW PAN HD PHIL BLK 5 X 16mm
INDICATORS TO BULL BAR	6821151R	1	INDICATOR KIT, RHS
	6821151L	1	INDICATOR KIT, LHS
	6821116	4	NYLON PLUG
	6151308	4	SCREW, SELF TAPPING
	6821152	2	WIRING LOOM
	6821198	1	INDICATOR RELAY LOOM
WING TRIM FITMENT	3163052R	1	TRIM, WING (LH), HILUX 11
	3163052L	1	TRIM, WING (RH), HILUX 11
	4581082	10	WASHER, FLAT, M6 (BLACK, 20 OD)
	6151384	2	PAN HEAD SCREW 5X16MM BZ
	6151162	8	NUT, NYLOC, M6x1
IMPACT ABSORBER TO CHASSIS	3756721	1	BRKT, CHASSIS MOUNT, HILUX 05
	4581040	4	WASHER, FLAT, M10
	4581048	4	WASHER, SPRING, M10
	6151133	4	NUT, M10 x 1.25
CHASSIS STIFFENING PLATE TO CHASSIS & IMPACT ABSORBER	3199756R	1	PLATE (RH), CHASSIS, HILUX 05
	3199756L	1	PLATE (LH), CHASSIS, HILUX 05
	6151088	6	BOLT, M10 x 1.25 x 35 LONG
	4581040	12	WASHER, FLAT, M10
	4581048	6	WASHER, SPRING, M10
	6151133	6	NUT, M10 x 1.25
LOWER GRILL BRACKET	3758129	1	BRKT GRILL MNT HILUX 05
	6151234	2	BOLT, M8 x 1.25 x 25 LONG (BLACK)
	4581045	2	WASHER, FLAT, M8 (BLACK)
	4581047	2	WASHER, SPRING, M8 (BLACK)
	6151132	2	NUT FLANGE M8

ITEMS SHOWN IN SHADED AREA ARE CONTAINED IN THE OPTIONAL WINCH FITTING KIT 3514010.

CENTRE STONE DEFLECTORS	6522649	1	PANEL STONE GUARD UPPER HILUX 05
	6522650	1	PANEL STONE GUARD LOWER HILUX 05
	6151303	8	CAGE NUT, M8 (3mm PLATE)
	4581045	8	WASHER, FLAT, M8 (BLACK)
	4581047	8	WASHER, SPRING, M8 (BLACK)
	6151234	8	BOLT, M8 x 1.25 x 25 LONG (BLACK)
WING STONE DEFLECTORS	6522816R	1	PANEL, WING (RH), HILUX 11
	6522816L	1	PANEL, WING (LH), HILUX 11
	6151315	10	CAGE NUT, M6 (1.6mm PLATE)
	4581082	10	WASHER, FLAT, M6 (BLACK, 20 OD)
	4581287	10	WASHER, SPRING, M6 (BLACK)
	6151213	10	BOLT, M6 x 1.0 x 20 (BLACK)
	6151094	2	BOLT M12 x 1.25 x 30 LONG
	4581049	2	WASHER, FLAT M12
	4581050	2	WASHER, SPRING M12
	6151234	2	BOLT, M8 x 1.25 x 25 LONG (BLACK)
	6151303	2	CAGE NUT, M8 (3mm PLATE)
	4581045	2	WASHER, FLAT, M8 (BLACK)
	4581047	2	WASHER, SPRING, M8 (BLACK)
	3758190R	1	BRACKET WING STONE SHIELD RH
	3758190L	1	BRACKET WING STONE SHIELD LH

Tools required: -

10 mm & 5 mm drill bits with power drill, Satin black can of spray paint, scissors or sharp knife, metric ruler, basic metric spanner and socket set & screw driver set, neutral cure silicon, and a stepped ring spanner to suit 3/8" bolt. (If installing a winch)

ASSEMBLY SEQUENCE FOR BULL BAR INSTALLATION.

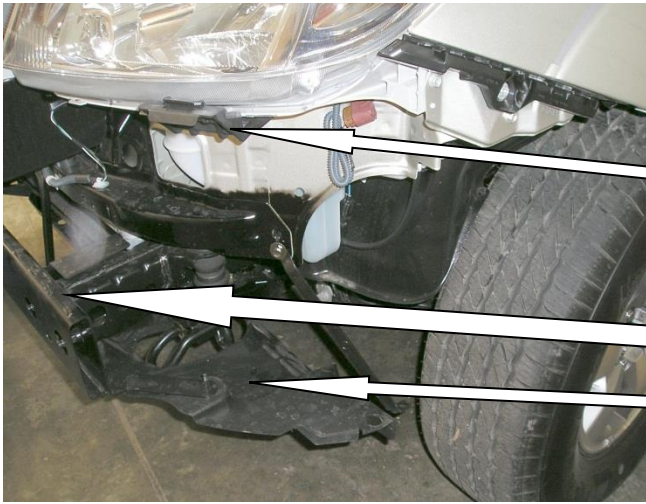

1. Remove existing bumper and grill from the vehicle.
Once these are removed:
 - Remove the light bracket fitting and discard; this is done by first removing the light and then unscrewing the bracket from the rear of the light fitting.
 - Remove the bumper braces and discard.
 - Remove the chassis cross-brace and discard.
 - Remove the factory fog lamps from the bumper bar and keep aside.

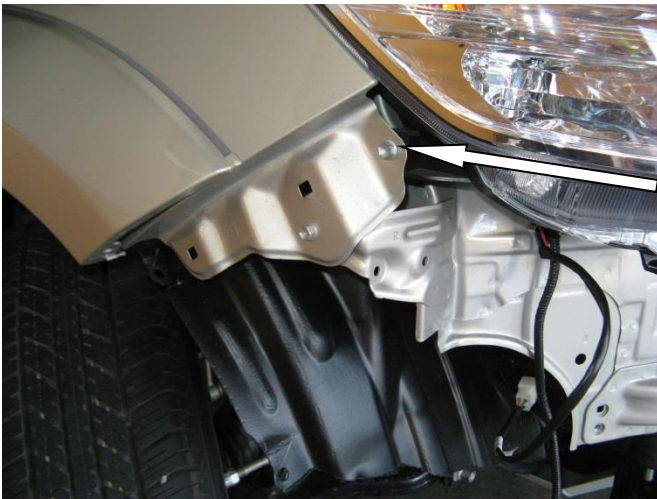

2. Remove the plastic bumper retention blocks from either side of the vehicle.
3. Replace the front most screws (these secure the head lights).



4. Spray paint the metal underside of the fender and the underside of the headlamp black.

Ensure the area to be painted is well masked to ensure no over spray on other components.



5. Remove the protruding bracket in front of the radiator, as it is no longer required (note: the vertical member of this bracket must not be removed as it holds the bonnet latch in position). This may be done by either drilling out the existing spot-welds with a 5mm drill as shown, or by cutting it off with a grinder. Re - locate the air temp sender (if fitted) to one of the holes in the vertical bracket.

Paint exposed metal to prevent rusting.

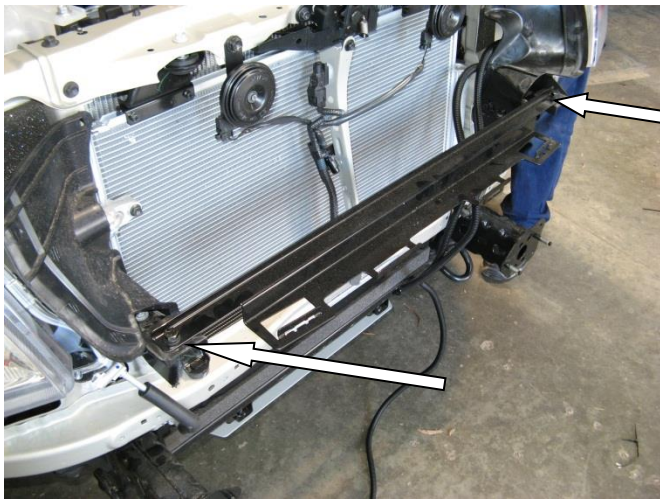

6. Fasten the lower grill bracket to the vehicle head lights, as shown, using M8 x 25 black bolts, flat washers, spring washers and flange nuts.



7. Reassemble the vehicle's grill removed at step 1; make sure the 2 lower grill tabs are pushed into the clips in the lower grill bracket. Bend lower grill bracket tab upwards slightly.



8. Remove the vehicles headlights.
9. Carefully read the wiring diagram supplied at the end of these instructions.
10. Take the relay loom (6821198) from the kit and position in the engine bay so that all wires will reach the appropriate connections.

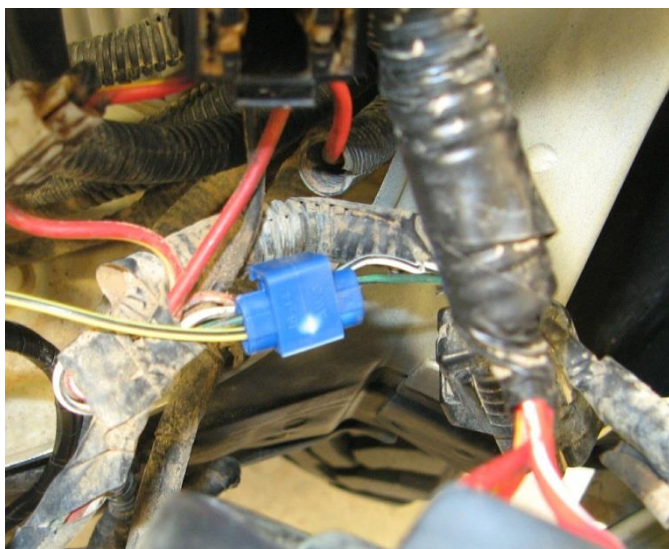

11. Starting with the passenger side, use scotch locks to connect the red wire from the indicator loom (6821152) to the green wire from the vehicles front park lamp.
12. Connect the Yellow / Black wire from the relay loom to the Green / Black wire from the vehicles left indicator.

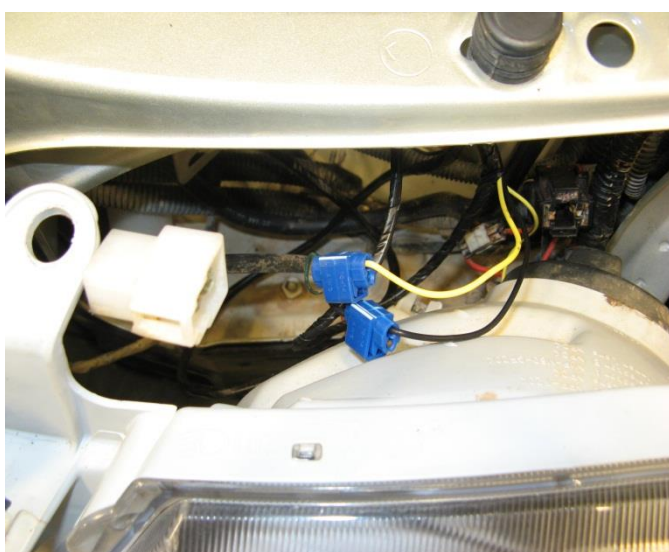

13. Connect the Yellow and Black wires from the relay loom to the Green and Black wires from the indicator loom.
14. Let the indicator loom hang freely for connecting to the bull bar indicators later on.
15. Do the same for the drivers side using the wiring diagram supplied as a reference for the correct wire colors.

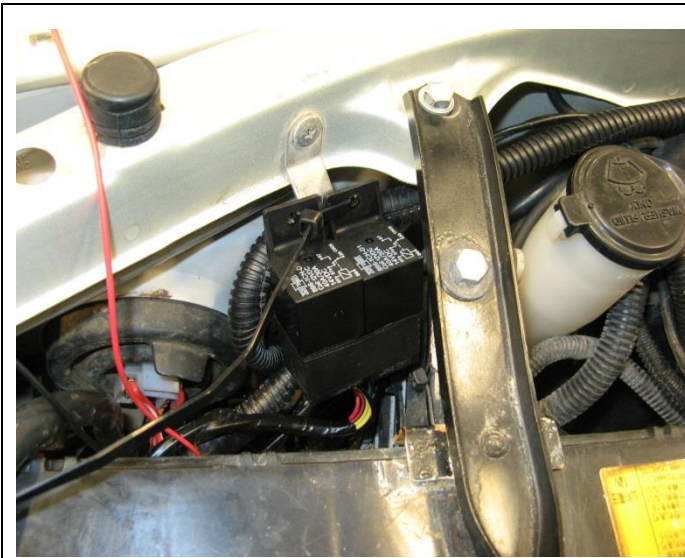

16. Find a suitable location and then mount the relay.

NOTE: Always mount the relay upright to help prevent water ingress.



17. Run the main black wire to a suitable earth.

18. Connect the main power wire (red) to the positive terminal of the battery. (Main battery if a dual battery system is installed)

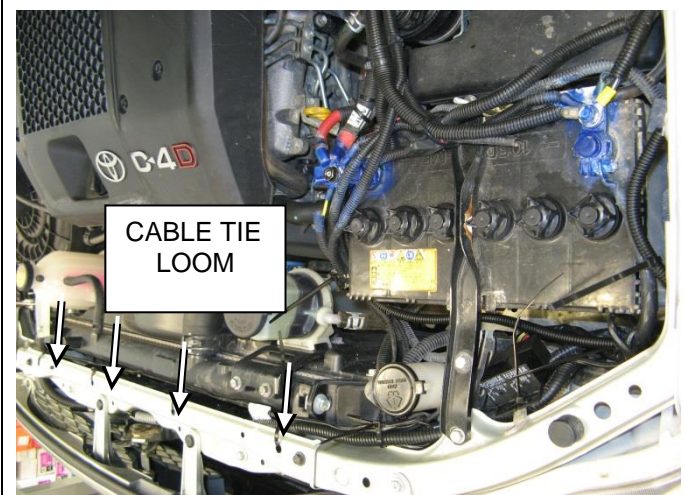

19. Using the cable ties supplied, secure the loom being sure to keep clear of any hot, sharp or moving surfaces.

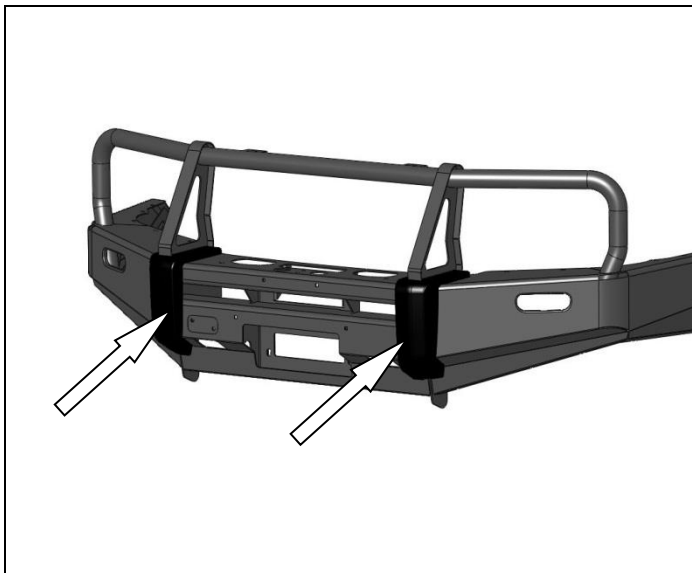

20. Fit the buffers to the bull bar using the 6mm flange nuts provided.

(DO NOT OVER TIGHTEN)

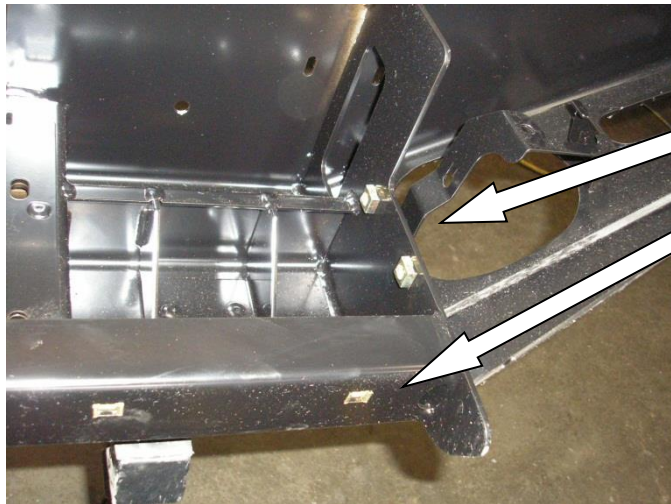

21. Fit cage nuts and nylon plugs to the bull-bar.

M10 cage nuts. (4 off) Caged portion is to centre of bull bar.

M8 cages nuts. (4 off) Caged portion is to top of bull bar.

Note: The bar shown in this picture suits fog lights. The fitment is the same on non-fog bars.



22. Loosely fit the wing trims using 5 oversized M6 washers, 4 x M6 nyloc nuts and 1 x self-tapping screw on each side of the bar

Note: These nuts will be tightened after the bar has been fitted to the vehicle and the wing trims have been positioned in an optimal position.

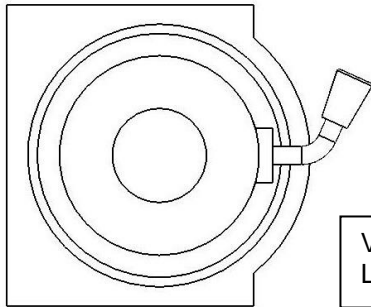

ORIGINAL

VIEWED FROM
LHS OF VEHICLE

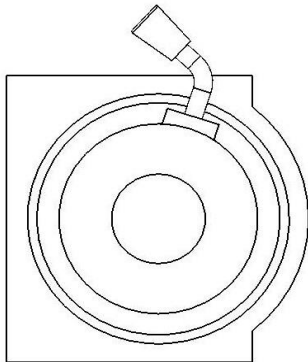

ROTATED

TO FIT A WINCH BAR

(If not fitting a winch proceed to step 51)

23. To fit an 8/9/9.5/000lb winch, rotate gearbox 72° counterclockwise.
24. Stand the winch upright and undo the capped head screws. Lift the gearbox up - only a couple of millimeters, to allow the gearbox to be rotated to the new position. Once in position, refit all screws and tighten firmly.

WARNING: Do not lift gearbox more than a couple of millimeters.

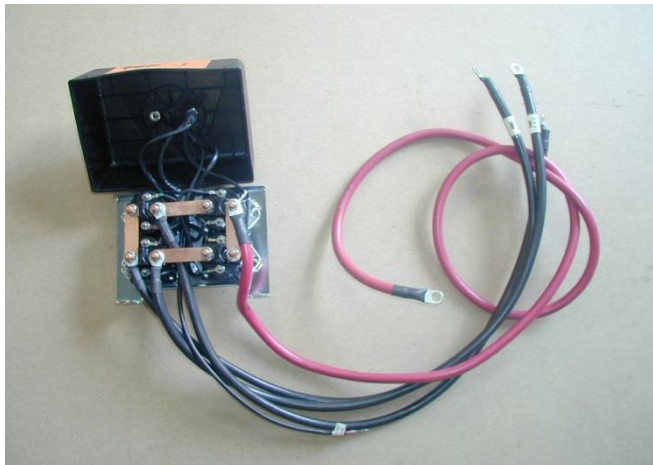

Note: The control box shown is an older style Warn model. The following 2 steps are required if fitting this or any other type of control box if the cables supplied are not long enough to reach from the winch to the control box.

25. Remove the cover from the control box.
26. Replace (if required due to lack of length) the 3 power cables that go from the winch to the control box. Make sure that you identify the colour / note code on the new cables before closing the control box cover.



27. Bolt the control box bracket to the control box.
28. Fit the two grommets into the round holes in the top of the bull bar then thread the cables through.
29. Mount the control box bracket onto the top pan, using M8 bolts, flat washers and flanged nuts. Use the cable ties to ensure the winch cables are secure, clear of moving parts and sharp edges and tie them together.

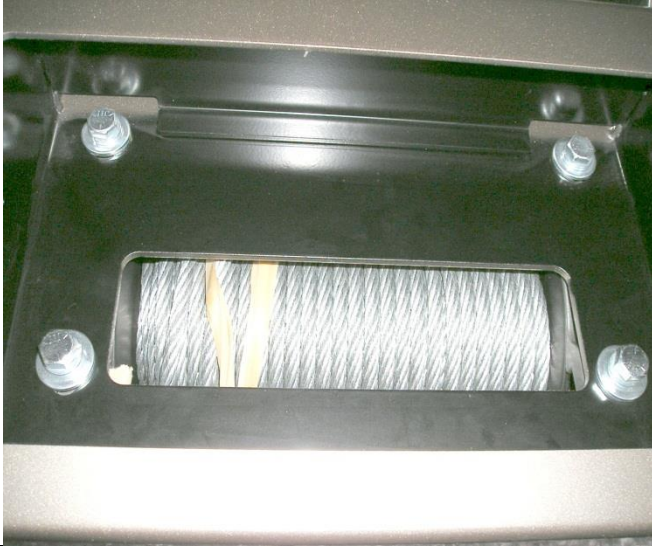

30. Place winch on a stand with mounting holes facing upwards and lower bull bar onto winch. Align all four holes, using the original 3/8" bolts that came with the winch in the top two holes and the longer 1 3/4" x 3/8" bolts, supplied in the kit, in the lower two holes plus 3/8" spring and flat washers with each bolt.

31. When all bolts are fitted and finger tight, tighten top holes only, using a stepped ring spanner and remove lower bolts.

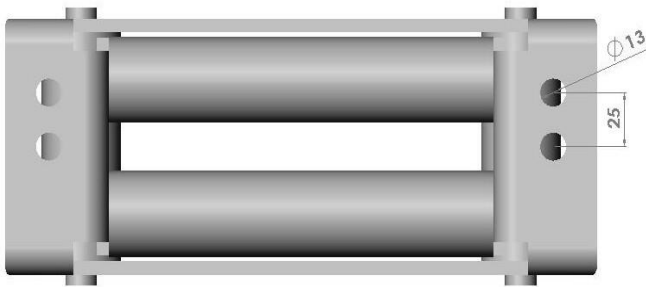

32. Drill two new Ø13mm holes in the roller fairlead provided in the kit, as shown on the adjacent picture.



33. Fit roller fairlead into cutout and refit bolts and tighten firmly.

NOTE. For ease of tightening the lower bolts, use a stepped ring spanner.



34. Connect the winch control box cables to the winch. Refer to Warn installation instruction manual when wiring up winch.
35. Ensure that all cables are installed well clear of all sharp or moving parts, by using cables ties from bolt kit.
36. Cable tie main cables that go to battery in between underside of bar and brace.

Refer to photo to see where to cable tie to bull bar.

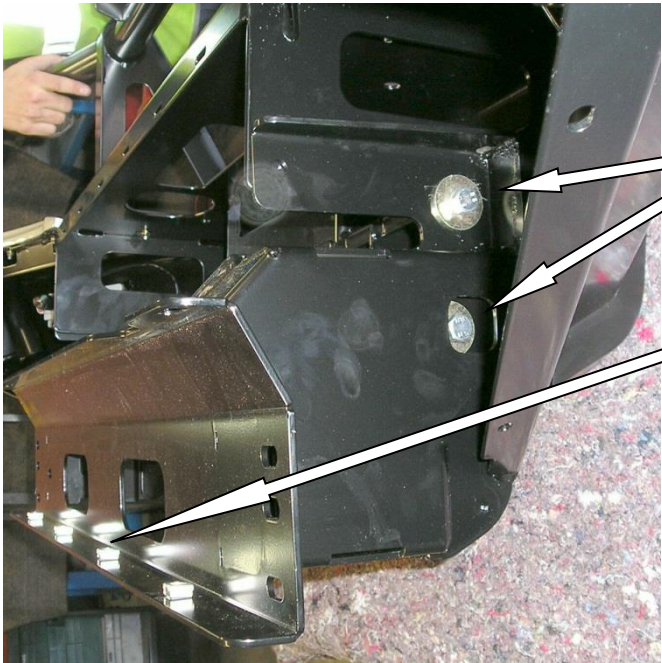

37. Fit the impact absorber to the bull-bar using the two M10 x 1.5P x 30 bolts as shown, M10 over-sized washers and M10 spring washers. Do not fully tighten these bolts as they will be tightened on the vehicle.

38. Fit four M8 cage nuts to the impact absorber. (Cage nuts to suite 3mm plate) Caged portion to top of bull bar.



39. Position the bar on the vehicle and fasten it to the chassis studs using the M10 washers, spring washers and nuts provided. Once satisfied that the bar is centrally positioned on the vehicle properly tighten the **M10x 1.25P** nuts.



40. Adjust the bull bar position up/down and in/out to achieve uniform gaps between the bar and the fenders on each side of the vehicle. The nominal clearance between the bull-bar and the fenders is 20mm. Tighten the bolts fitted at steps 37 & 40 to specified torque.

Note: The bar shown in this picture suits fog lights. The fitment is the same on non-fog bars.

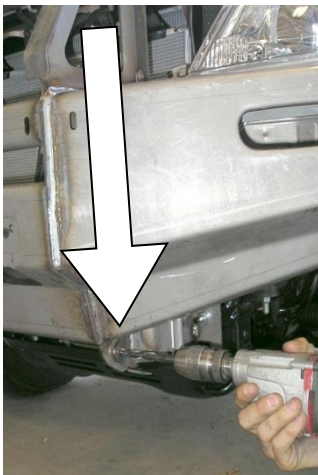

41. Once satisfied with the position of the bull-bar, using a Ø10mm drill, drill through the Ø10mm holes in the impact absorber, 2 holes per side, and secure using the M10 x 1.5P x 30 bolts, two flat washers per bolt, spring washers and M10 x 1.5P hex nuts.

CAUTION: Use suitable personal protective wear before commencing drilling operation

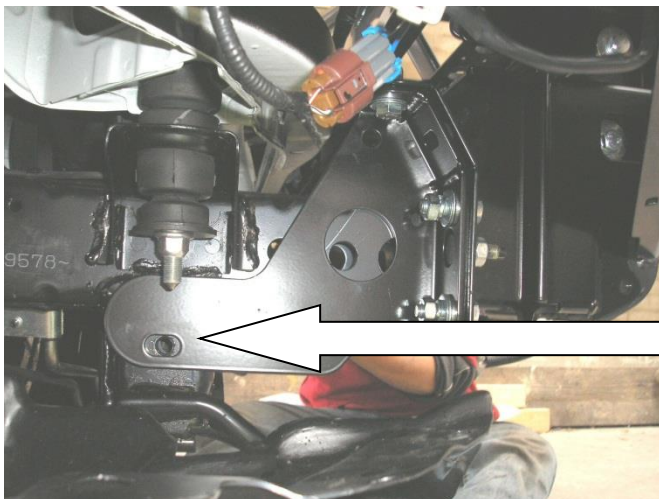

42. Fasten the chassis-stiffening bracket to the chassis and the impact absorber as shown. Fasteners required include: six **M10 x 1.25P x 35 bolts**, twelve M10 flat washers, six M10 spring washers, six **M10 x 1.25P** hex nuts

43. Tighten M10 fasteners to specified torque

Leave this bolt hole clear for step 47.

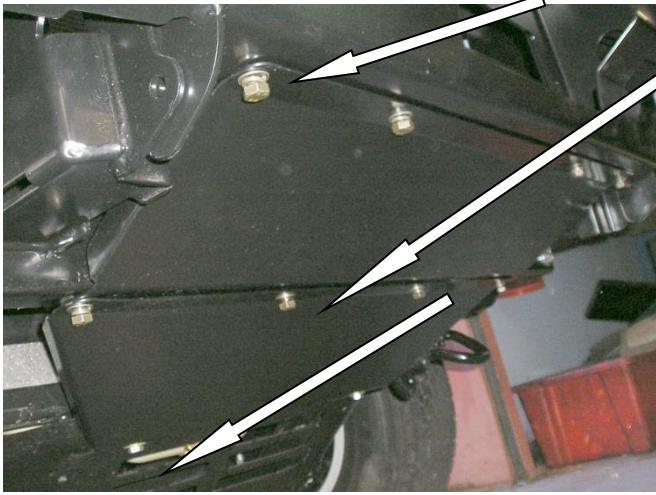

44. Fit the centre stone guards as shown using M8 x 25 black bolts, black M8 flat washers and black M8 spring washers.

45. Use the original bolts in the lower two holes.

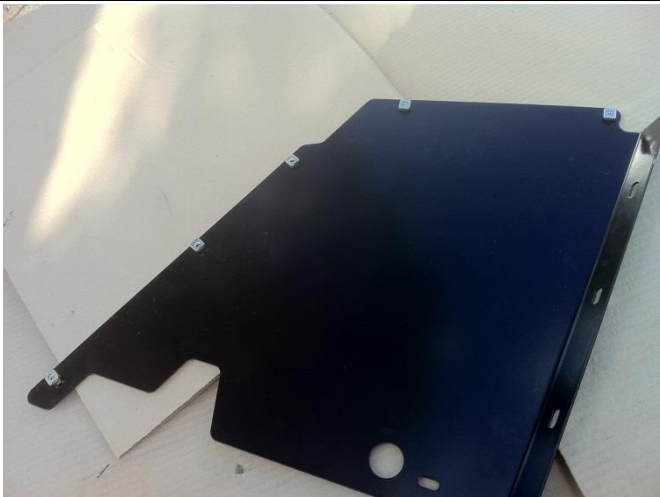

46. Fit the M6 cage nuts to the wing stone guards as shown.

NOTE: Make sure the plastic wheel liner on the LH side of the vehicle has been disconnected from the washer bottle before fitting the wing stone guards.

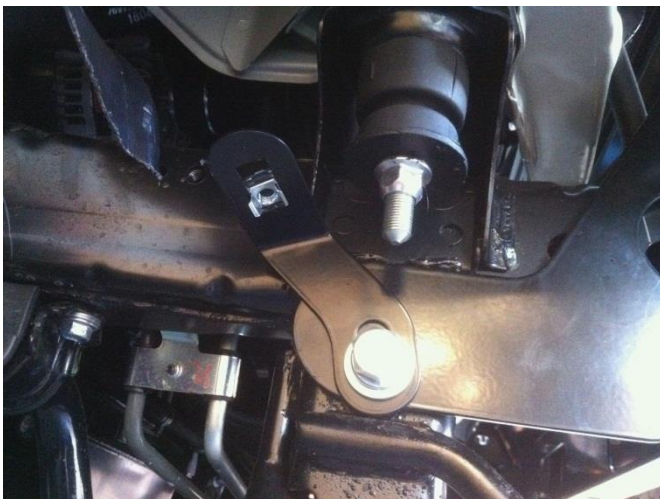

47. Fit the M8 cage nuts to the stone guard brackets.

48. Loosely fit the brackets to the side of the chassis rails using M12 x 30 Hex bolts, M12 Spring washers and M12 Washers.



49. Fit the wing stone guards to the bull bar / vehicle using M6 x 20 black bolts, M6 black washers, M6 black spring washers.

50. Use the M8 x 25 black bolt, M8 black flat washer and M8 black spring washer to secure the stone guard to the bracket fitted in step 47.

51. Fully tighten M12 and M8 fasteners to specified torque



52. Mark lines along the inner guards using the bottom edge of the stone guards as a guide.

53. Remove the stone guards and cut along the lines marked in the previous step. Tuck the inner guards into the stone guards.



54. If fitting optional driving lights to vehicle do so at this stage. Guide ratchet spanner between the upper and lower pans, as shown, to tighten the lights to the bar.





55. Fit the plastic plugs into the square holes in the lower or upper pan depending on fitment. Fit the number plate to the bull bar using the black self-tapping screws.

Note: The two photos display the number plate positions for both winch and non-winch bars.

BAR FITTED TO THE VEHICLE



NOTE: ARB UVP and Recovery point also fitted.

