



FITTING INSTRUCTIONS

Part Number: **3414700**

Description: **HILUX ROGUE SUMMIT MKII BULL BAR**

Suited to
vehicle/s: **Toyota Hilux Rogue 11/22ON**

Optional

Fitting Kits: **3501130 – WINCH INSTALL KIT SUMMIT**
3501070 – SUMMIT RFL COVER MATT BLACK | DOES NOT SUIT 200 OR Y62
3514140 – CAMERA RELOCATION

WARNING

REGARDING VEHICLES EQUIPPED WITH SRS AIRBAG;

When installed in accordance with these instructions, the front protection bar does not affect operation of the SRS airbag.

ALSO, NOTE THE FOLLOWING:

- ◆ This product must be installed exactly as per these instructions using only the hardware supplied.
- ◆ In the event of damage to any bull bar component, contact your nearest authorised ARB stockist. Repairs or modifications to the impact absorption system must not be attempted.
- ◆ Do not use this product for any vehicle make or model, other than those specified by ARB.
- ◆ Do not remove labels from this bull bar.
- ◆ This product or its fixing must not be modified in any way.
- ◆ The installation of this product may require the use of specialized tools and/or techniques.
- ◆ It is recommended that this product is only installed by trained personnel.
- ◆ These instructions are correct as at the publication date. ARB Corporation Ltd. cannot be held responsible for the impact of any changes subsequently made by the vehicle manufacturer.
- ◆ During installation, it is the duty of the installer to check correct operation/clearances of all components.
- ◆ Work safely at all times.
- ◆ Unless otherwise instructed, tighten fasteners to specified torque.

ARB 4x4 ACCESSORIES

Corporate Head Office

42-44 Garden St
Kilsyth, Victoria
AUSTRALIA, 3137

Tel: +61 (3) 9761 6622
Fax: +61 (3) 9761 6807

Australian enquiries
North & South American enquiries
Other international enquiries

sales@arb.com.au
sales@arbusa.com
exports@arb.com.au

www.arb.com.au

GENERAL CARE AND MAINTENANCE

By choosing an ARB Bar, you have bought a product that is one of the most sought after 4WD products in the world. Your bar is a properly engineered, reliable, quality accessory that represents excellent value. To keep your bar in original condition it is important to care and maintain it following these recommendations:



- Prior to exposure to the weather your bar should be treated to a Carnuba based polish on all exposed surfaces. It is recommended that this is performed on a six monthly basis or following exposure to salt, mud, sand or other contaminants.
- As part of any Pre Trip Preparation, or on an annual basis, it is recommended that a thorough visual inspection of the bar is carried out, making sure that all bolts and other components are torqued to the correct specification. Also check that all wiring sheaths, connectors, and fittings are free of damage. Replace any components as necessary. This service can be performed by your local authorized ARB Stockist.

FITTING REQUIREMENTS

REQUIRED TOOLS FOR FITMENT OF PRODUCT:

BASIC TOOL KIT	ELECTRIC DRILL WITH COMPLETE METRIC DRILL SET
JIG SAW OR OSCILATING MULTITOOl WITH BLADE SUITABLE FOR PLASTIC	LOW TACK MASKING TAPE
FILE	UTILITY KNIFE
TAPE MEASURE	CLAMP
STEEL RULE	WHITE FELT MARKER
HACK SAW	TORQUE WRENCH
TOUCH UP PAINT ANTI CORROSION	RIGHT ANGLE ELECTRIC DRILL

HAVE AVAILABLE THESE SAFETY ITEMS WHEN FITTING PRODUCT:

Protective eyewear		Hearing protection	
--------------------	---	--------------------	---

NOTE: 'WARNING' notes in the fitting procedure relate to OHS situations, where to avoid a potentially hazardous situation it is suggested that protective safety gear be worn or a safe work procedure be employed. If these notes and warnings are not heeded, injury may result.

FASTENER TORQUE SETTINGS:

SIZE	Torque Nm	Torque lbft
M6	9Nm	7lbft
M8	22Nm	16lbft
M10	44Nm	32lbft
M12	77Nm	57lbft

PARTS LISTING

APPLICATION.	PART NO.	QTY	DESCRIPTION
MOUNTS TO VEHICLE	3194818	4	PLATE NUT ASSY HILUX BAR 15ON
	3759666L	1	BRKT CHASSIS IN HILUX 15ON LHS
	3759666R	1	BRKT CHASSIS IN HILUX 15ON RHS
	3759667L	1	BRKT CHASSIS OUT HILUX 15ON LH
	3759667R	1	BRKT CHASSIS OUT HILUX 15ON RH
	4581007	2	WASHER FLAT 1/2x1 1/2x4mm TZP SILVER T
	4581040	16	WASHER FLAT M10x25x3 TZP480
	4654475L	1	MNT BRKT ASSY SUITS HILUX LHS
	4654475R	1	MNT BRKT ASSY SUITS HILUX RHS
	6151094	2	BOLT HXHD M12x1.25x30 PC8.8 ZP
	6151428	10	NUT FLANGE M12x1.75 PC8.8 SERRATED
	6151752	12	NUT FLANGE M10x1.5 PC8.8 BTZP480
	6151965	12	BOLT HXHD FL M10x1.5x30 PC8.8 ZNB480
	6152127	18	BOLT HXHD FL M12x1.75x30 PC8.8 ZNS480
BUFFERS & MOULDINGS	3163289	1	GRILLE CENTRE, SUIT SUMMIT
	3163294	1	KIT, CVR STRAP SUIT SUMMIT
	3163295	1	KIT, GRILLE OUTER SUIT SUMMIT
	3753105	2	BRKT GRILL MOUNT
	4584329	4	WASHER FLAT M6x12.2x1.2 BTZP480
	6151173	4	NUT FLANGE M6 ZNB480 SERRATED
	6151459	4	SCREW BHD M6x16 BTZP480
UNDER PANELS	6151301	4	NUT CAGED M8 3.3-4.7 1238-C
	6151526	10	NUT CAGED M6 1.8-2.7 BZP480
	6151655	3	NUT FLANGE M8x1.25 PC8 TZP480 ENS 14/002
	6151730	7	BOLT HXHD FL M8x1.25x20 FT PC8.8 BZP480 ENS14-001
	6152008	10	BOLT HXHD FL M6x1.0x25 PC8.8 ZNB480
	6523580	1	PANEL CENTER SUIT HILUX MKII
	6523620L	1	PANEL WING UNDER SUIT ROGUE L
	6523620R	1	PANEL WING UNDER SUIT ROGUE R
WINCH COVER PANEL FITMENT (IF NO WINCH IS FITTED)	4584329	8	WASHER FLAT M6x12.2x1.2 BTZP480
	6151213	4	BOLT HXHD M6x1.0x20 PC8.8 ZNB480
	6151223	4	NUT HEX NYLOC M6x1.0 ZNB480
	6523538	1	PANEL WINCH COVER 115MM
NUMBER PLATE	4584329	2	WASHER FLAT M6x12.2x1.2 BTZP480
	5848302	2	PACKER RB NYLON
	6151173	2	NUT FLANGE M6 ZNB480 SERRATED
	6151459	2	SCREW BHD M6x16 BTZP480

PARTS LISTING - CONTINUED			
LIGHTS & SENSORS	3500991	1	LAMP CLUSTER, ARB SUMMIT RH&LS LAMP SET
	3514130	1	SENSOR SURROUND KIT SUMMIT MKII HILUX
	6151173	4	NUT FLANGE M6 ZNB480 SERRATED
	6151300	2	NUT CAGED M6 2.6-3.5 956-C
	6152008	4	BOLT HXHD FL M6x1.0x25 PC8.8 ZNB480
	6152094	2	SCREW PHD M6x1.0x30 PC8.8 TX ZNB 480
	6821454	1	LIGHTING HARNESS FOG CLUSTER SUIT MKII SUMMIT HILUX 20 ON
	3755237L	1	BRKT SUPPORT FOG CLSTR ROGUE L
	3755237R	1	BRKT SUPPORT FOG CLSTR ROGUE R
MISC	180302	8	CABLE TIE 4.8 X 180 MM BLACK
	6191030	1	PINCH WELD 520mm
	6602018	1	ALCHOL SWAB SINGLE SACHET
	665044	1	3M PRIMER STICK
	6781408	1	TAPE DOUBLE SIDED 0.8 x 15 x 300
TEMPLATE	37801263	1	TEMPLATE BUMPER CUT 3414700 SUIT MKII HILUX ROGUE MY 22
	37801264	1	TEMPLATE FLARE CUT 3414700 SUIT MKII HILUX ROGUE MY 22



Note: Read the instructions thoroughly before starting.

1. Open the bonnet and remove all scrivenets (8) retaining plastic cover. Set aside scrivenets removed for re-use later on.

HINT: Depress centre to remove.

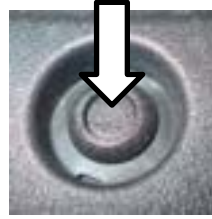

2. Remove plastic cover from above grille and set aside, this will be reused.



3. Remove upper grille retaining screws (4). Set aside for re-fitment later on.

Remove centre grille retaining screw (see arrow)
Set aside for re-fitment later on.



4. Gently unclip and pull back the top outside corners of the grille to reveal two screws retaining grille as well as one behind the radar. Using an extension and socket, remove and set aside for re-fitment later on.





5. Remove all fasteners and scrivenets retaining bumper along inside edge of wheel arches – (Right hand side shown).

Set aside for re-fitment later on.



6. Remove all fasteners and scrivenets retaining bumper along lower lip – (Left Hand side shown).

Set aside scrivenets and fasteners used to attach bumper to OEM stone deflector for re-use later on.



7. Remove mud flap fasteners, and retain fasteners.



8. Remove dressing piece from underside of bumper and discard.

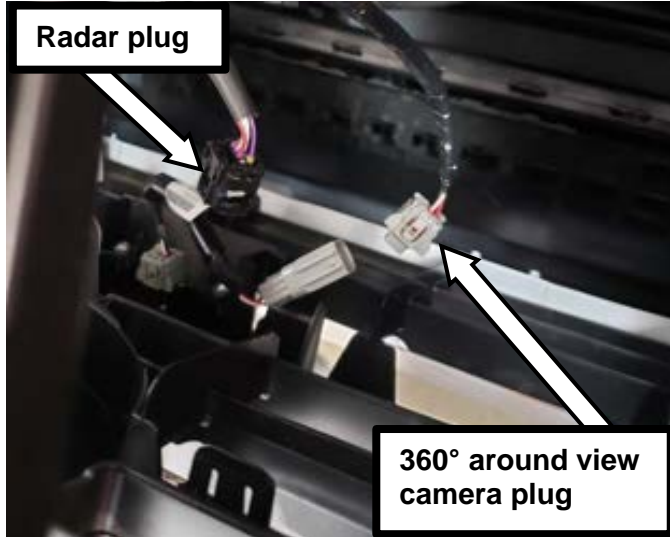

9. Locate Toyota Safety sense and 360° around view camera plugs (positioned behind the badge on the grille), and unplug from their respective units prior to proceeding.



10. Ensure inner guards are unclipped from front bumper.



11. Reach up from the wheel liners, and disconnect the fog light wiring and front parking sensors – (Right Hand side shown).





12. Remove registration plate and set aside, then carefully remove bumper from vehicle by pulling on each side of the bumper near the wheel arches and working your way towards the centre.

Set grille and bumper aside on a soft non-marking surface for re-use later in the fitment procedure.



13. Using a paint pen or white marker, label each parking sensor (Left or Right) prior to removing from bumper.

Once marked, unclip parking sensors (2) from bumper and store for reuse.

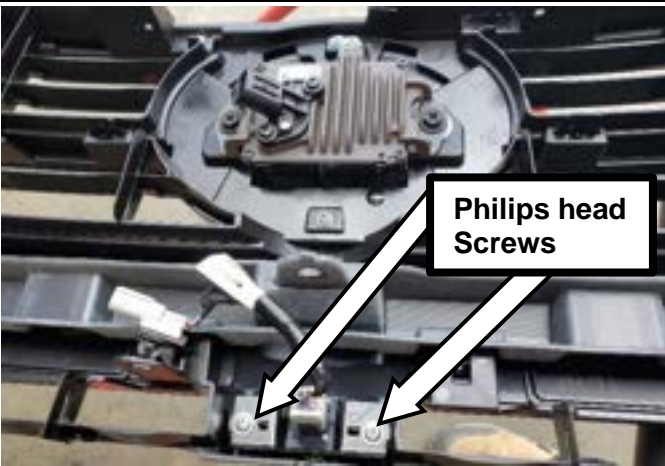

14. Remove the camera and camera bracket by removing the two Philips head screws connecting the bracket to the grille.



15. Remove plastic lower crush absorber from vehicle and discard.

Note: Lower crush absorber is retained by plastic clips. Levering absorber free with a large screw driver may aid removal.



16. Remove two M10 bolts on both sides (4 total) fixing crash beam to chassis and remove crash beam.

Discard crash beam.

Note: Retain four M10 bolts for reuse.

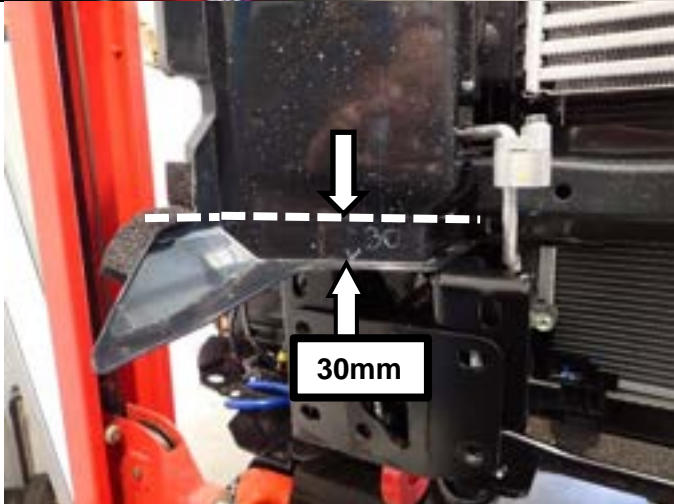

17. Locate air deflector panels and mark up 30mm from bottom edge as detailed in the image – (Right Hand side shown).

Use an oscillating multitool or shears to carefully cut lower portion away and discard.

Note: Take care not to damage any other components on the vehicle whilst cutting.

Carefully remove any burrs or sharp edges with a file and/or sandpaper.



(RHS SHOWN)





Connector access points

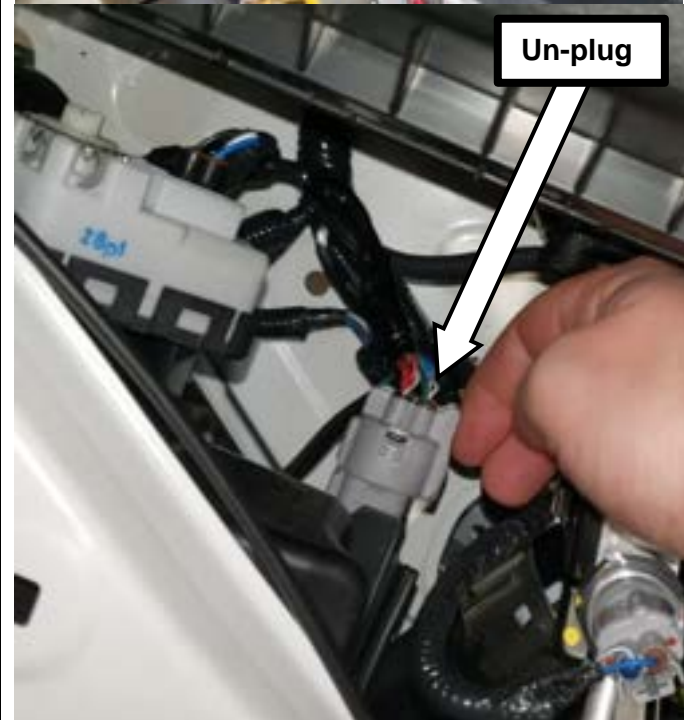

Un-plug

18. From the inside of the engine bay, unplug the grey OE connector from each headlight. Plug in the corresponding male/female connectors from the wiring loom 6821454 (provided in the kit) into the OE connectors.

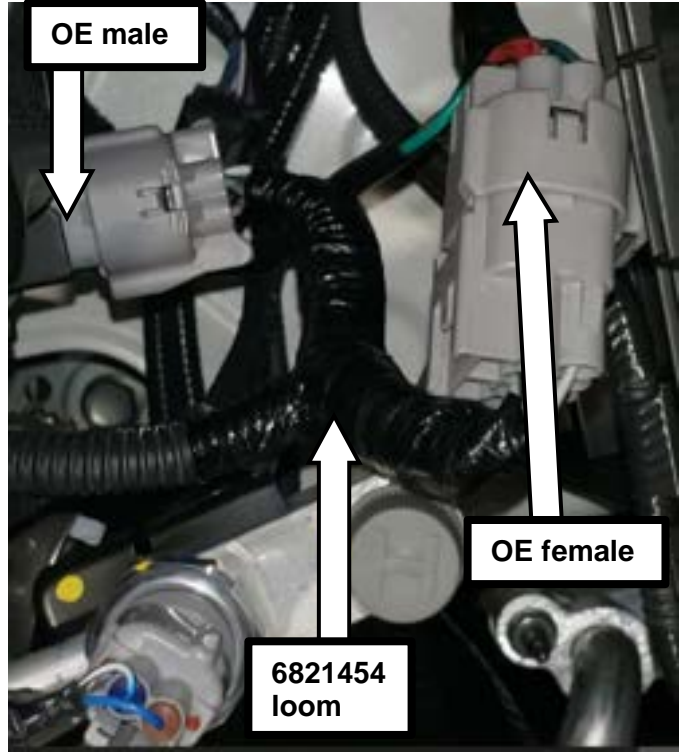

OE male

OE female

6821454 loom

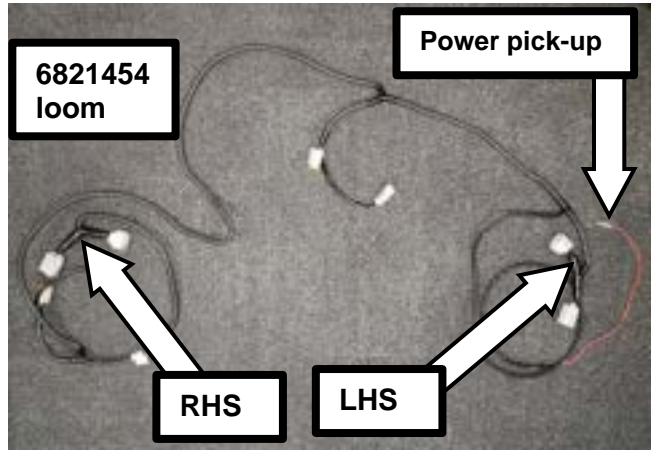

6821454 loom

Power pick-up

RHS

LHS

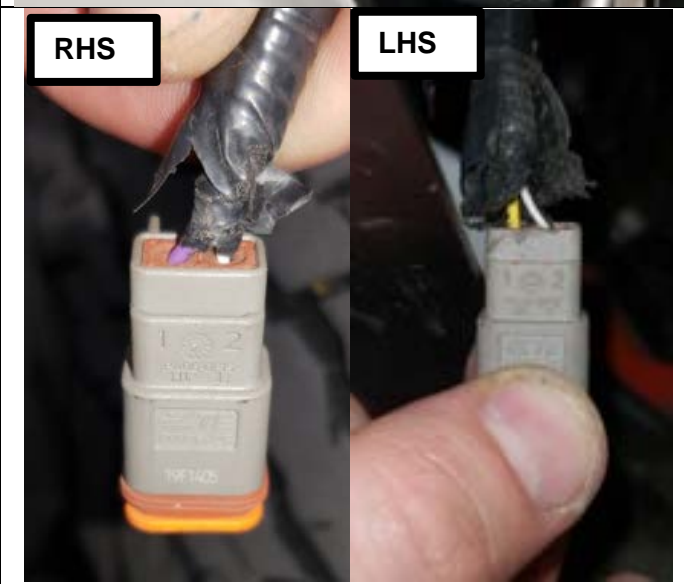

RHS

LHS

19. Locate the OEM fog light connectors on the vehicle. Cut off the lamp connectors, and fit the deutsch connectors as shown.

Use the following table for wiring;

Side	Deutsch Pin	Vehicle Wire Colour
RHS	1	Purple
RHS	2	White/Black
LHS	1	Yellow
LHS	2	White/Black

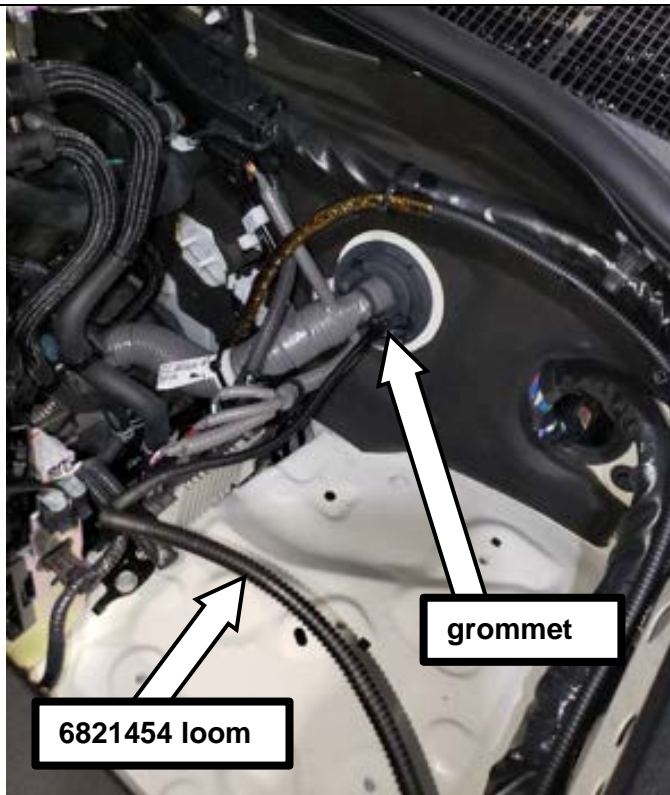

20. Located in the rear left hand side of the engine bay, cut the end of the grommet nipple, and feed the red power pick-up end of the 6821454 through the firewall.

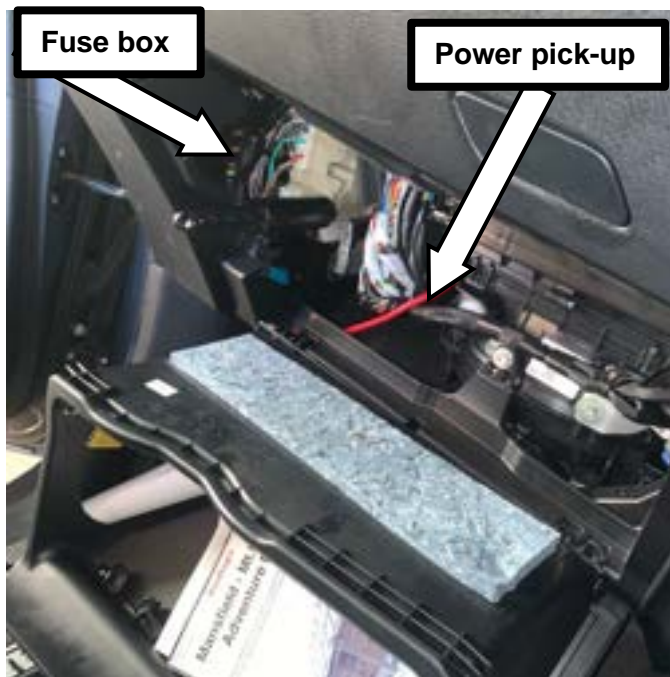

21. Drop the glove box in accordance with the vehicle manual to gain access to the fuse box located behind. Connect the fuse adapter to the end of the power pick-up end.

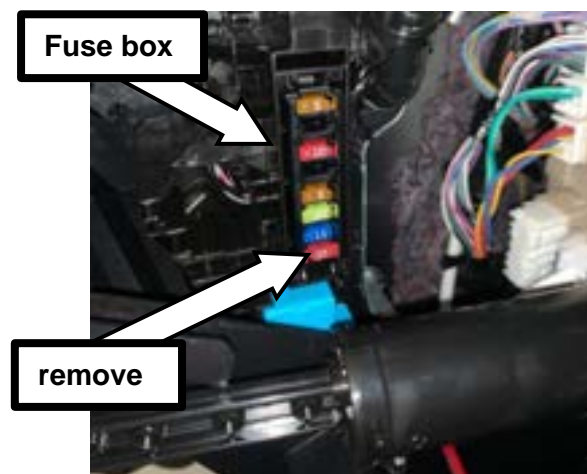
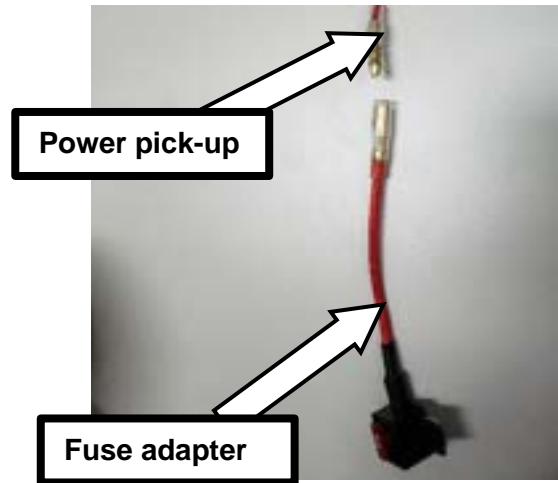

22. Remove the bottom fuse, install into adapter, and reinstall into original position.

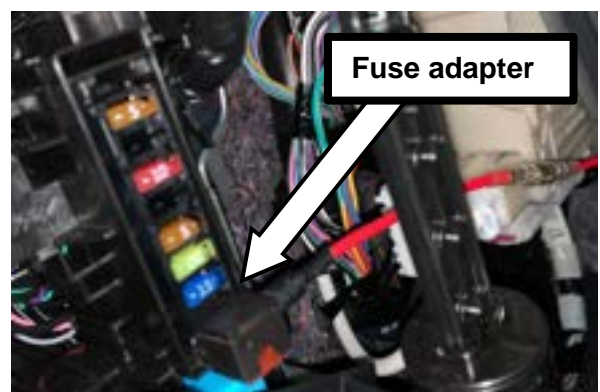

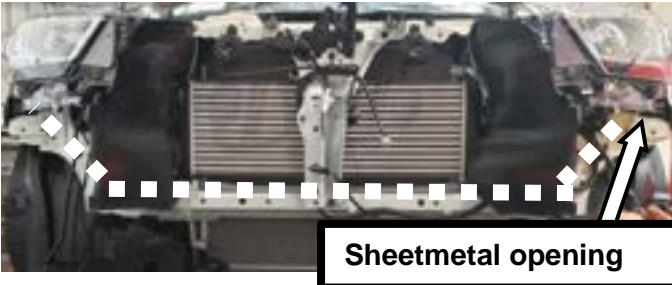
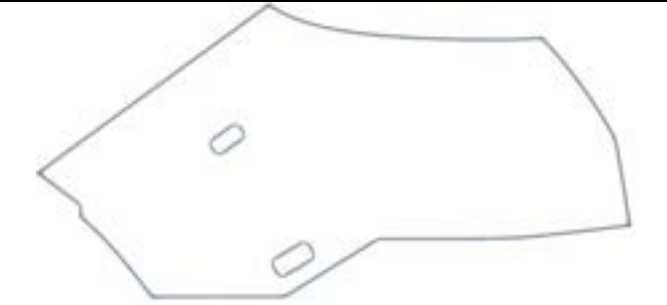
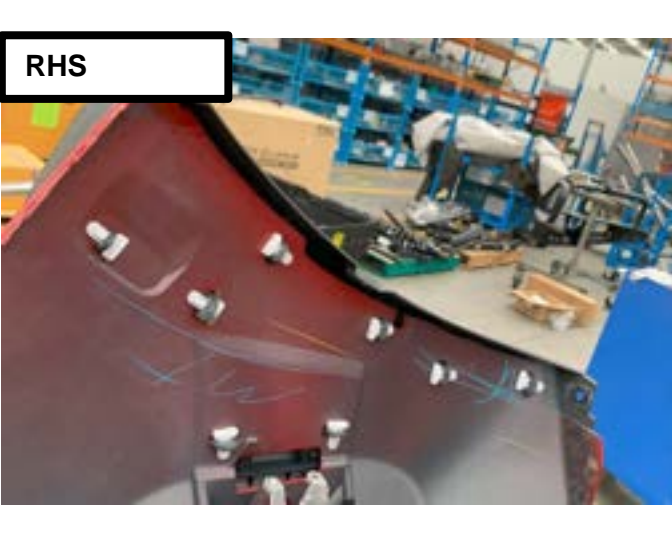
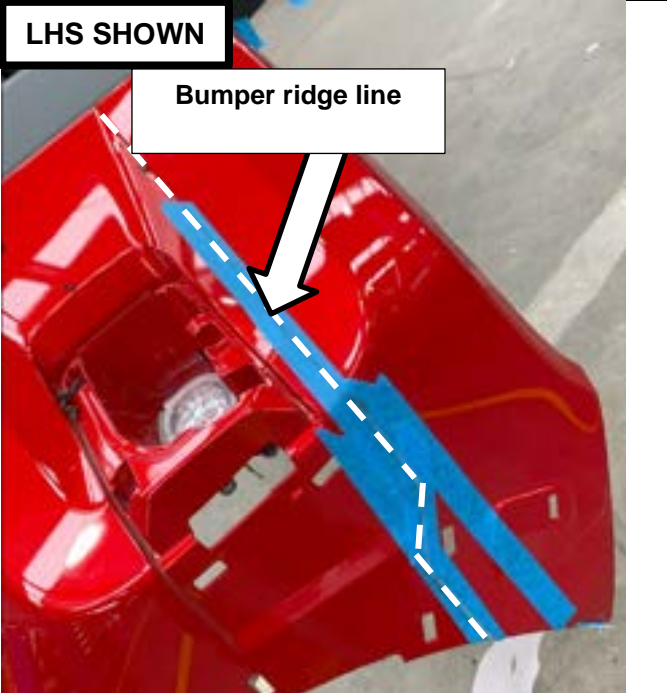
	<p>23. Trim the fuse box cover, and refit to fus box. Reinstall glovebox as per vehicle manual.</p>
	<p>24. Ensure wiring loom 6821454 is routed down through the opening in the sheetmetal behind the headlight, and across the air deflectors.</p>
	<p>25. Carefully cut out bumper cut template supplied.</p> <p>Note: Template will be used for both sides (LH & RH) – be careful not to damage.</p>
	<p>26. Remove flares from bumper by removing clips. Retain clips and flares.</p>
	<p>27. Stick masking tape onto bumper at area underneath headlight (as shown), running the tape in towards the centre of the bumper.</p> <p>Position template onto RHS of bumper aligning with edges of the bumper specified on the template.</p> <p>Using a permanent marker, outline edges of bumper cut template onto masking tape where the bumper cut will be performed.</p> <p>Remove template and repeat for LHS. Take care not to rip template upon removal.</p>

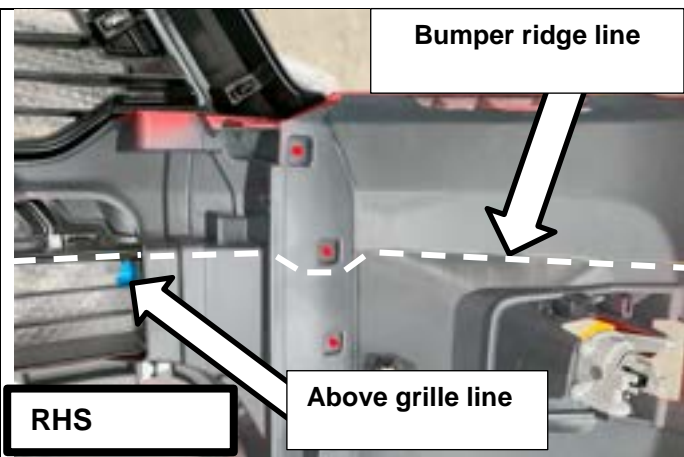

28. Identify the first horizontal line of the grille below the solid section. The grille will be trimmed immediately below this line.

Apply a generous amount of masking tape in the area indicated on the grille. Extend horizontal line to the outside edge of chrome/black border of the grille.

29. Final cut line should appear as shown below:

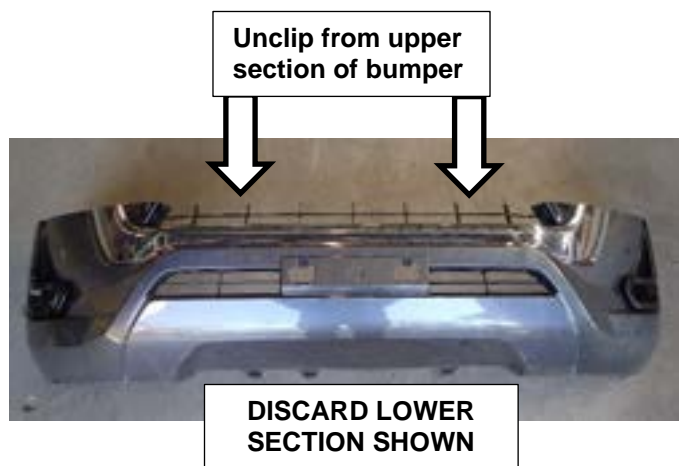

30. Carefully cut bumper along marked lines using an oscillating multitool or jig saw. Repeat for LHS.

Unclip lower grille section from upper bumper and grille.

Discard lower grille and bumper section, this will not be reused



Warning: Cutting operations can result in flying metal debris, safety glasses should be worn.



31. Install bumper and fasteners removed previously.

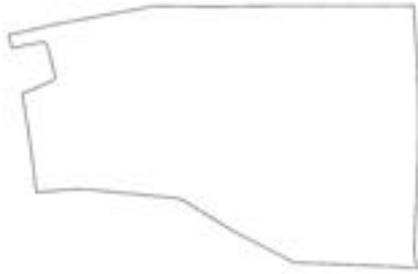

32. Carefully cut out flare cutting template supplied.

Note: Template will be used for both sides (LH & RH) – be careful not to damage.



Flare foglight housing

33. Apply masking tape to the area of the flare above the flare foglight housing (as shown). Position template onto RHS of flare, aligning with edges of the flare specified on the template.

Using a permanent marker, outline edges of template onto masking tape where the cut will be performed.

Remove template and repeat for LHS. Take care not to rip template upon removal. Cut the flare using a jigsaw or multitool.



Warning: Cutting operations can result in flying metal debris, safety glasses should be worn.



34. The 300mm strip of double sided tape into six smaller strips.

Use alcohol wipe to clean the both sides of the mating flares (removed with bumper and remaining on front quarter panel). Repeat on opposite side.

Apply adhesive primer stick to cleaned surfaces. Repeat on opposite side.

Attach the flares together, ensure the flare kes

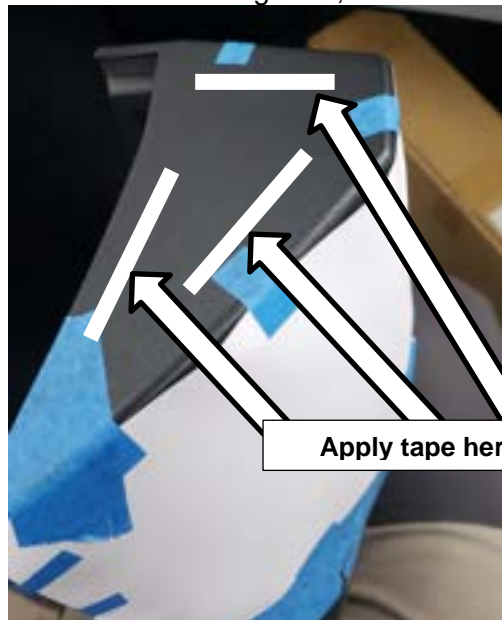

Apply tape here

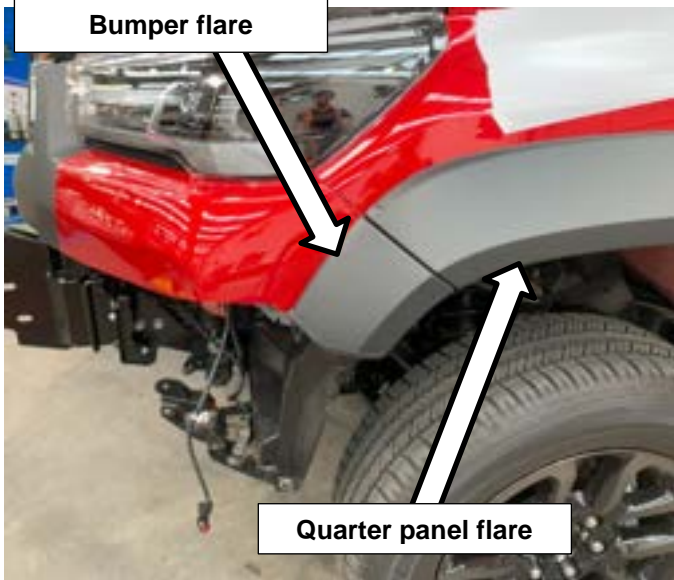

35. Re-install flares, ensure tape sticks to both flares (bumper and quarter panel). Drill a Ø4mm hole through both flares. Repeat on opposite side.

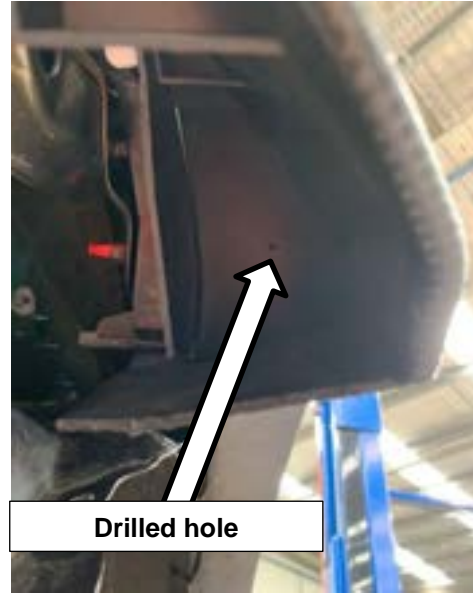

36. Using a screw removed in step 6, fasten flare sections together.

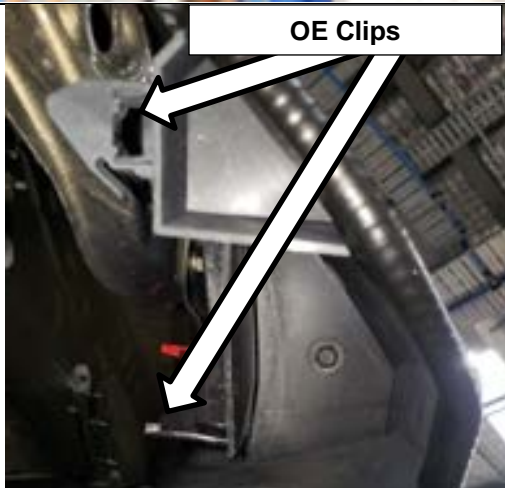

37. Install OE flare clips (3 per side) removed previously to connect flares to bumper. Repeat on opposite side.



38. Reconnect radar.



39. Fit pinch weld to RH side flare, along the full length of the cut edge. Carefully trim off any excess length and use remainder for other side.

Note: 1 full length of pinch weld supplied, ½ used on each side of vehicle.



If required required, relieve pinch weld to facilitate fitment.

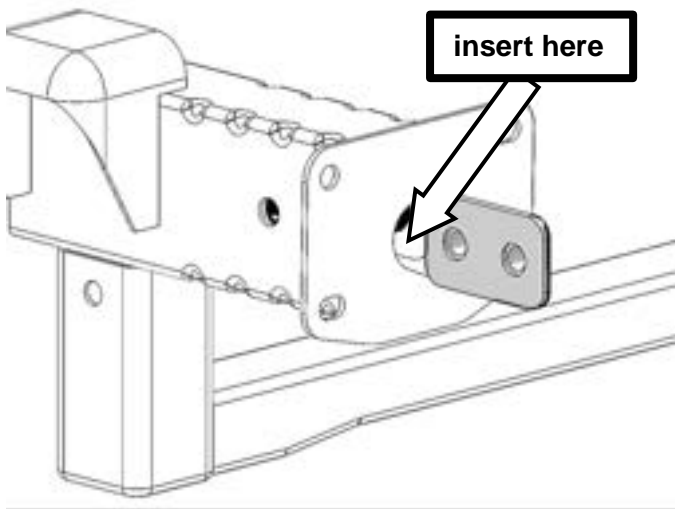

40. Insert two M12x1.75 nut plates into RHS chassis rail as shown.

Note: 1 x nut plate is used to fasten the outer chassis support to the outside face of the chassis and 1 x nut plate is to fasten the inner chassis support to the inner face of the chassis. Install nut plates accordingly.

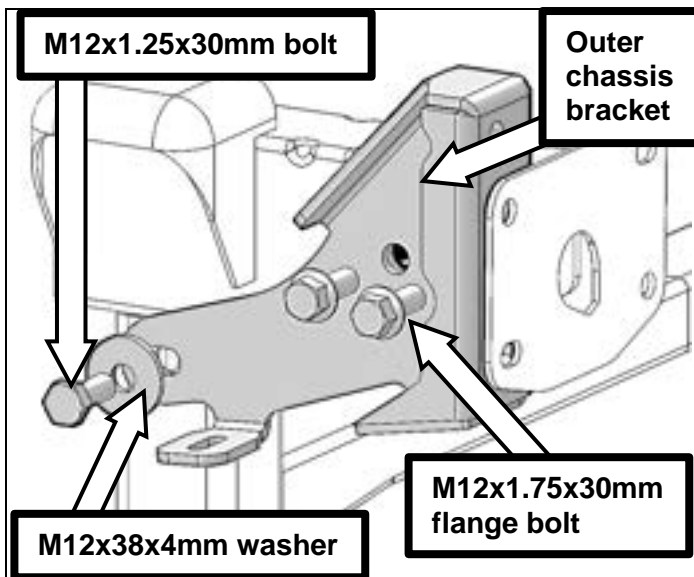

41. Loosely fasten RHS outer chassis support bracket to outside face of chassis using two M12x1.75x30mm flange bolts installed into the previously installed nut plate.

Loosely fasten the RHS outer chassis support bracket at the rear hole using one M12x1.25x30 bolt and M12x38x4mm flat washer installed into OE captive nut in the chassis bracing.

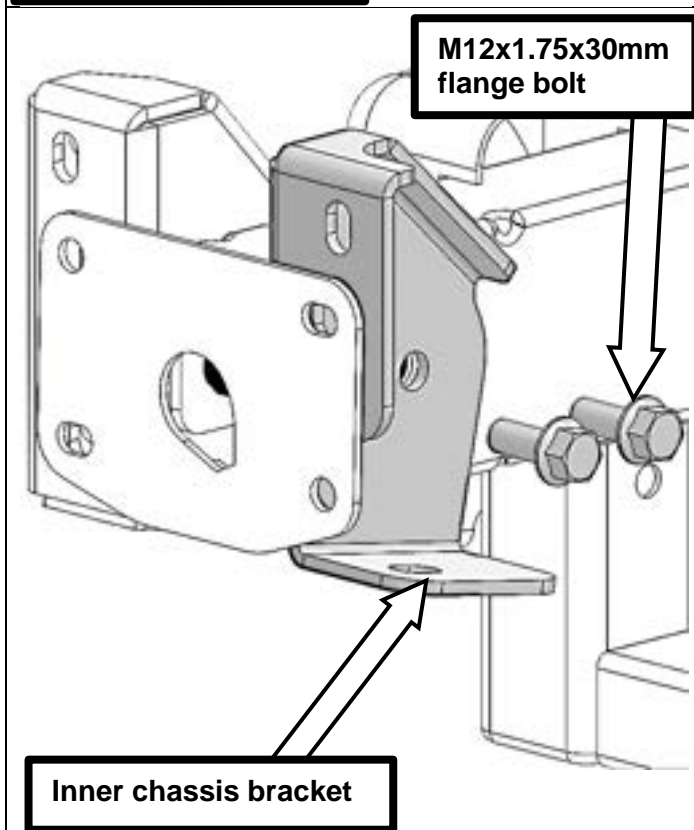

42. Loosely fasten RHS inner chassis support bracket to inside chassis face using two M12x1.75x30mm flange bolts installed through the holes into the previously installed nut plate.

Repeat process to install chassis support brackets on LHS

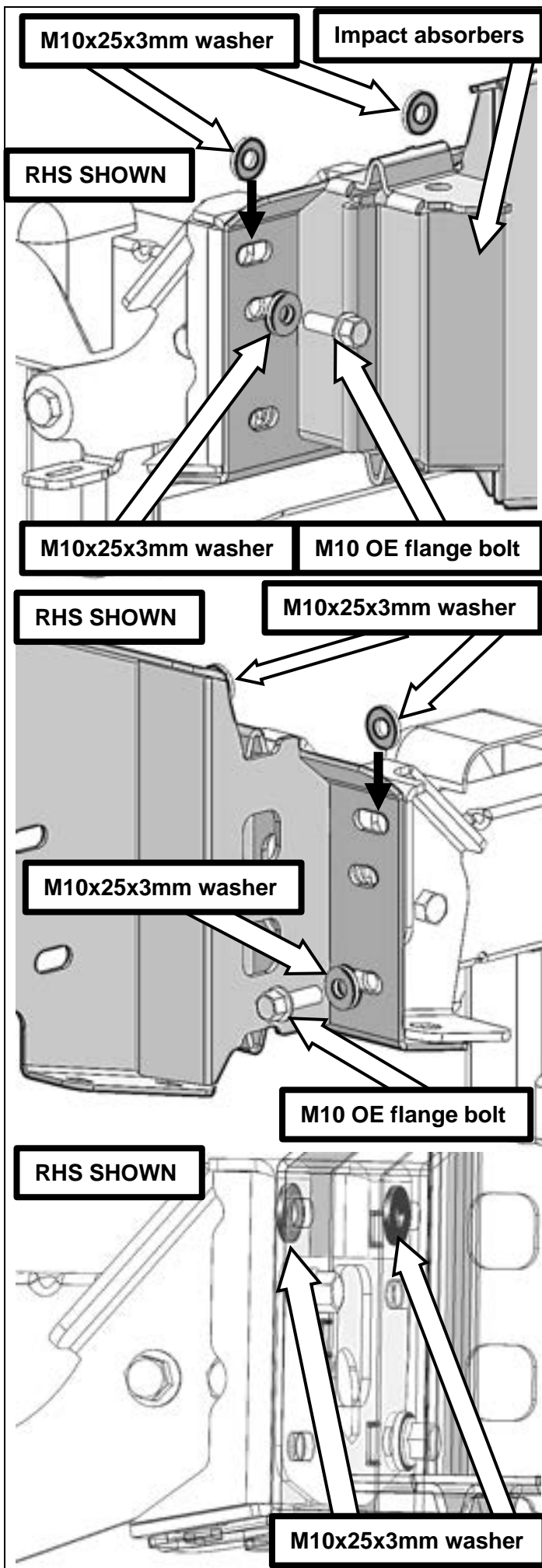

43. Loosely install the bull bar impact absorbers onto vehicle chassis flange by fastening two OE M10 flange bolts (retained in step 16) and two M10x25x3mm flat washers into the chassis flange captive nuts.

IMPORTANT

Ensure two M10x25x3mm flat washers are installed inline with the top impact absorber slots, between the impact absorbers and rear chassis support brackets.

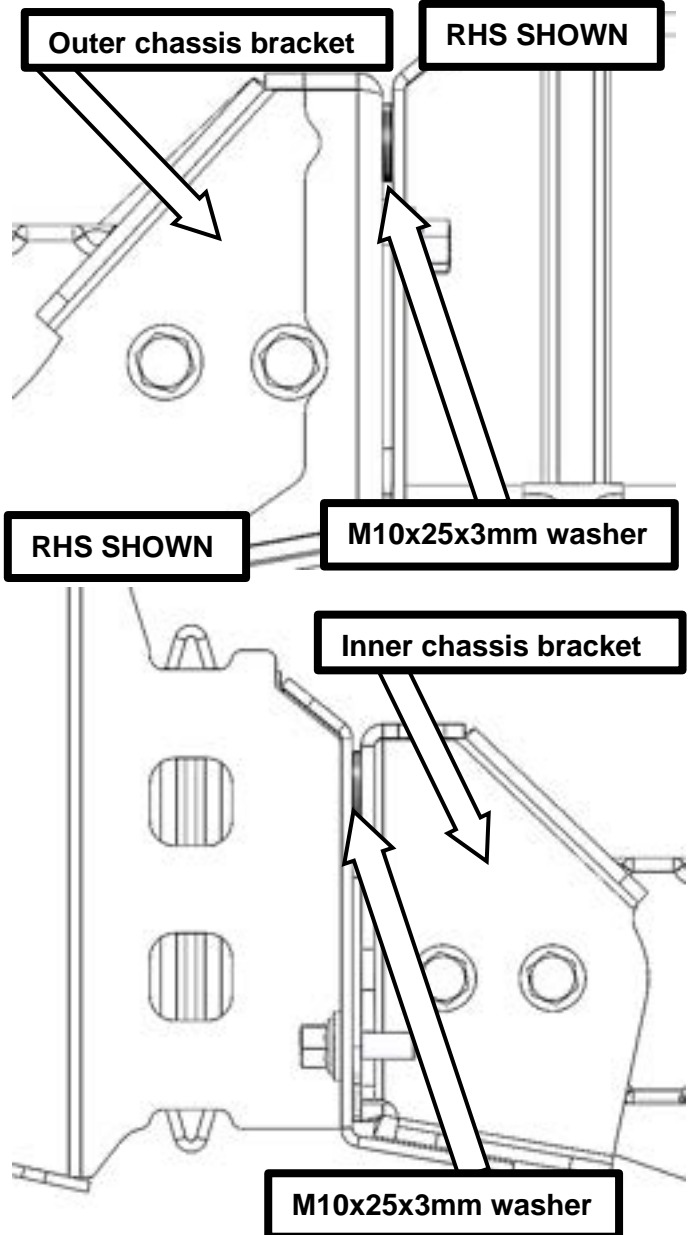

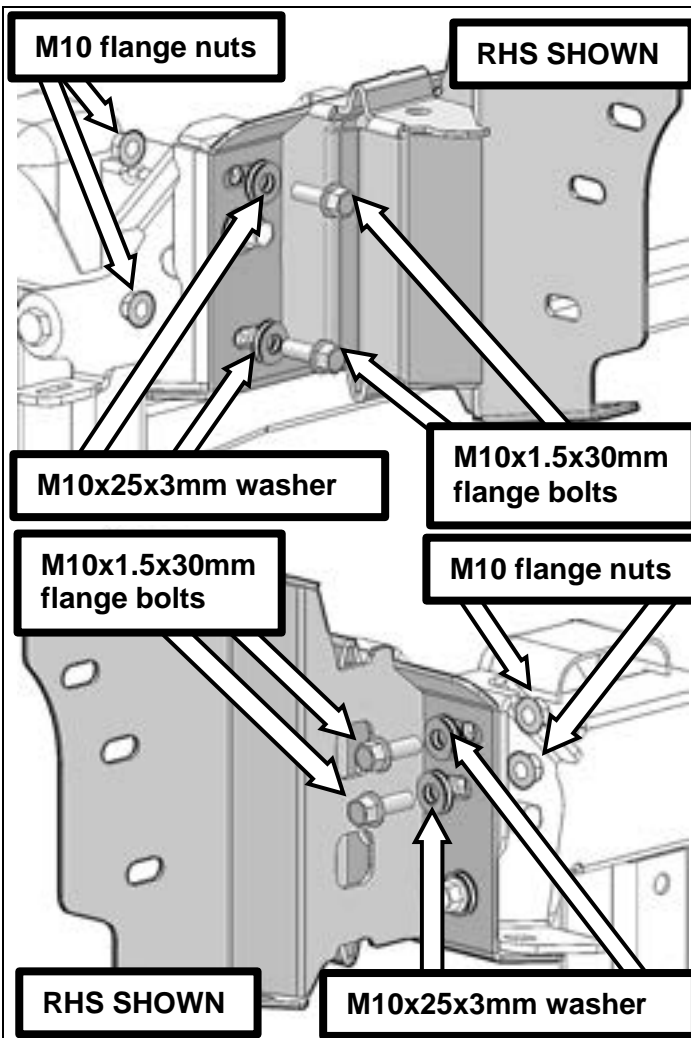

44. Loosely fasten four M10x1.5x30mm flange bolts, M10x25x3mm flat washers, M10 flange nuts through bull bar impact absorbers, chassis flange and rear chassis support brackets.

NOTE: IMPACT ABSORBERS ARE HANDED. RIPPLES ARE ON THE OUTSIDE OF MOUNTS

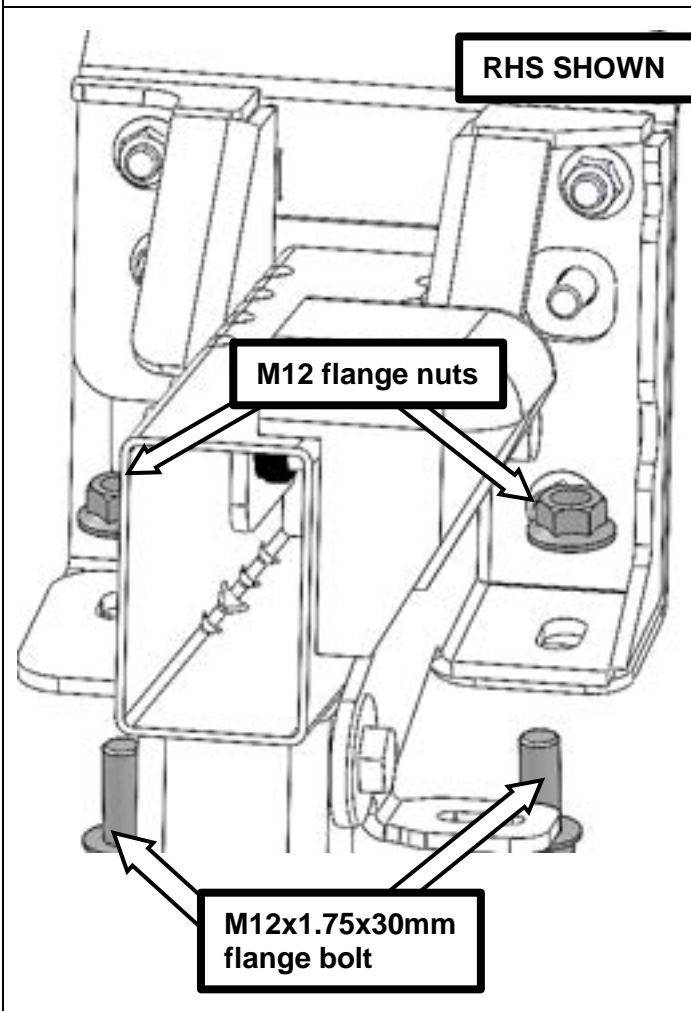
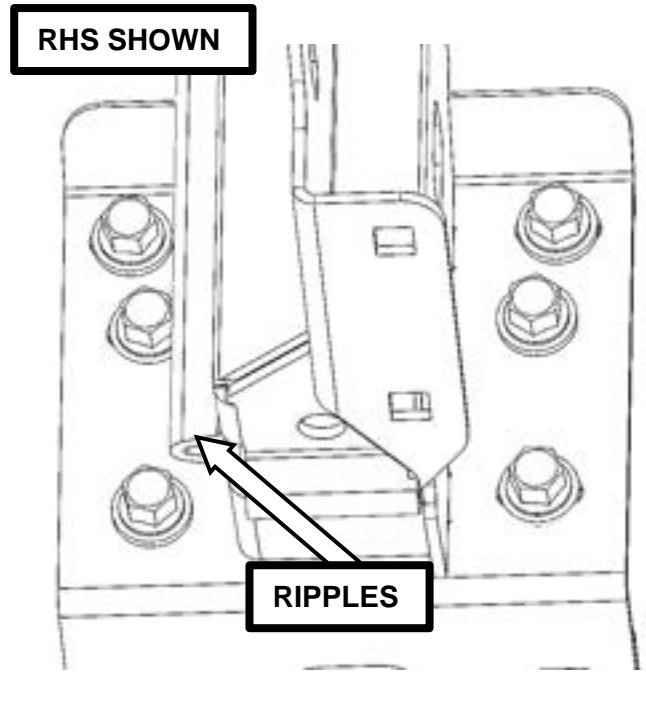

45. Loosely install two M12x30 flange bolts through lower slot of the impact absorbers and chassis support brackets into M12 flange nuts.

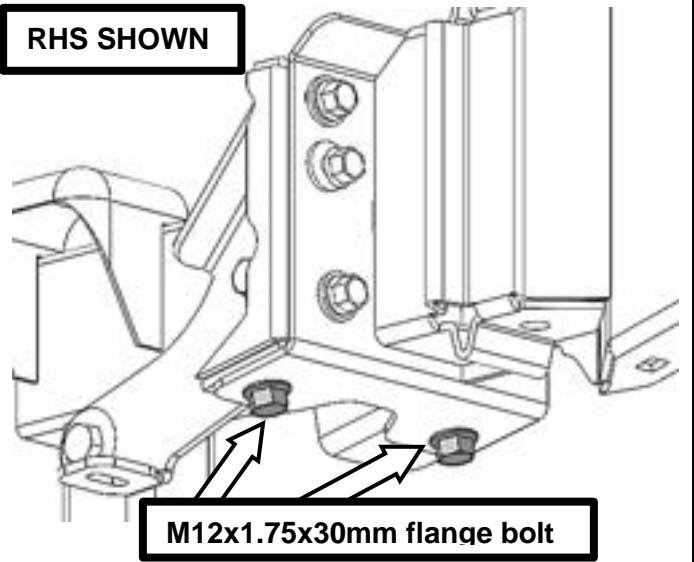

Repeat process to install impact absorbers on the LHS.

Note: Starting with the M10 bolts installed from the front of the impact absorber, tighten all fasteners enough to eliminate any play in mount or support brackets but to still allow for adjustment of bull bar.

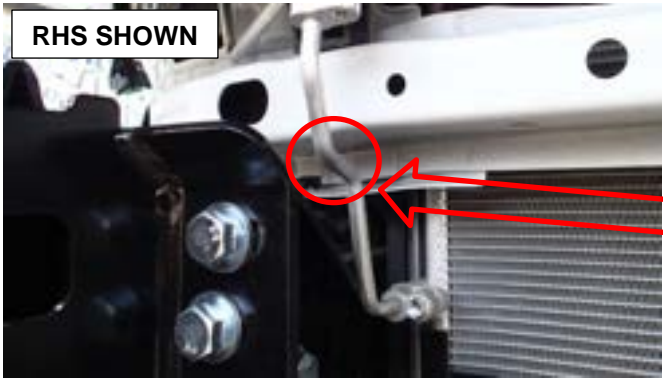

RHS SHOWN

46. Check clearance between mount and AC line is approximately 15mm.

NOTE:

If necessary the AC tube can be carefully bent away from the bracket by pushing the top section towards the vehicle. While bending the tube. Make sure you support the lower fittings to avoid damage.

Note: If fitting a winch proceed from here using fitting instructions 37801131 supplied with 3501130 bull bar winch install kit.

47. Run a strip of masking tape across the grille (as shown) and mark the following dimensions. Carefully cut grille along marked lines using an oscillating multitool or jig saw. Unclip lower grille section and discard

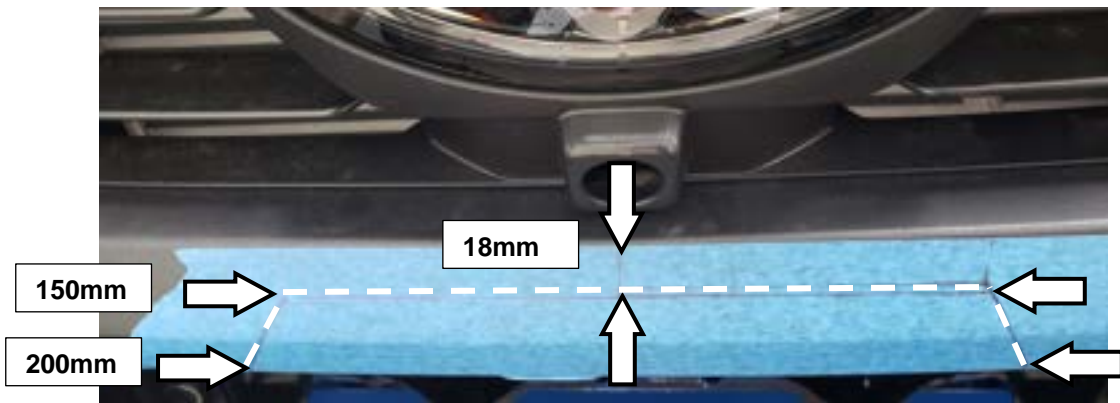

Once the winch is fitted, please continue to step 49. If no winch is being fitted, continue from here.

48. Slide the winch cover panel from the bottom up until it is level with the top face of the bar.

Fit the winch cover panel to the bar using 4 x M6 x 20 hex bolts, flat washers and nyloc nuts.

Warning: Be careful not to scratch the finish of the winch cover panel.

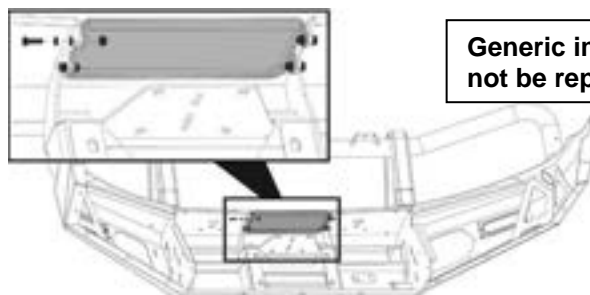

Generic image. Bull Bar shown may not be representative of actual product.



49. When relocating the front camera, separate steel bracket from back of camera by removing two Philips head screws and depressing shroud clips. Retain screws and discard bracket.



50. Mount the camera into the ARB relocation bracket using the two philips head screws removed in the previous step.

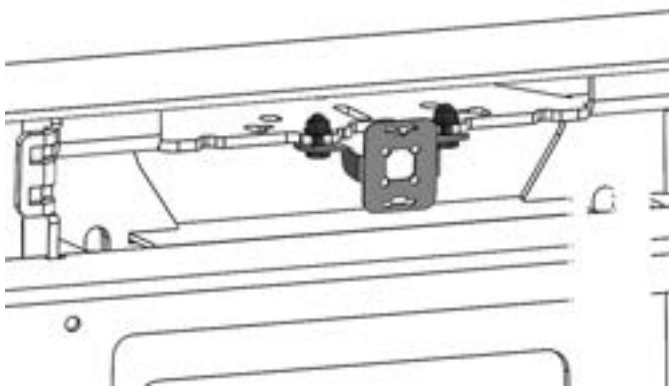

51. Install the camera to the winch cradle as shown using two M6x16 bolts, washers and flange nuts.
Note: camera not shown in image

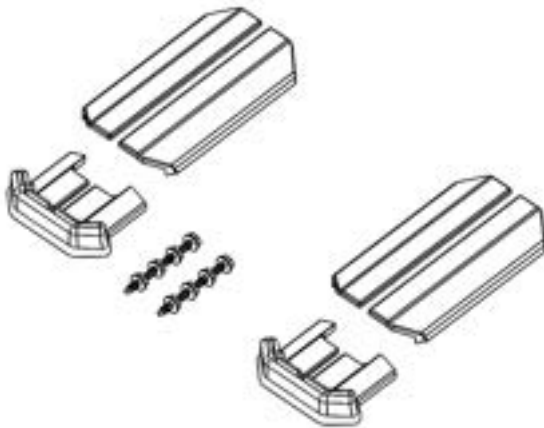

52. Identify the cover strap plastics kit, 3163294.

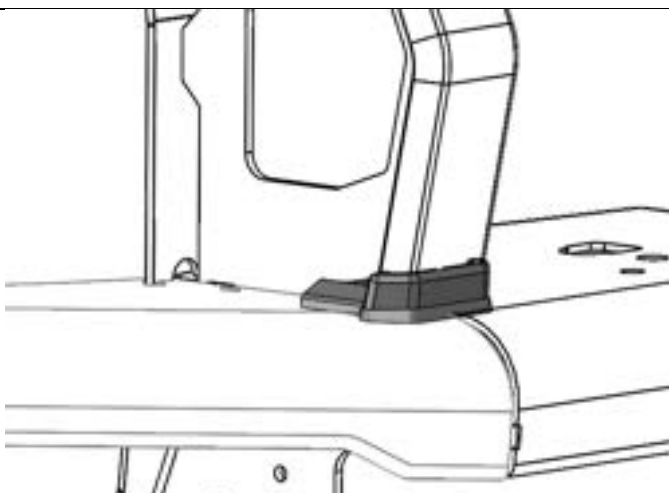

53. Fit the rubber intersection mouldings to the base of each upright cover strap.

Ensure that the skirt of the rubber moulding is not folded back on itself and is sitting flat against the bull bar.

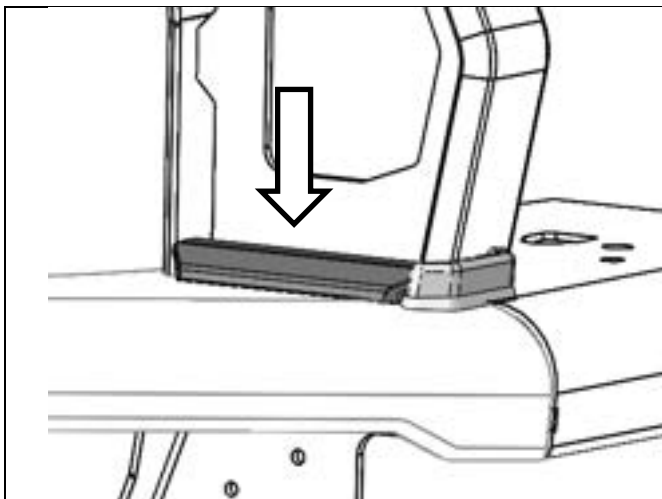

54. Place the plastic cover down onto the rubber moulding, repeat on both sides of the cover straps.

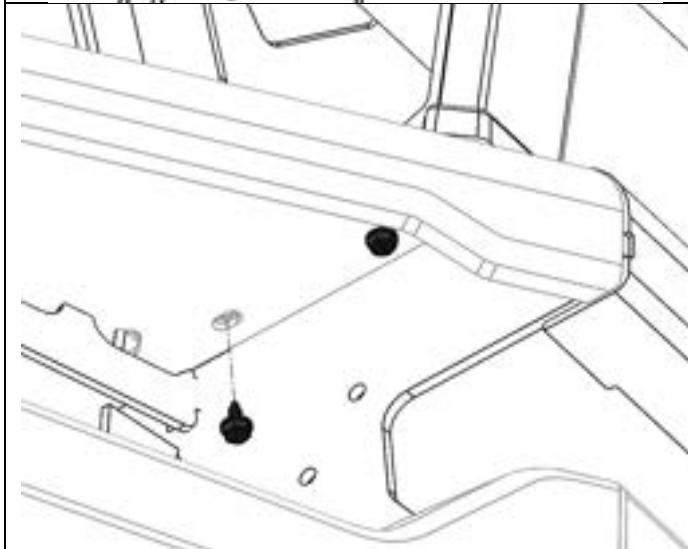

55. From underneath, fit two screws into each plastic cover. Tighten until the covers are secure and have firmly clamped the rubber moulding.

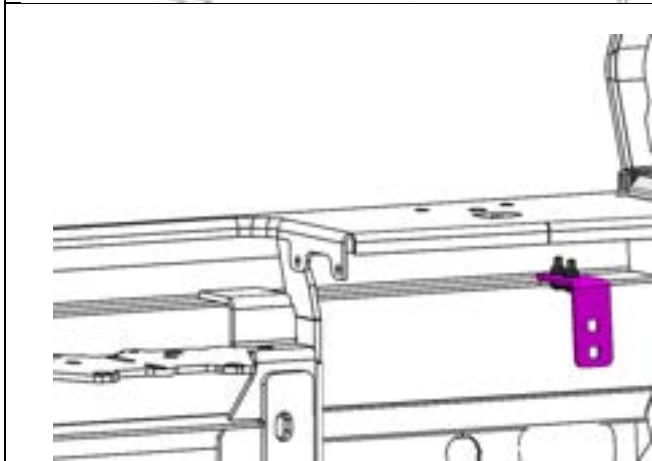
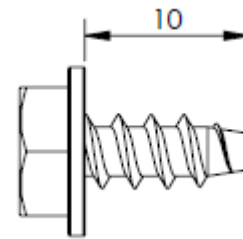

56. Assemble both grille retaining brackets onto the inside of the upper pan with M6x20 pan head screw, 12mm washer and flange nut. Torque to specification.

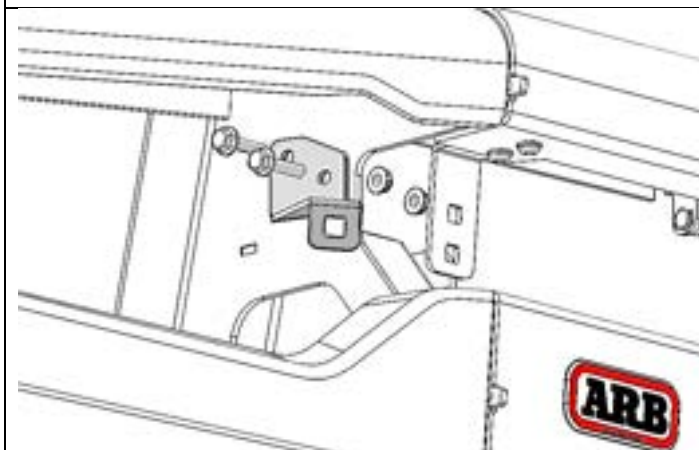
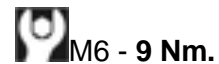

57. Assemble both fog cluster mounting brackets onto the outside of the uprights with M6 flange bolts and flange nuts. Torque to specification.



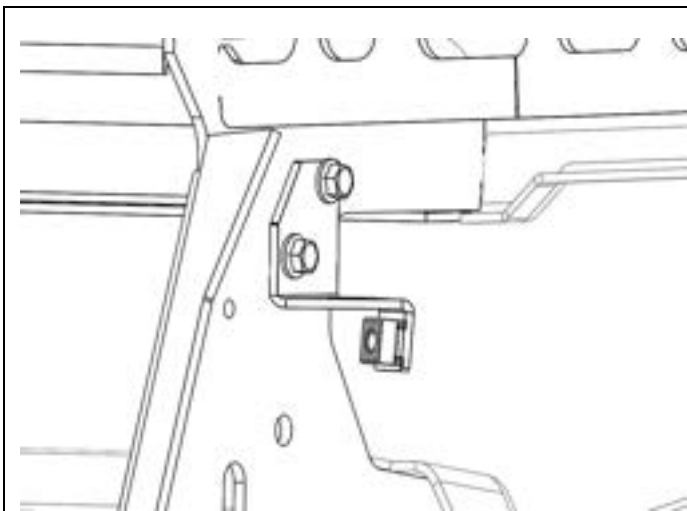

58. Assemble silver M6 cage nuts into both fog cluster mounting brackets.

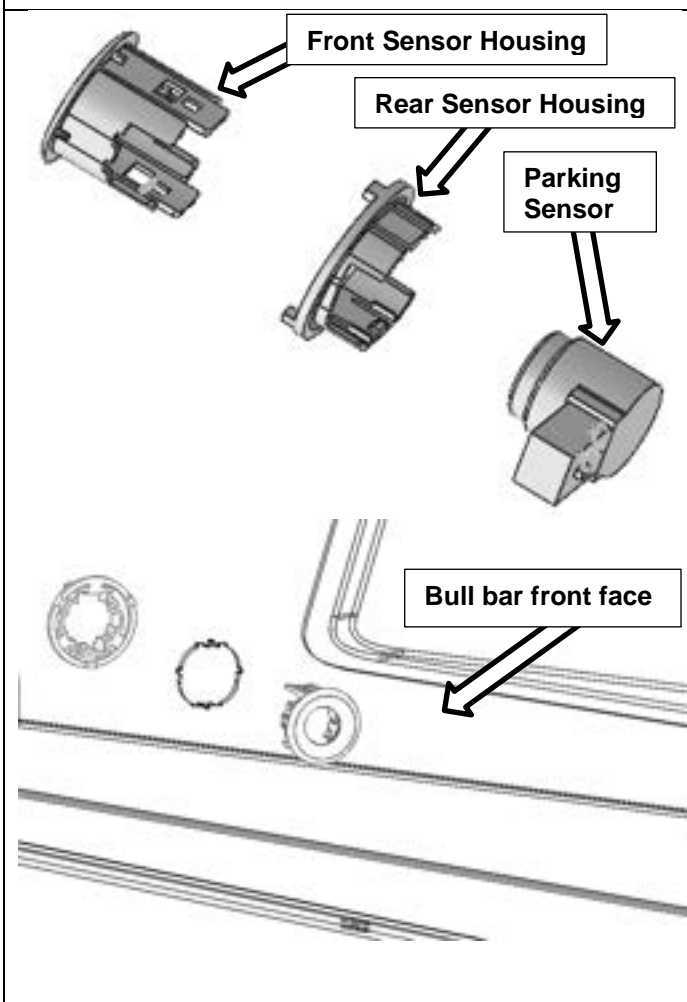

59. Fit the front sensor housing from the front of the bull bar into the designated aperture.

Fit the rear sensor housing to the rear side of the bull bar.

Note: Ensure the two pieces engage correctly and are secure.

Fit the parking sensor into the sensor housing. Ensure the tails of the sensors are in the same orientation as found in the bumper.



Fitment of bull bar to vehicle

60. With the assistance of another person, place the bar on the vehicle mount brackets.

WARNING: Due to the weight of the bar and winch if fitted, it is advised that you use some form of mechanical assistance when lifting the bar onto the vehicle such as an elevating trolley.

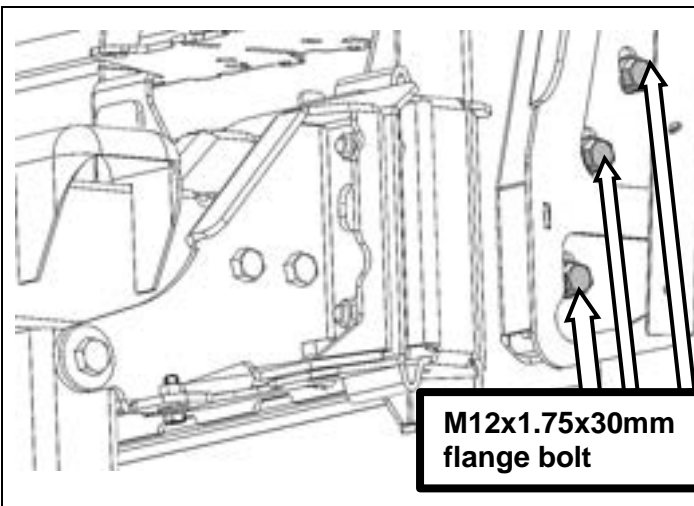

61. With the bull bar sitting in place, fit three black M12x1.75x30 flange head bolts and M12 flange nuts per side. Leave finger tight for now.



62. Check the clearance of the bar to the vehicle, and adjust position of bar left/right until it's sitting central to body, then tighten all fasteners joining mount assembly to chassis brackets (four M10 ARB and two M10 OE bolts each side).

 M10 – 44Nm

Tighten all inner and outer M12 chassis support bracket fasteners.

 M12 – 77Nm

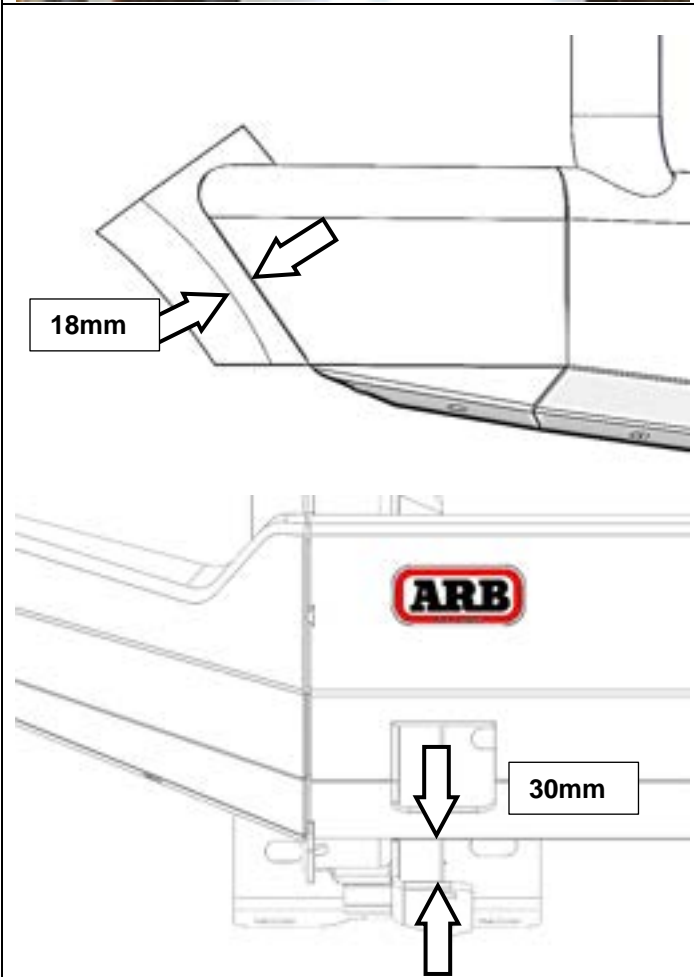

63. Once position has been confirmed, adjust bull bar on mounting slots to achieve an 18mm gap between wings and flares. In addition, check that the bar is level by measuring the distance from the impact absorbers to the lower section of the bar on both sides.

Torque M12 mounting bolts to specification.

 M12 - 77 Nm.

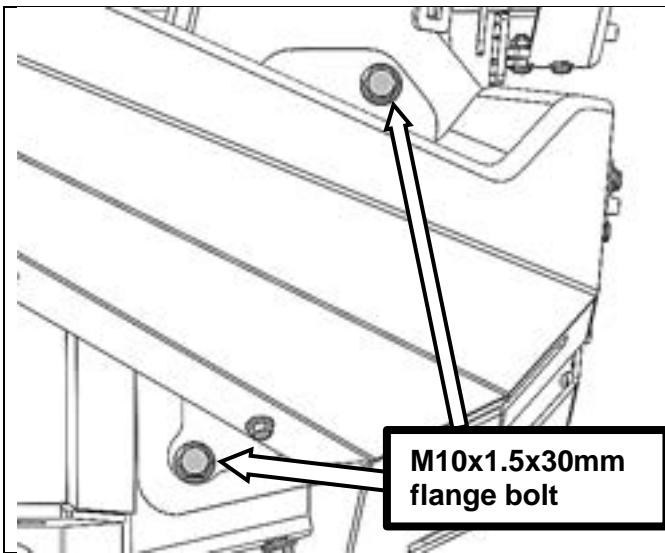

64. Drill 4 x Ø10mm holes (2 per side) through mount assembly using existing holes in bull bar as guide. This may require a right-angled drill.



Add anti-corrosion touch up paint to areas drilled, then assemble and tension four M10x30 flange bolts and flange nuts to specification.

 M10 - 44 Nm.

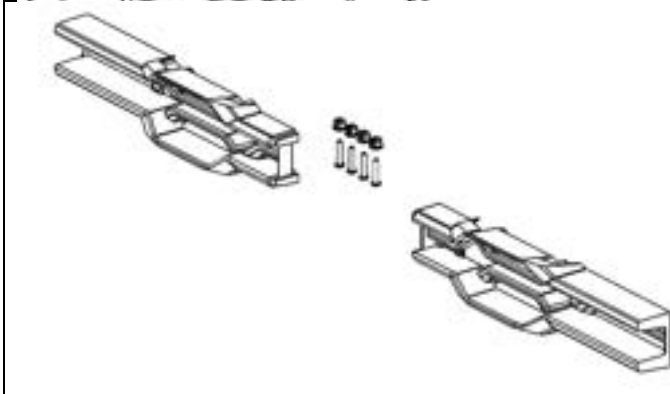

65. Identify the outer grille section kit, 3163295.

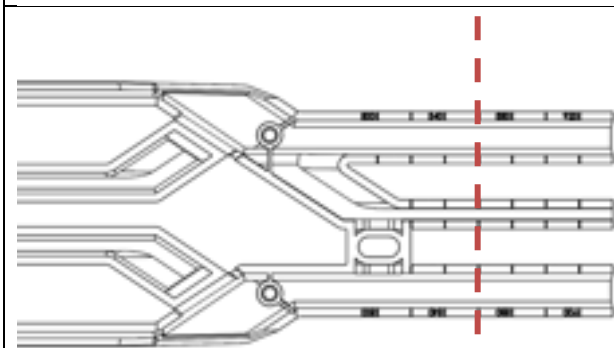

66. Mark both grille panels to be cut at the 860mm markings on the back face.

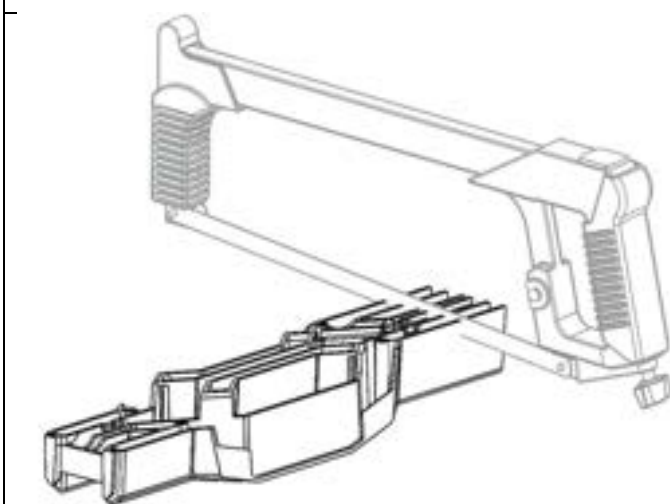

67. Use a hacksaw or similar cutting tool to carefully cut the grille panel at the positions marked in the step above.

Discard the off cuts and clean up the cut edges using a file or sandpaper.

BEFORE

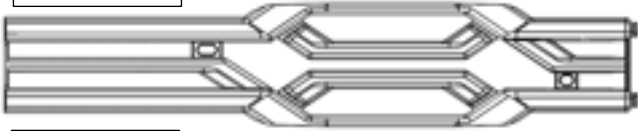

AFTER

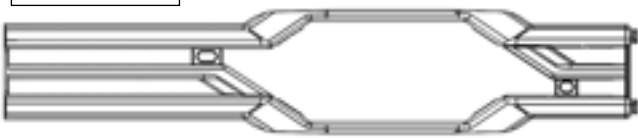

68. If fitting a winch, remove grille sections shown for access to clutch lever.

Cut from rear with an oscillating multi-tool.



Top

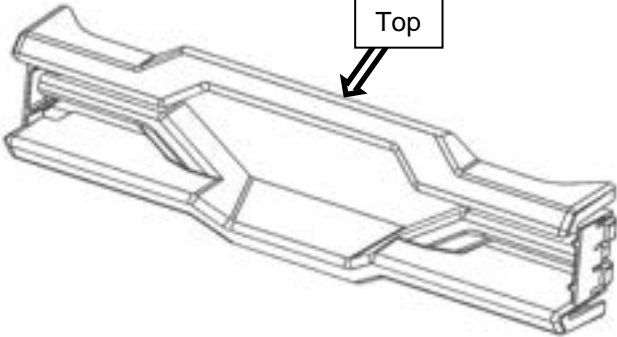

69. Identify the inner grille section kit, 3163289.

Note: the orientation of the grille centre.

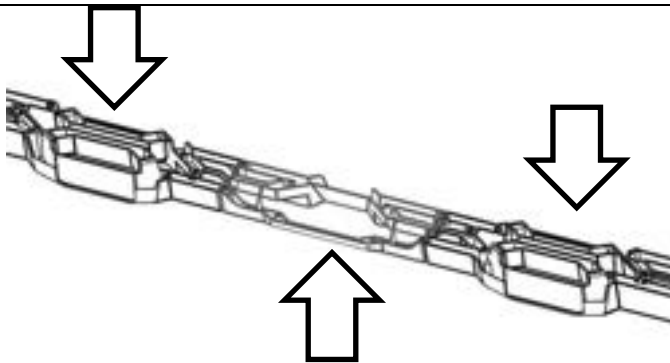

70. Assemble centre section into both outer sections, make sure clips are fully engaged.

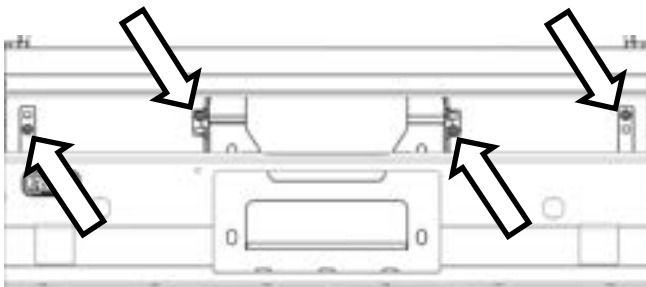

71. Press four round plastic grommets from grille kit into the square cut-outs seen from the front of the bull bar.

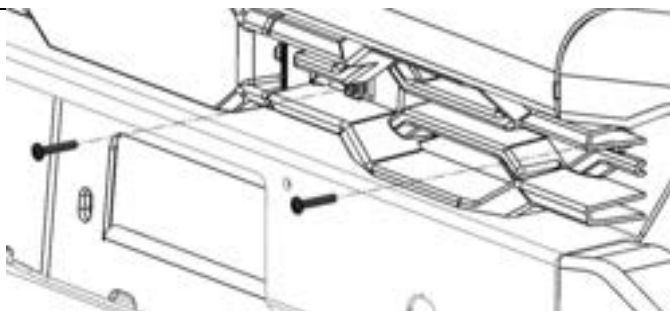

72. Attach grille assembly to bull bar using four torx head screws supplied in grille kit.



73. Camera should sit in the grille as shown.

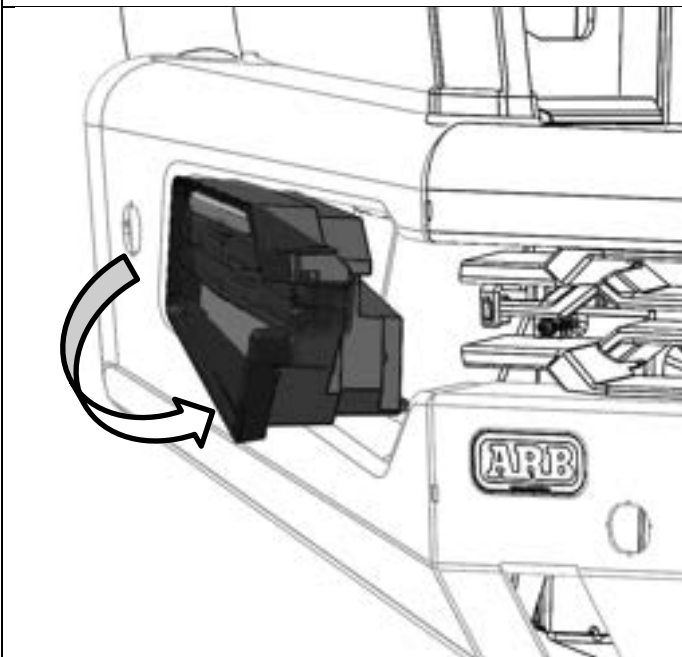

74. Index the outside groove of the lamp cluster over the edge of the aperture in the bull bar wing. Then rotate the lamp cluster into place.

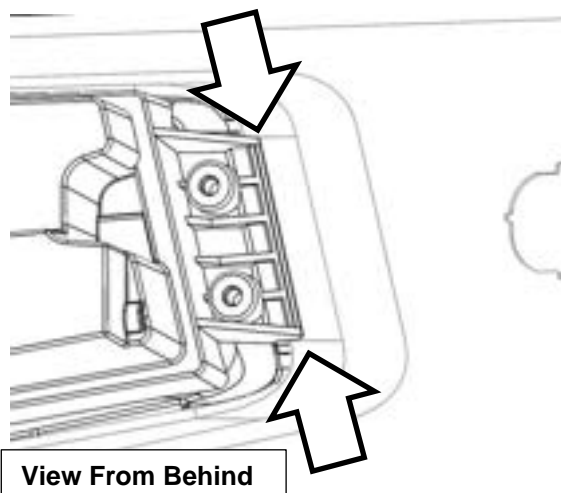

75. Secure lamp cluster with M6 torx head screw.

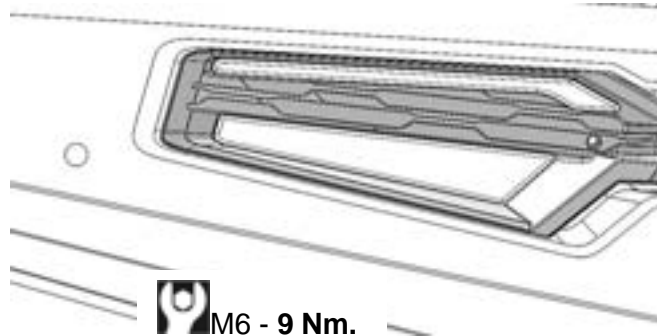
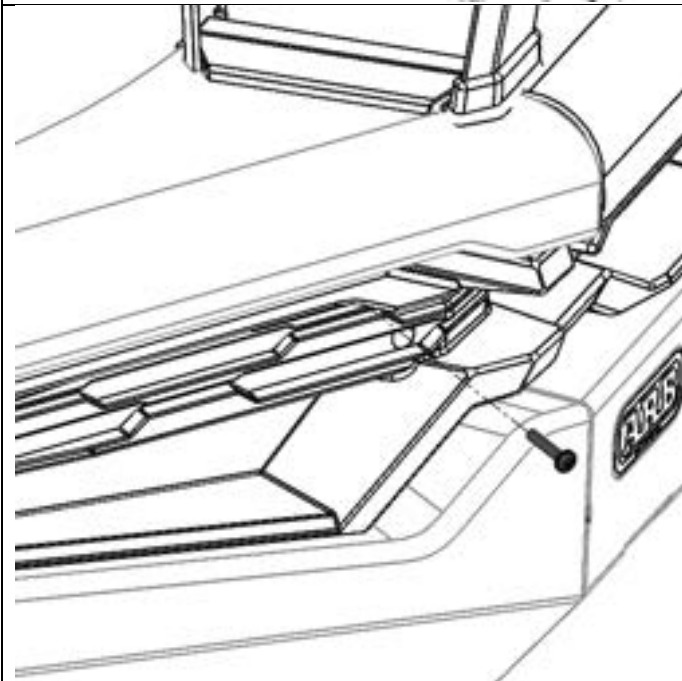

Connect lighting harness into the back of each fog cluster.

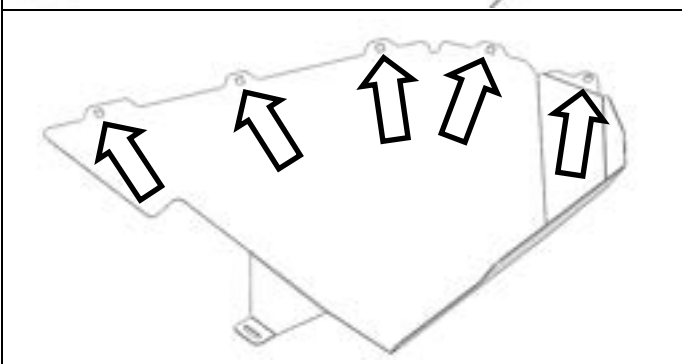

76. Fit five M6 cage nuts to each wing under panel.

Note: Cage nut heads to be located on top side.

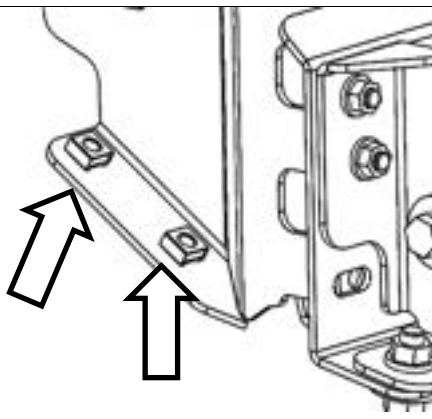

77. Fit four M8 cage nuts to RH and LH bull bar impact absorbers as indicated. (RH Mount Shown)

Note: Cage nut heads to be located on top side of mount assembly.



78. Temporarily place the wing under panel in position, and mark lines onto the OEM inner guards (LH & RH) using lower edge of wing under panels as guide ensuring enough guard remains so that it may be neatly tucked/secured behind wing under panel lip.

Caution: Use care not to damage the windscreen washer bottle or hoses when trimming LH inner guard.

Carefully cut along marked lines using jig-saw or shears.



Warning: Drilling operations can result in flying metal debris, safety glasses should be worn.

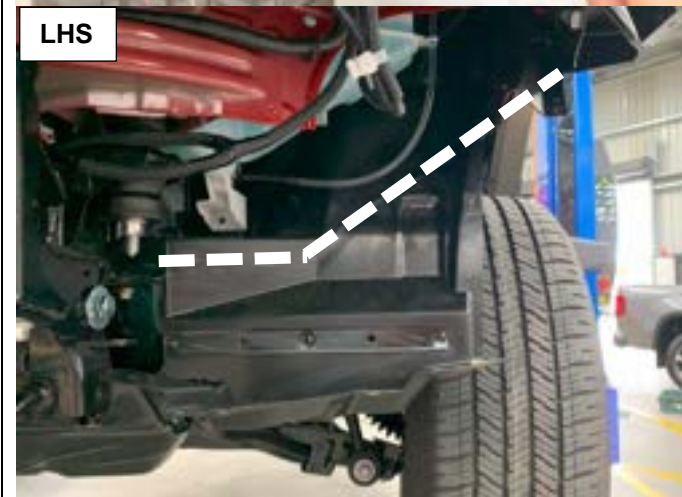

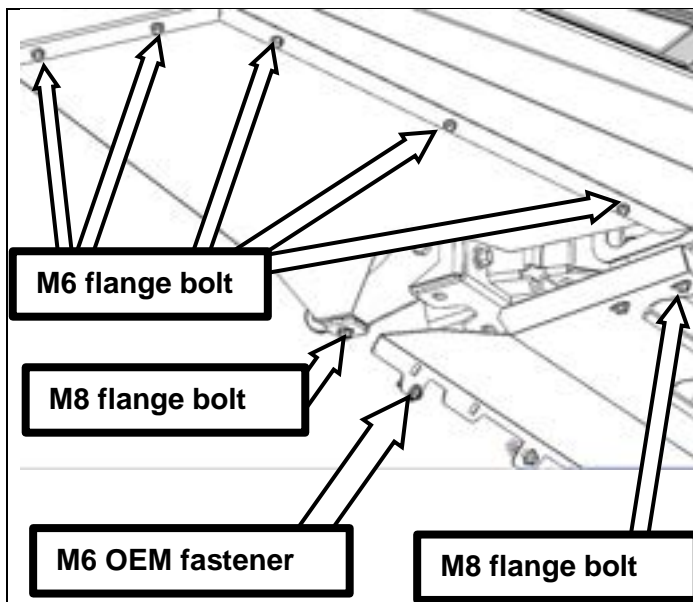

79. Fasten stone tray using five M8 flange bolts and two M6 OEM fasteners.

Fasten wing under panels to bull bar using seven M6 flange bolts.

Fasten lower corner of wing under panel using two M8x1.25x20mm flange bolts and M8 flange nuts

 M6 – 9Nm  M8 – 22Nm



80. Reach down from behind the grille to reconnect the camera.



81. Reinstall upper radiator cover panel and fasten using eight OEM scrivenets.

FITTED PRODUCT – TOYOTA HILUX SUMMIT MKII

NOTICE: ONCE SUMMIT BAR IS FITTED:

- ◆ Ensure all bolts are tensioned correctly.
- ◆ All wiring is clear of sharp edges or moving surfaces and secured properly.
- ◆ Piping is secured well away from sharp or moving components.
- ◆ Check operation of winch, if fitted.
- ◆ Check all wiring and connections to turn signal lamps and clearance lights and that they are functioning correctly.

