

NISSAN GU PATROL WINCH BULL BAR.

(SRS AIR BAG EQUIPPED MODELS)

PRODUCT NUMBER 3417100 / 3417110

WARNING

FOR VEHICLES EQUIPPED WITH SRS AIRBAG
WHEN INSTALLED IN ACCORDANCE WITH THESE INSTRUCTIONS, THE FRONT PROTECTION BAR DOES NOT AFFECT OPERATION OF THE SRS AIRBAG.

TAKE NOTE OF THE FOLLOWING:

- **THIS PRODUCT MUST BE INSTALLED EXACTLY AS PER THESE INSTRUCTIONS USING ONLY THE HARDWARE SUPPLIED.**
- **IN THE EVENT OF DAMAGE TO ANY BULL BAR COMPONENT, CONTACT YOUR NEAREST AUTHORISED ARB STOCKIST. REPAIRS OR MODIFICATIONS TO THE IMPACT ABSORPTION SYSTEM MUST NOT BE ATTEMPTED.**
- **DO NOT USE THIS PRODUCT FOR ANY VEHICLE MAKE OR MODEL, OTHER THAN THOSE SPECIFIED BY ARB.**
- **DO NOT REMOVE LABELS FROM THIS BULL BAR.**
- **THIS PRODUCT OR ITS FIXING MUST NOT BE MODIFIED IN ANY WAY.**

FITTING KIT NUMBER 6171433

USE	PART No	QTY	DESCRIPTION
CONTROL BOX TO BRACKET AND BULL BAR	3756499	1	BRACKET CONTROL BOX UNIV
	6151546	2	BOLT M8 x 25mm
	4584329	2	WASHER FLAT M8
	4581287	2	WASHER SPRING M8
	6151132	2	NUT M8 FLANGED
	18032	6	CABLES TIES
	EG50	2	RUBBER GROMMET
WINCH (8/9,000LB) (10/12,000LB)	4581040	4	WASHER FLAT 3/8"
	6151074	4	BOLT UNC 3/8" x 1 3/4"
	4581041	4	WASHER FLAT 7/16"
	6151079	4	BOLT UNC 7/16" x 1 1/2"
CHASSIS BRACKET TO BULL BAR	3756395L	1	BRACKET CHASSIS L/HS
	3756395R	1	BRACKET CHASSIS R/HS
	6151135	4	NUT M12
	6151095	4	BOLT M12 x 30mm
	4581050	4	WASHER SPRING 1/2"
	4581071	4	WASHER SHOULDER M12
	4581070	8	WASHER FLAT M12
CHASSIS BRACKET TO CHASSIS	4581088	2	BOLT CHASSIS RAIL EXTENSION ADJUSTER
	6151096	8	BOLT M12 x 1.25mm x 40mm
	6151135	2	NUT M12 x 1.25mm
	6151189	2	NUT M12 x 1.75mm
	4581049	2	WASHER FLAT 1/2" x 1 1/8"
	4581050	8	WASHER SPRING 1/2"
	4581007	8	WASHER HEAVY DUTY 13mm
	4581008	2	WASHER HEAVY DUTY OFFSET 13mm
	6151087	2	BOLT M10 x 25mm x 1.25mm
	6151133	2	NUT M10 x 1.25mm
	4581040	4	WASHER FLAT M10
	4581048	2	WASHER SPRING M10
BUFFERS, NUMBER PLATE, AIR DEFLECTOR, TO BULL BAR	3162141	1	BUFFER LH
	3162142	1	BUFFER RH
	3314854	1	AIR DEFLECTOR FRONT
	3314852	1	AIR DEFLECTOR EXTENSION
	6151017	13	BOLT M6 x 16mm
	6151046	13	WASHER FLAT M6
	6151128	21	NUT FLANGE M6
WINCH CABLES 8.000 / 9.000 / 10.000 LB 12,000LB	BLB850	2	CABLE BLACK 850mm
	BLR850	1	CABLE RED 850mm
	BLR2700	1	CABLE RED 2700mm
INDICATORS TO BULL BAR	3500080	1	ARB INDICATOR KIT

TOOLS REQUIRED.

Basic tool kit, torque wrench, drill, 10mm drill bit, 14mm, 16mm stepped ring spanners.

ASSEMBLY SEQUENCE FOR BULL BAR INSTALLATION.

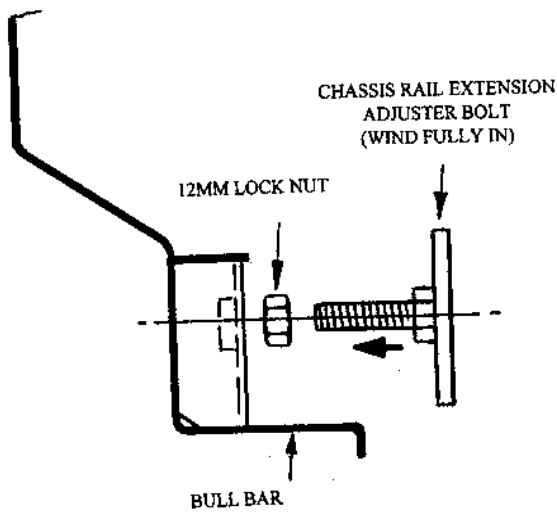

1. Fit buffers to bar using, 6mm hardware.
2. Rest the bar face down on two stands so assemble can be carried out.
3. Assemble a 12mm nut to each chassis rail extension adjuster bolt and fully screw into bull bar.
4. Do not tighten as this will be adjusted later.

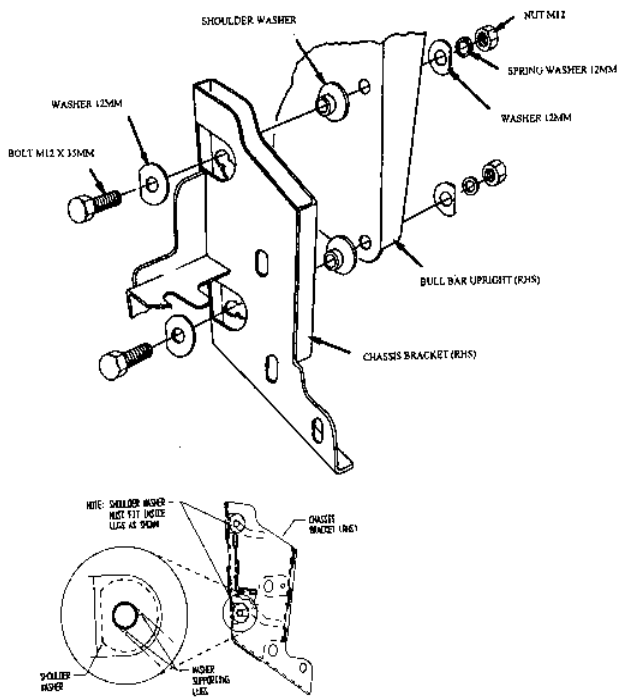

5. Assemble the two chassis brackets to the bull bar using two per side, M12 x 35mm bolts, heavy duty D washers, shoulder washers, heavy duty D washers, spring washers and nuts. Tighten the bolts and torque to 96NM or 70 FT LB.

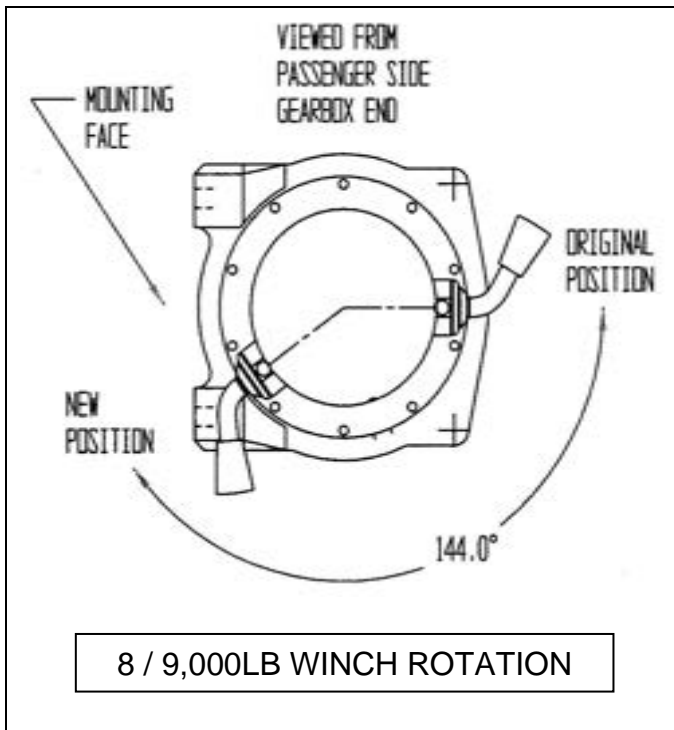

6. To place winch clutch handle in correct position for ease of operation, handle must be rotated 144° in a clockwise direction.
7. Undo and remove all capped head screws from gearbox end.
8. Gently raise the gearbox just enough to rotate to correct position. Do not completely remove the gearbox so as not to damage to the gasket.
9. Refit all capped head screws and tighten.
10. Motor end does not require rotation.

WINCH CABLE SPOOLS FROM BOTTOM OF WINCH

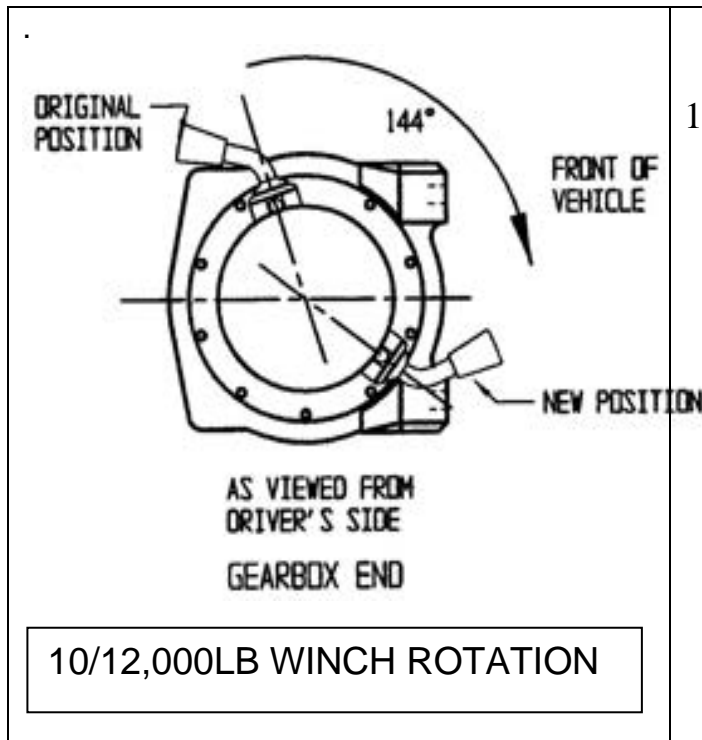

Follow instructions as above when rotating a 10/12,000LB winch.

WINCH CABLE SPOOLS FROM BOTTOM OF WINCH



11. Place winch on a stand with mounting holes facing upwards and lower bull bar onto winch. Align all four holes and secure using 1 1/2" x 7/16" bolts, 7/16" spring washers and 7/16" flat washers on 10/12,000LB winch. When using 8/9,000LB winch, secure using 1 1/2" x 3/8" bolts on top holes and 1 3/4" x 3/8" bolts on lower holes, plus 3/8" spring and flat washers.

12. When all bolts are fitted and finger tighten, centralized bolts in holes and tighten top holes only, using a stepped ring spanner.

13. Remove lower bolts.



14. Fit roller fairlead into cutout and refit bolts and tighten firmly.

NOTE. For ease of tightening lower bolts, use a stepped ring spanner to suit bolts size.



Fig A.



Fig B.

15. Fit winch control box bracket (3756499) to control box studs as shown in Fig A

16. Using M8 fasteners fit control box mounting bracket to pan, see Fig B

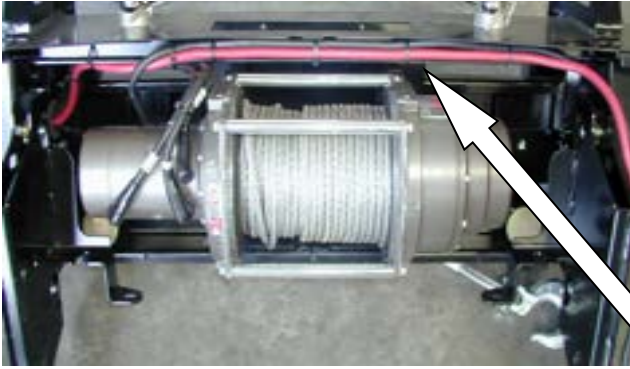

PHOTO ABOVE IS OF A 12.000LB WINCH. CONTROL BOX IS ON PASSENGER SIDE.

- 17. Connect the winch control box cables to the winch. Refer to Warn installation instruction manual when wiring up winch. **Note: before running winch cables through the bar to control box be sure to fit rubber grommets to cutouts.**
- 18. Ensure that all cables are installed well clear of all sharp or moving parts, by using cables ties from bolt kit.
- 19. Cable tie main cables that go to battery in between underside of bar and brace.



VIEWED FROM TOP OF BAR

- 20. Remove the existing bumper and grille from vehicle.
- 21. Position the bull bar on top of the chassis rails and bolt into place using the M12 x 40mm bolts, heavy duty washers and spring washers. (Do not tighten)
Adjust the bull bar to achieve a uniform gap to the grill and mudguards.
NOTE: Due to variations in the vehicle chassis rails it may be necessary to place a packer between the chassis rail top and the bull bar. A heavy duty washer is supplied for this purpose.

Refer to photo



PHOTO OF RHS OF VEHICLE.

- 22. Fit M12 x 40mm bolts, spring washers and heavy duty flat washers through bull bar side mounting holes into original bumper bar captive nut mounting holes. (Finger Tighten)
- 23. Secure lower bull bar mounting holes to vehicle tie down plates using M12 x 40mm bolt, 1/2" flat washers, heavy duty flat washers, spring washers and 12mm nuts.



- NOTE: Insert bolt from outside of lower mount hole so heavy duty washer covers large hole on tie down plate.
- 24. Tighten the bolts and torque to 110NM or 80 FT LB.



25. Once bar is secured to vehicle, using 10mm holes in chassis bracket as template, drill 10mm hole through side of chassis and secure using M10 x 40mm bolt, flat washer, spring washer and nut. Carry out this procedure on both sides of vehicle.

10MM BOLT LOCATION



26. Wind each impact absorber adjuster bolt out until it is firm against the chassis rail extensions and tighten the lock nut.



27. Remove the indicators by first removing the top screw and retaining pin then slide the lens forward. Fit the indicators to the bull bar and connect the indicator loom to the existing indicator loom with the scotchloks supplied.



Replace the indicators by sliding the indicators back into position, screw back into place then insert the retaining pin. Test to ensure the indicators function correctly.



28. The air deflector is made up of 2 panels which are bolted together using 6mm hardware when fitted to a non 4.8 litre petrol engine vehicle. Photo on left is of pan fitted to a 4.8 litre vehicle where only the front section of pan is used. Front of pan bolts to lower return of centre section of bar and to rear hanging brackets inside of pan, which are accessible through cut outs in pan.



29. If pan is fitted to a non 4.8 litre vehicle, photo on left shows both panels bolted together using 6mm hardware.



30. Fit driving lights to vehicle at this stage using lower cut outs in centre of bar for access of ratchet and extension to tighten lights to bar.



31. Fit number plate to bar using 6mm hardware.



32. Provision for Hilift jack on both sides of bar.