

January 1997

## **ARB Toyota Prado 1996**

Winch Bull Bar

**Product No. 3421010**  
Fitting Instruction No. 3782470

### **WARNING**

**THIS BULL BAR MUST NOT BE FITTED TO AIRBAG EQUIPPED VEHICLES. FITMENT TO AIRBAG EQUIPPED VEHICLES MAY INTERFERE WITH THE PROPER OPERATION OF THE AIRBAGS AND MAY RESULT IN SERIOUS INJURY.**

#### **TAKE NOTE OF THE FOLLOWING:**

- **THIS PRODUCT MUST BE INSTALLED EXACTLY AS PER THESE INSTRUCTIONS USING ONLY THE HARDWARE SUPPLIED.**
- **IN THE EVENT OF DAMAGE TO ANY BULL BAR COMPONENT, CONTACT YOUR NEAREST AUTHORISED ARB STOCKIST. REPAIRS OR MODIFICATIONS TO THE IMPACT ABSORPTION SYSTEM MUST NOT BE ATTEMPTED.**
- **DO NOT USE THIS PRODUCT FOR ANY VEHICLE MAKE OR MODEL, OTHER THAN THOSE SPECIFIED BY ARB.**
- **DO NOT REMOVE LABELS FROM THIS BULL BAR.**
- **THIS PRODUCT OR IT'S FIXING MUST NOT BE MODIFIED IN ANY WAY.**

TOOLS REQUIRED - Basic Tool Kit, 1/2" Drill & 1/2" Drill bit

#### **BULL BAR PREPARATION**

1. Rest bull bar on two stands face down so that the winch can be easily installed. Fit buffers 3162134 using M8 flange nuts.
2. Fit winch control box bracket (3756499) to control box studs as shown in Fig A.
3. Using M8 fasteners fit control box mounting bracket to pan, see Fig B .



Fig A



Fig B

4. Assemble number plate to bull bar using 2 x M6x16mm bolts, flat washers and flange nuts from bolt kit.
5. Rotate the winch gear housing 72 degrees clockwise. It is essential to refer to the Warn winch hand book for details. Refer to diagram 1.  
Rotate winch motor 90 degrees clockwise to enable cable to reach terminals. Refer to diagram 2
5. Drill the roller fairlead using a 1/2" diameter drill bit at the positions shown in diagram 3.
6. Install the winch and roller fairlead using bolts, nuts and spring washers supplied by Warn and flat washers in ARB fitting kit. Refer to Warn installation instructions for correct procedure. Connect the winch control box cable to the winch motor. Connect the long + and - cable to the vehicle after the bull bar is installed and refer to Warn winch manual for vehicle wiring instructions.  
**NOTE: Before running winch cables through the bar to control box be sure to fit rubber grommets to cutouts.**

### **FITTING PROCEDURE**

7. Remove vehicle bumper and the steel bumper support. Locate the 4 bumper location tabs under the vehicle head lamps. Push them down level with the surrounding head lamp support panel. Tie the black plastic splash panels up with cable ties in the ARB fitting kit. On the left hand side of vehicle remove the tie down bracket. On the right hand side of vehicle remove the tie down bracket and recovery hook. Discard tie down brackets and retain recovery hook and original underside M12 HT vehicle bolts from both sides. Refer to diagram 4.
8. By using outer hole in chassis as a template drill through chassis rail with 1/2" drill either side. Refer to diagram 5.
9. Using 4 x M10x25 HT bolts, flat washers and spring washers from fitting kit and original underside vehicle bolts, assemble bull bar mounting brackets onto the chassis, but do not tighten. Note: the right hand side bracket should be fitted with the tow hook. Refer to diagram 6.
10. Fit the captive nut angle brackets in between the chassis rails using the 1/2"x3 1/2" UNC bolts, flat washers and spring washers provided. (When tightening these bolts do not over tighten bolts which will cause chassis distortion.) Refer to diagram 6.
11. Install auxiliary driving lights onto the bull bar at this point if desired.
12. Using 2 people (3 if winch is fitted) carefully lift the bull bar up to the vehicle and position so it can be side mounted with 6 x M12x30mm bolts, flat washers, spring washers and nuts supplied in fitting kit. Align bull bar to vehicle and tighten the mounting bolts to the following torque: M10 bolts to 44Nm and M12 bolts to 77Nm.
13. Assemble additional indicator-park lamps to the vehicle using fitting instructions provided in indicator kit.
14. Loosen the 3 bolts on the front of stone guard and position the air deflection panel between stone guard and radiator support. Using the 8mm bolts, flat washers, spring washers and nuts supplied, bolt the panel to the bull bar mounting brackets. Tighten all bolts.

## INSTALLATION DIAGRAMS

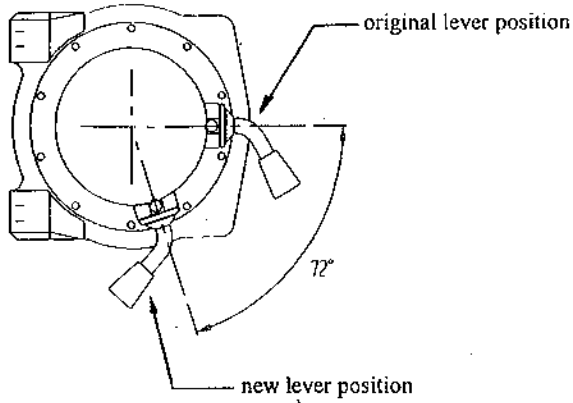

**Diagram 1 - Winch gear housing rotation**

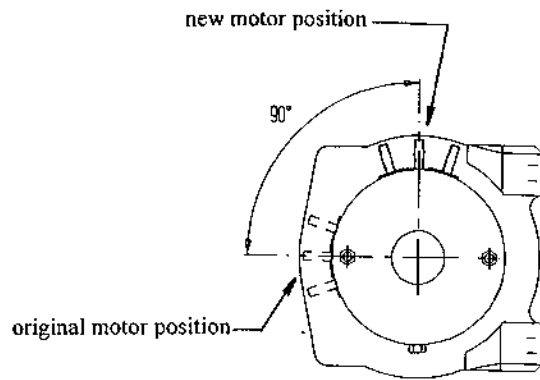

**Diagram 2 - Winch motor rotation**

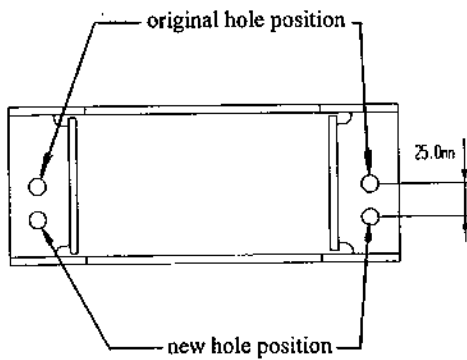

**Diagram 3 - Roller fairlead**

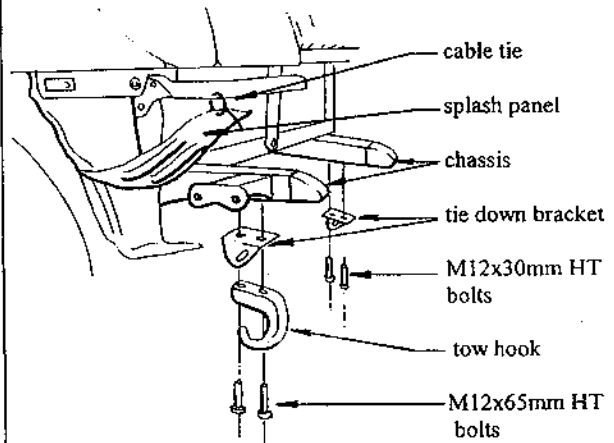

**Diagram 4 - Pre-assembly**

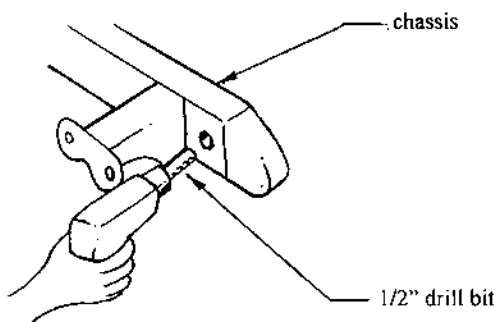

**Diagram 5- Drilling**

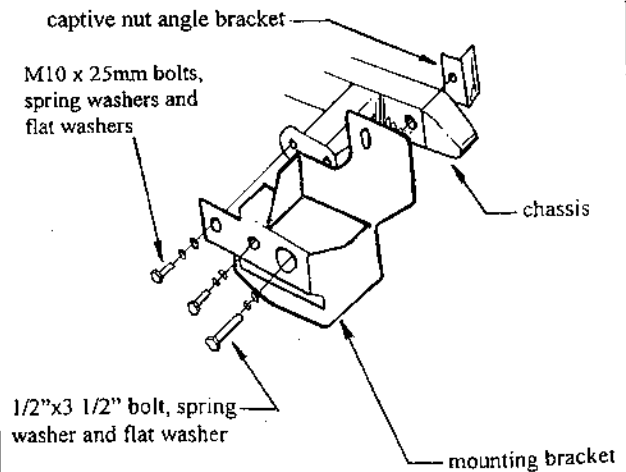

**Diagram 6 - Mounting bracket**