

ARB FITTING INSTRUCTIONS

ARB Toyota Prado 2000 ON NON FLARED MODEL Combination bar
FLARED MODEL Winch bar.

Product No. 3421040. 3421050.

WARNING

FOR VEHICLES EQUIPPED WITH SRS AIRBAG
WHEN INSTALLED IN ACCORDANCE WITH THESE INSTRUCTIONS, THE
FRONT
PROTECTION BAR DOES NOT AFFECT OPERATION OF THE SRS AIRBAG.

TAKE NOTE OF THE FOLLOWING:

- **THIS PRODUCT MUST BE INSTALLED EXACTLY AS PER THESE INSTRUCTIONS USING ONLY THE HARDWARE SUPPLIED.**
- **IN THE EVENT OF DAMAGE TO ANY BULL BAR COMPONENT, CONTACT YOUR NEAREST AUTHORISED ARB STOCKIST. REPAIRS OR MODIFICATIONS TO THE IMPACT ABSORPTION SYSTEM MUST NOT BE ATTEMPTED.**
- **DO NOT USE THIS PRODUCT FOR ANY VEHICLE MAKE OR MODEL, OTHER THAN THOSE SPECIFIED BY ARB.**
- **DO NOT REMOVE LABELS FROM THIS BULL BAR.**
- **THIS PRODUCT OR ITS FIXING MUST NOT BE MODIFIED IN ANY WAY.**

Fitting Kit. 6171408

<i>USE</i>	<i>PART No</i>	<i>QTY</i>	<i>DESCRIPTION</i>
BUFFERS TO BAR	3500200	1	BUFFER KIT
CONTROL BOX TO BAR	3756499	1	BRACKET CONTROL BOX UNIV
	6151234	2	BOLT M8 x 25
	4581045	2	WASHER FLAT M8
	4581047	2	WASHER SPRING M8
	6151132	2	NUT M8 FLANGED
	EG50	2	RUBBER GROMMET
NUMBER PLATE TO BAR	6151017	2	BOLT M6 X 16 HEX HEAD
	4581035	2	WASHER M6 FLAT
	6151128	2	NUT M6 FLANGE
MOUNTS TO VEHICLE	3756245L	1	BRACKET IMPACT ABSORBER RHS
	3756245R	1	BRACKET IMPACT ABSORBER LHS
	3751575	2	BRACKET CAPTIVE NUT
	6151103	2	BOLT 1/2" X 3 1/2" UNC
	4581049	2	WASHER M12 FLAT
	4581050	2	WASHER M12 SPRING
	6151087	4	BOLT M10 X 25
	4581048	4	WASHER M10 SPRING
	4581040	8	WASHER M10 FLAT
BAR TO CHASSIS BRACKETS	6151094	6	BOLT M12 X 30
	6151135	6	NUT M12 X 1.25
	4581049	12	WASHER M12 FLAT
	4581050	6	WASHER M12 SPRING
INDICATORS TO BAR	3500080	1	INDICATOR KIT UNIVERSAL
AIR DEFLECTOR TO BAR	6521026	1	AIR DEFLECTOR
	6151021	2	BOLT M8
	4581046	2	WASHER M8 SPRING
	6151028	2	NUT M8
	4581044	4	WASHER M8 FLAT
TO BOLT REAR OF UPRIGHT TO IMPACT ABSORBER.	6151180	2	BOLT M6 X 20 HEX HEAD
	6151046	2	WASHER M6 FLAT
	6151128	2	NUT M6 FLANGE

TOOLS REQUIRED - Basic Tool Kit, 1/2" Drill & 1/2" Drill bit

BULL BAR PREPARATION

1. Rest bull bar on two stands face down so that the winch can be easily installed. Fit buffers 3162134 using M8 flange nuts.
2.
 - A. Fit winch control box bracket (3756499) to control box studs as shown in Fig A.
 - B. Using M8 fasteners fit control box mounting bracket to pan, see Fig B .



Fig A



Fig B

3. Assemble number plate to bull bar using 2 x M6x16mm bolts, flat washers and flange nuts from bolt kit.
4. Rotate the winch gear housing 72 degrees clockwise. It is essential to refer to the Warn winch hand book for details. Refer to diagram 1.
Rotate winch motor 90 degrees clockwise to enable cable to reach terminals. Refer to diagram 2
5. Drill the roller fairlead using a 1/2" diameter drill bit at the positions shown in diagram 3.
6. Install the winch and roller fairlead using bolts, nuts and spring washers supplied by Warn and flat washers in ARB fitting kit. Refer to Warn installation instructions for correct procedure. Connect the winch control box cable to the winch motor. Connect the long + and - cable to the vehicle after the bull bar is installed and refer to Warn winch manual for vehicle wiring instructions.

FITTING PROCEDURE

7. Remove vehicle bumper and the steel bumper support. Locate the 4 bumper location tabs under the vehicle head lamps. Push them down level with the surrounding head lamp support panel. Tie the black plastic splash panels up with cable ties in the ARB fitting kit. On the left hand side of vehicle remove the tie down bracket. On the right hand side of vehicle remove the tie down bracket and recovery hook. Discard tie down brackets and retain recovery hook and original underside M12 HT vehicle bolts from both sides. Refer to diagram 4
8. Mask off the headlight, wheel guard and grill area and paint the underside of the panel using a flat black paint. See picture.

FITTING PROCEDURE



9. By using outer hole in chassis as a template drill through chassis rail with 1/2" drill either side. Refer to diagram 5.
10. Using 4 x M10x25 HT bolts, flat washers and spring washers from fitting kit and original underside vehicle bolts, assemble bull bar mounting brackets onto the chassis, but do not tighten. Note: the right hand side bracket should be fitted with the tow hook. Refer to diagram 6.
11. Fit the captive nut angle brackets in between the chassis rails using the 1/2"x3 1/2" UNC bolts, flat washers and spring washers provided. (When tightening these bolts do not over tighten bolts which will cause chassis distortion.) Refer to diagram 6.
12. Install auxiliary driving lights onto the bull bar at this point if desired.
13. Using 2 people (3 if winch is fitted) carefully lift the bull bar up to the vehicle and position so it can be side mounted with 6 x M12x30mm bolts, flat washers, spring washers and nuts supplied in fitting kit. Align bull bar to vehicle, making sure you have at least 15mm clearance between the bull bar and the vehicle then tighten the mounting bolts to the following torque: M10 bolts to 44Nm and M12 bolts to 77Nm.
14. When all bolts are torqued, secure rear of upright to impact absorber using 6mm hardware. See photo on page 5.
15. Assemble additional indicator-park lamps to the vehicle using fitting instructions provided in indicator kit.
16. Loosen the 3 bolts on the front of stone guard and position the air deflection panel between stone guard and radiator support. Using the 8mm bolts, flat washers, spring washers and nuts supplied, bolt the panel to the bull bar mounting brackets. Tighten all bolts.

INSTALLATION DIAGRAMS

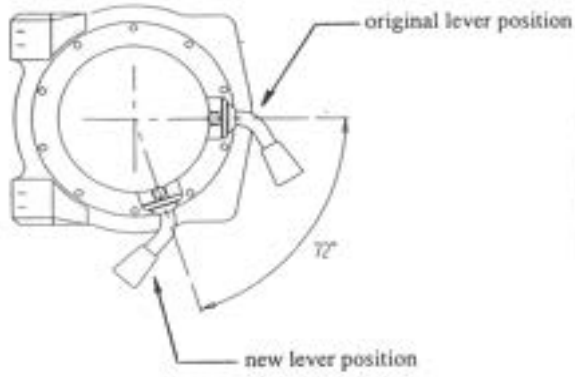

Diagram 1 - Winch gear housing rotation

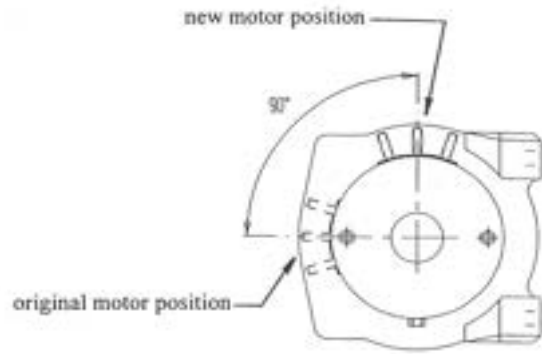

Diagram 2 - Winch motor rotation

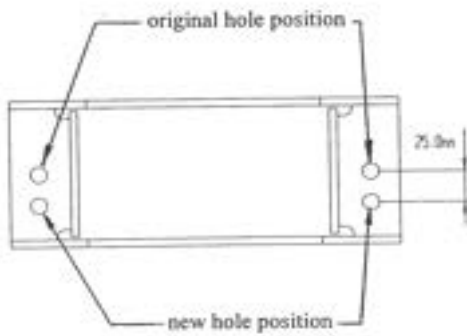

Diagram 3 - Roller fairlead

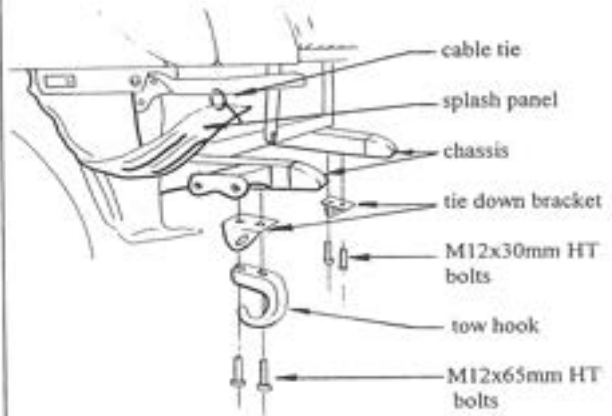

Diagram 4 - Pre-assembly

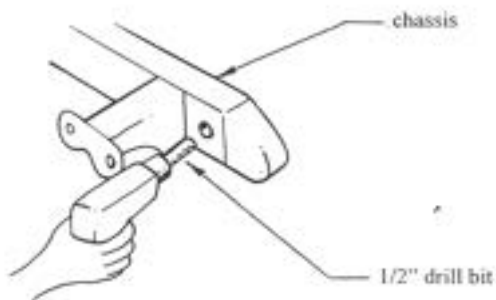

Diagram 5 - Drilling

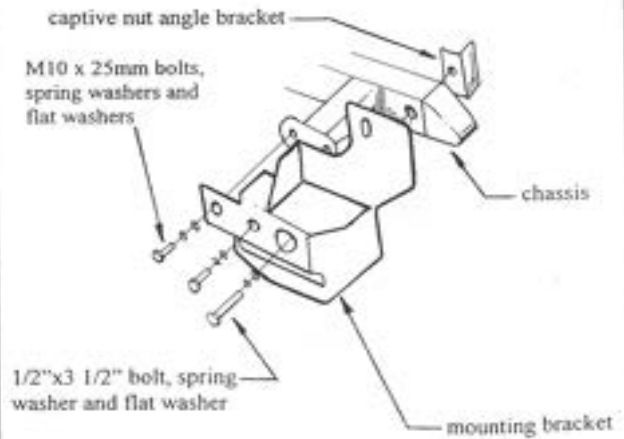

Diagram 6 - Mounting bracket



This photo shows the positioning of the 6mm bolt,nut etc to clamp the rear of the bull bar upright to the impact absorber.