

ARB COMBINATION BAR TO SUIT MITSUBISHI PAJERO NM

PRODUCT No. 3434050

WARNING

FOR VEHICLES EQUIPPED WITH SRS AIRBAG

WHEN INSTALLED IN ACCORDANCE WITH THESE INSTRUCTIONS, THE FRONT

PROTECTION BAR DOES NOT AFFECT OPERATION OF THE SRS AIRBAG.

TAKE NOTE OF THE FOLLOWING:

THIS PRODUCT MUST BE INSTALLED EXACTLY AS PER THESE INSTRUCTIONS USING ONLY THE HARDWARE SUPPLIED.

IN THE EVENT OF DAMAGE TO ANY BULL BAR COMPONENT, CONTACT YOUR NEAREST AUTHORISED ARB STOCKIST. REPAIRS OR MODIFICATIONS TO THE IMPACT ABSORPTION SYSTEM MUST NOT BE ATTEMPTED.

DO NOT USE THIS PRODUCT FOR ANY VEHICLE MAKE OR MODEL, OTHER THAN THOSE SPECIFIED BY ARB.

DO NOT REMOVE LABELS FROM THIS BULL BAR.

THIS PRODUCT OR ITS FIXING MUST NOT BE MODIFIED IN ANY WAY.

FITTING KIT No 6171404

USE	PART No	QTY	DESCRIPTION
MOUNT ASSY TO VEHICLE	3756190L	1	BRACKET IMPACT ABSORBER LHS
	3756190R	1	BRACKET IMPACT ABSORBER RHS
	3756194L	1	BRACKET FRONT MOUNT LHS
	3756194R	1	BRACKET FRONT MOUNT RHS
	3756189L	1	BRACKET CHASSIS SUPPORT LHS
	3756189R	1	BRACKET CHASSIS SUPPORT RHS
	6151246	6	BOLT M12 X 25mm
	6151232	10	BOLT M10 X 30mm
	4581007	4	WASHER Ø14 ID, Ø40 OD
	4581040	12	WASHER FLAT 3/8" X 1"
	4581048	8	WASHER M10 SPRING
	3193659	2	PLATE CAPTIVE NUT
	6151255	12	BOLT M12 X 40mm
	4581049	14	WASHER FLAT M12
	6151026	6	NUT M10
	4581050	20	WASHER SPRING M12
	6151268	6	NUT CAPTIVE
	NUMBER PLATE BRKT	6151017	4
6151046		4	WASHER FLAT M6
6151128		4	NUT FLANGE M6
3751451		1	NUMBER PLATE BRACKET
CONTROL BOX FITMENT	3756209	1	CONTROL BOX BRACKET
	4581044	2	WASHER FLAT M8
	6151021	2	BOLT M8 X 20MM
	6151128	2	NUT FLANGE M8
8-9000lb WINCH TO PAN	4581040	4	WASHER FLAT 3/8 x 1
	180302	6	CABLE TIES
BUFFERS AND INDICATORS	3500170	1	BUFFER KIT
	3500080	1	ARB INDICATORS
ROLLER FAIRLEAD FITMENT	4581040	4	WASHER FLAT 3/8"
WINCH COVER FITMENT	6151128	2	NUT FLANGE M6
	6151256	2	SCREW M6 S/STEEL BUTTON HEAD
	6191001	1	WINCH COVER EXTRUSION
	6521031	1	WINCH COVER
	4581304	2	WASHER M6 S/S

Tools Required

10mm, 18mm, 19mm, 21mm Spanners and Sockets. Phillips head screwdriver, 12mm and 13mm drill bit and drill.

IMPORTANT

- This winch bumper is suitable only for Warn 8000lb, 9000lb & 9500lb HIGH SPEED winches only.

ASSEMBLY SEQUENCE FOR WINCH BUMPER.

1.

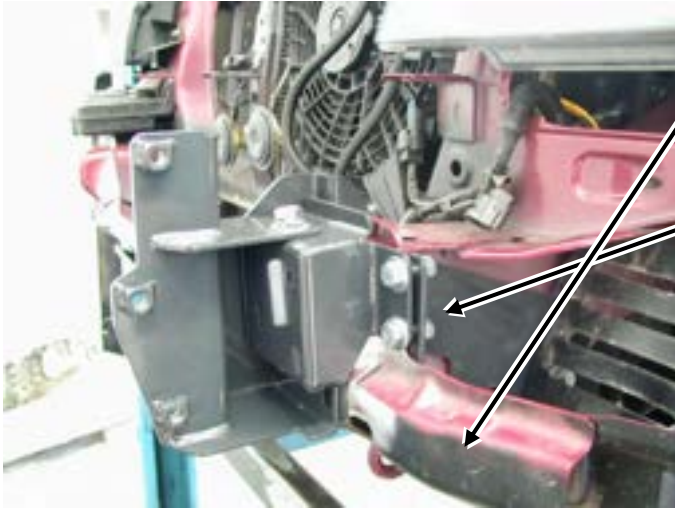

1. Remove the bumper bar and grill.
2. Spray paint the vehicles cross member and radiator lower support panels with matt black spray paint on both sides.
3. Assemble the mounts to the vehicle as shown in the pictures 7 & 8. Fasten bolts finger tight only.

M10 x 30mm bolts, flat washers, spring washers and nuts.

2.



M12 x 25mm bolts, flat washers and spring washers.

3.



4. Using a 12mm drill bit, drill through the two slot holes at the front into the chassis cross member.

4.

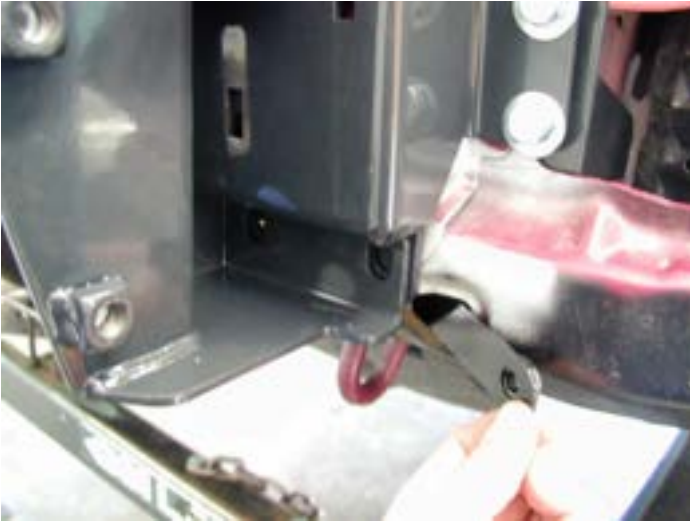

5. Feed the captive nut plate through the hole in the cross member and fasten using M10 bolts, flat washers and spring washers.

5.

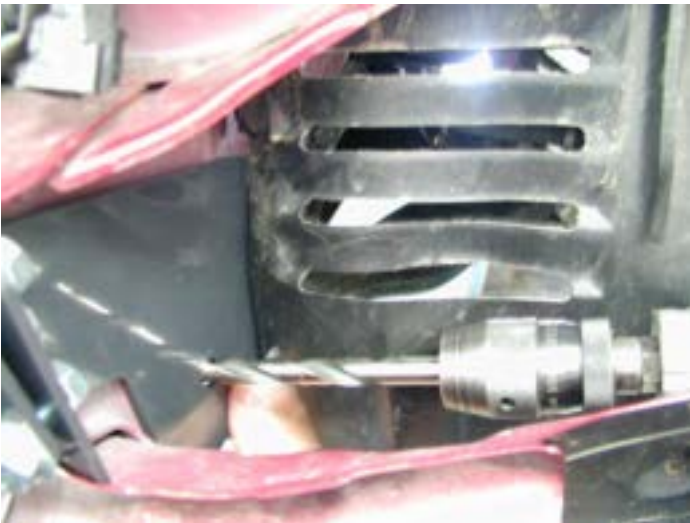

6. Using a 13mm drill bit, drill through the holes in the outside bracket and into the chassis rail.

6.



7. Using a 13mm drill bit, drill through the hole in the main bracket and into the chassis rail.

7.



8. The mounting bolts for the drilled holes are fastened using the captive nuts with extension arms. Feed these through the hole underneath the chassis rail. The wire can be manipulated to shape for easier installation.

8.



9. Fasten the brackets using the M12 x 40mm bolts, Large washers and spring washers.
Note: The inside bolt uses a small M12 washer.

9.



Note: The washer bottle on the drivers side must be removed to gain access to the top bolt.

10. Tighten all bolts.

10.

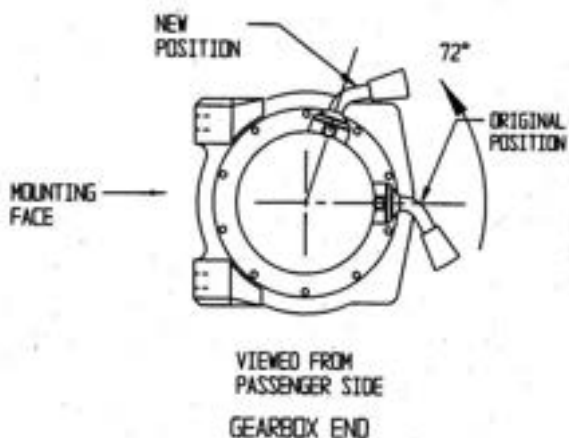

(If fitting the winch.)

11. To place the winch clutch handle in a convenient location the winch gearbox must be rotated 2 hole spacings, 72 degrees, in an anti-clockwise direction when viewed from the gearbox end. Place the winch on its end and remove all gearbox bolts. Gently raise the gearbox just enough to rotate it. Do not completely remove the gearbox and avoid damaging the gasket. Refit all bolts and tighten.

NOTE: Take care not to lift the assembly more than a couple of millimetres while rotating to the desired position to avoid unmeshing the gears.

11.

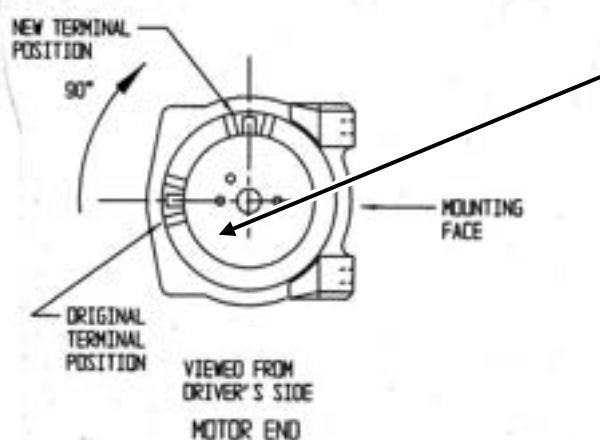

12. To place the winch motor in the correct location the winch motor must be rotated 90 degrees, in a clockwise direction when viewed from the motor end. Place the winch on its end and remove the 2 motor retaining bolts. Gently raise the motor just enough to rotate it. Do not completely remove the motor and avoid damaging the gasket. Refit all bolts and tighten.

NOTE: Take care not to lift the assembly more than a couple of millimetres while rotating to the desired position to avoid unmeshing the gears.

12.



13. The roller fairlead must be drilled out using 12mm drill bit, see diagram below. Bolt the winch and roller fair lead to the bar using the bolts supplied. The longer bolts are used for the two bottom holes through the roller fair lead.

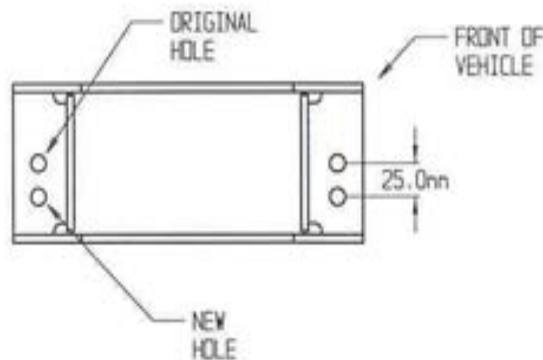

13.



14. Install the winch and roller fairlead using bolts, nuts and spring washers supplied by Warn, and the 4 x 3/8" flat washers supplied in the bolt kit. Refer to Warn installation instructions for correct procedure. Adjust winch in slots until the winch is centralised in the bull bar.

15. Assemble the control box bracket to the control box using M6 flange nuts.

16. Mount the control box to the bar using M8 X 20 bolts and M8 flange nuts.

Note: The gearbox is on the passenger side for the 8,000lb and 9,000lb. The cable spools from the bottom for the two winches mentioned.

14.



(If not fitting winch)

17. Wrap rubber extrusion around winch cover.

18. Place stainless steel washers over the winch cover fixing holes located on the top middle face of the winch bumper.

19. Place the winch cover on top of the winch bumper inline with the mount holes.

Bolt together using the M6 button head stainless steel screws and M6 nuts.

15.



With winch



Without winch

(If fitting with winch.)

20. Bolt number plate bracket to bar using 6mm hardware.

21. Bolt number plate to number plate bracket using 6mm hardware.

(If not fitting with winch.)

22. Bolt the number plate through the lower holes using M6 X 16mm bolts and M6 flange nuts so number plate covers roller fairlead cutout.

16.

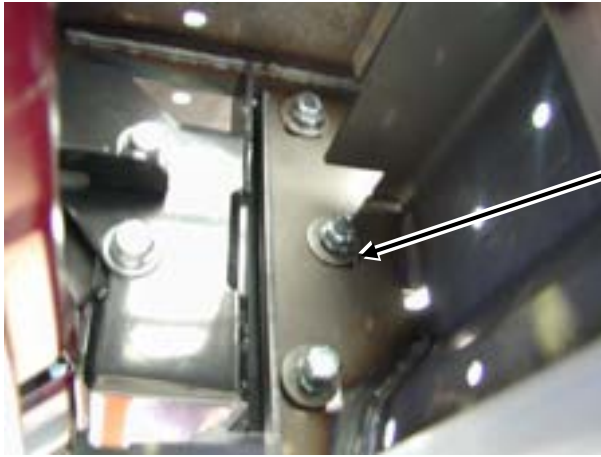

23. With the aid of another person place the bar on the mounts. Line the bar to the vehicle with a 10 - 15mm gap between vehicle and bar. Fasten using six M12 x 40mm bolts six ½" washers and six spring washers. Tighten all bolts firmly.

17.



24. Cut the excess wires from under the vehicle so they don't protrude past the chassis rail.

18.



25. Place the rubber caps over the cut ends of the wires.

19.



26. Next step is to lock pin the bar so there is no movement by drilling a 10mm hole on both sides of vehicle, and fasten with 10mm x 25mm bolts plus 10mm hardware.

20.



(If fitting with winch)

27. Feed the winch cable through the roller fair lead. Mount the hook to the end of the cable.

(If fitting with winch)

Connect the winch control box cables to the winch motor. Refer to the Warn handbook for additional information. Connect the long winch + & - cables to the vehicle after the bar is installed.

Refer to the Warn winch manual for vehicle wiring instructions.

Ensure that these cables are installed well clear of sharp, hot or moving objects. Secure the winch cables to the vehicle and winch bumper with the supplied cable ties.