

ARB FITTING INSTRUCTIONS

ARB WINCH BULL BAR TO SUIT

HOLDEN JACKAROO STD, SE & MONTEREY 1998-2001

HOLDEN JACKAROO STD 2001 ON

No 3444060

ARB WINCH BULL BAR TO SUIT

HOLDEN JACKAROO WIDE BODY SE & MONTEREY 2001 ON

No 3444070

WARNING

FOR VEHICLES EQUIPPED WITH SRS AIRBAG
WHEN INSTALLED IN ACCORDANCE WITH THESE INSTRUCTIONS, THE FRONT PROTECTION BAR DOES NOT AFFECT OPERATION OF THE SRS AIRBAG.

TAKE NOTE OF THE FOLLOWING:

- **THIS PRODUCT MUST BE INSTALLED EXACTLY AS PER THESE INSTRUCTIONS USING ONLY THE HARDWARE SUPPLIED.**
- **DO NOT USE THIS PRODUCT FOR ANY VEHICLE MAKE OR MODEL, OTHER THAN THOSE SPECIFIED BY ARB.**
- **DO NOT REMOVE LABELS FROM THIS BULL BAR.**
- **THIS PRODUCT OR ITS FIXING MUST NOT BE MODIFIED IN ANY WAY.**

BULL BAR FITTING KIT No 6171299

USE	PART No	QTY	DESCRIPTION
CHASSIS BRACKET TO VEHICLE	3751747R	1	CHASSIS BRACKET (RHS)
	3751747L	1	CHASSIS BRACKET (LHS)
	6151096	4	M12 X 40mm BOLT
	4581050	4	M12 SPRING WASHER
	4581049	4	M12 FLAT WASHER
	6151135	2	M12 NUT
	4581057	2	CRESCENT MOON WASHER
	4581008	2	OFFSET WASHERS
	5846277	4	PACKER
PIN BULL BAR TO VEHICLE	6151087	2	M10 X 25mm BOLT
	4581040	4	M10 FLAT WASHER
	4581048	2	M10 SPRING WASHER
	6151133	2	M10 NUT
BULL BAR TO CHASSIS BRACKETS	6151094	6	M12 X 30mm BOLT
	4581050	6	M12 SPRING WASHER
	4581049	12	M12 FLAT WASHER
	6151135	6	M12 NUT
	6151087	2	M10 X 25mm BOLT
	4581040	4	M10 FLAT WASHERS
	4581048	2	M10 SPRING WASHERS
	6151133	2	M10 NUT
CONTROL BOX BRACKET TO BULL BAR	3759155	1	CONTROL BOX BRKT JACKAROO 98on
	6151234	2	BOLT M8 x 25mm
	4581045	2	WASHER FLAT M8
	4581047	2	WASHER SPRING M8
	6151132	2	NUT M8 FLANGED
	EG50	2	RUBBER GROMMET
NUMBER PLATE TO BAR	6151017	2	M6 X 16mm BOLT
	6151128	2	M6 FLANGE NUT
	4581035	4	M6 X 16OD FLAT WASHER
WINCH TO BAR	4581040	4	M10 FLAT WASHER
	3500080	1	ARB INDICATOR KIT
	180302	4	CABLE TIES
	3500200	1	BUFFER KIT

TOOLS REQUIRED

Basic tool kit, drill, 10mm and 12mm drill bits.

FITTING THE 9,000lb WINCH

1. Place the bull bar on a suitable stand.
2. To place the winch clutch handle in a convenient location the winch gearbox must be rotated 4 hole spacings, 144 degrees, in an anti-clockwise direction when viewed from the gearbox end. Place the winch on its end and remove all gearbox bolts. Gently raise the gearbox just enough to rotate it. Do not completely remove the gearbox and avoid damaging the gasket. Refit all bolts and tighten. (Refer to diagram 1.)

NOTE: The winch handle is positioned near the bottom of the bull bar. The gearbox is situated on the left hand side of the bull bar (as viewed from inside the vehicle). The cable spools from the bottom.

DIAGRAM 1

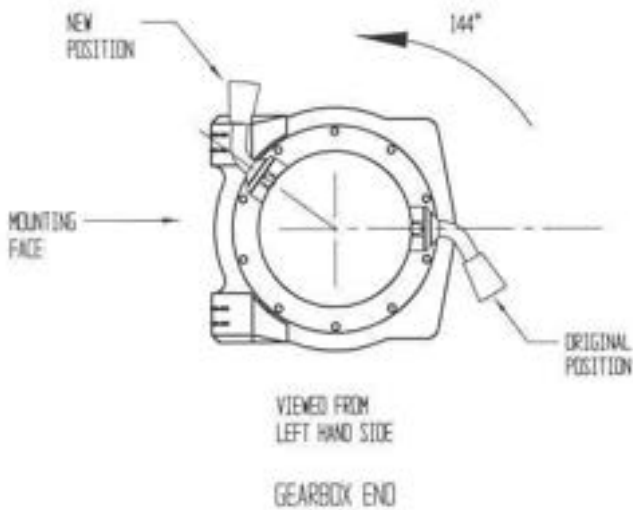
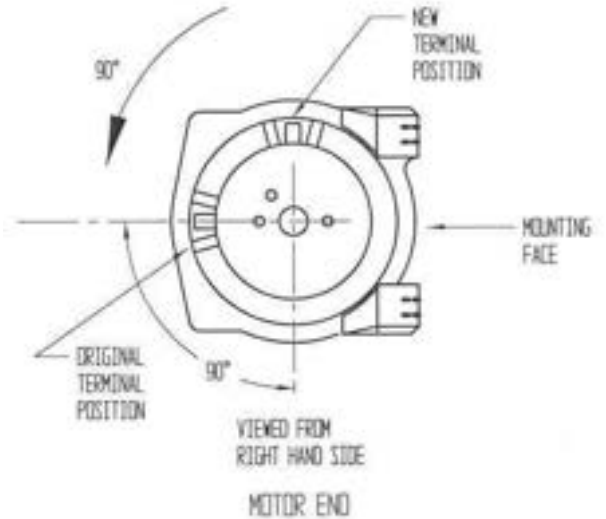
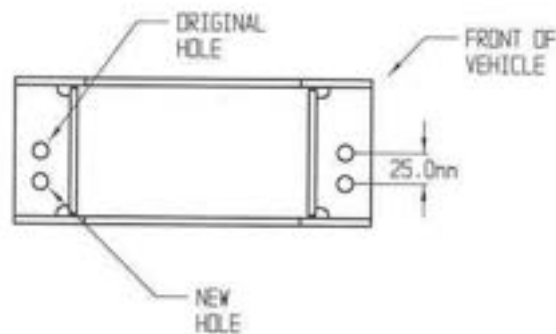

DIAGRAM 2



3. To place the winch motor in the correct location the winch motor must be rotated 90 degrees, in a clockwise direction when viewed from the motor end. Place the winch on its end and remove the two motor retaining bolts. Gently raise the motor just enough to rotate it. Do not completely remove the motor and avoid damaging the gasket. Refit all bolts and tighten. (Refer to diagram 2.)
4. The roller fairlead must have new holes drilled to allow for correct wire rope angle. Using a 12mm diameter drill bit, redrill the roller fairlead as shown. (Refer to diagram 3.)

DIAGRAM 3



- A. Fit winch control box bracket () to control box studs as shown in Fig A.
- B. Using M8 fasteners fit control box mounting bracket to pan, see Fig B .



Fig A



Fig B

5. Fit the winch and roller fairlead into the bull bar using bolts from the winch kit and four M10 washers from the ARB bolt kit.
6. Connect the winch control box cables to the winch motor. Refer to the Warn handbook for additional information. Connect the long winch + & - cables to the vehicle after the bull bar is installed. **Refer to the Warn winch manual for vehicle wiring instructions.**
7. **NOTE:** Ensure that these cables are installed well clear of sharp, hot or moving objects. Secure the winch cables to the bull bar with the cable ties supplied.

FITTING THE BULL BAR TO THE VEHICLE

8. Remove the bumper from the vehicle.
9. Fit the chassis brackets (Part No. 3751747 L&R) to both sides of the vehicle using two M10 x 25mm bolts and four M12 x 40mm bolts, crescent moon washers, offset washers, flat washers, spring washers and nuts. (Refer to diagram 4.) Fit two 6mm spacers between inside of chassis bracket and on outside of vehicle chassis rail and align with 12mm captive nut and secure using 12mm hardware. Finger tighten only

DIAGRAM 4

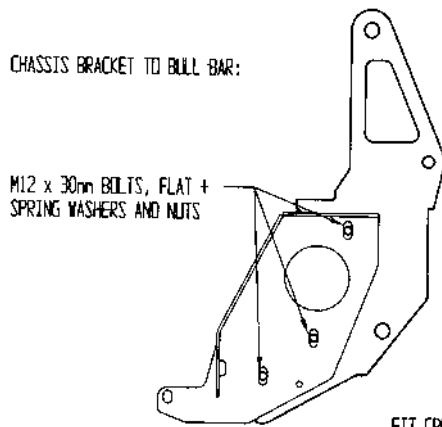
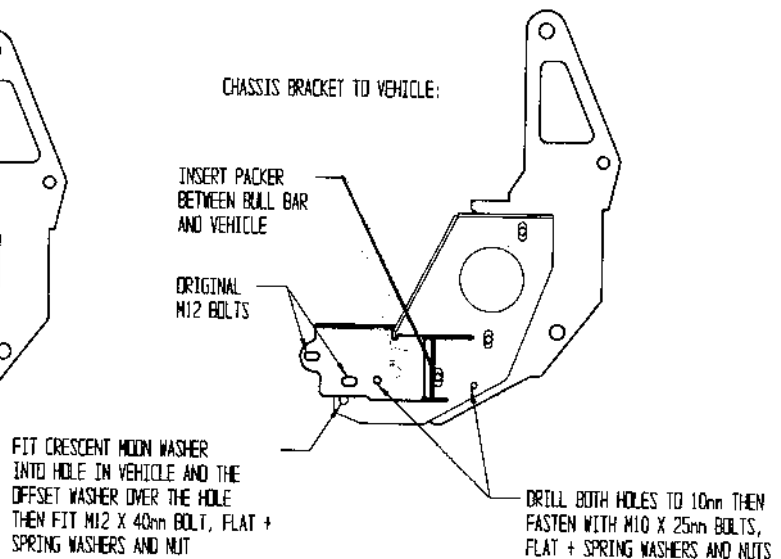

DIAGRAM 5



10. Assemble the two buffers on to the bull bar using the four M8 flange nuts supplied.
11. Lift the bull bar between the chassis bracket and bolt up using the M12 x 30mm bolts, flat washers, spring washers and nuts. Align the bar horizontally and vertically. Make sure there is a gap between 20 and 25mm between the bull bar and the vehicle grill and guards.
12. When correctly aligned, tighten all the bolts firmly.
13. Drill and pin using the M10 x 25mm bolts, flat washers, spring washers and nuts. (Refer to diagram 5.)
14. Fit the number plate to the bull bar using the two M6 x 16mm bolts, flat washers and flange nuts.
15. Fit the indicators into the cut outs in the bull bar and connect the indicator looms to the existing indicator loom.
NOTE: Fitting the indicators will be accessed from underneath the bar. Test to ensure the indicators function correctly.