



# FITTING INSTRUCTIONS

Part Number: **3450410**  
Product **DELUXE BULLBAR**  
Description:  
Suited to **JEEP GRAND CHEROKEE WK2 2011-2014 ON (EXCLUDING SRT8)**  
vehicle/s: **INCLUDING TRAILHAWK**  
Winch install **3540050**  
kit:  
Radar install **3550100**  
kit:

## WARNING

### REGARDING VEHICLES EQUIPPED WITH SRS AIRBAG:

When installed in accordance with these instructions, the front protection bar does not affect operation of the SRS airbag.

### ALSO, NOTE THE FOLLOWING:

- ◆ This product must be installed exactly as per these instructions using only the hardware supplied.
- ◆ In the event of damage to any bull bar component, contact your nearest authorised ARB stockist. Repairs or modifications to the impact absorption system must not be attempted.
- ◆ Do not use this product for any vehicle make or model, other than those specified by ARB.
- ◆ Do not remove labels from this bull bar.
- ◆ This product or its fixing must not be modified in any way.
- ◆ The installation of this product may require the use of specialized tools and/or techniques
- ◆ It is recommended that this product is only installed by trained personnel
- ◆ These instructions are correct as at the publication date. ARB Corporation Ltd. cannot be held responsible for the impact of any changes subsequently made by the vehicle manufacturer
- ◆ During installation, it is the duty of the installer to check correct operation/clearances of all components
- ◆ Work safely at all times
- ◆ Unless otherwise instructed, tighten fasteners to specified torque

## ARB 4x4 ACCESSORIES

### Corporate Head Office

42-44 Garden St  
Kilsyth, Victoria  
AUSTRALIA 3137

Tel: +61 (3) 9761 6622  
Fax: +61 (3) 9761 6807

Australian enquiries  
North & South American enquiries  
Other international enquiries

sales@arb.com.au  
sales@arb.com.au  
exports@arb.com.au

[www.arb.com.au](http://www.arb.com.au)

# GENERAL CARE AND MAINTENANCE

By choosing an ARB Bar, you have bought a product that is one of the most sought after 4WD products in the world. Your bar is a properly engineered, reliable, quality accessory that represents excellent value. To keep your bar in original condition it is important to care and maintain it following these recommendations:



- Prior to exposure to the weather your bar should be treated to a Canuba based polish on all exposed surfaces. It is recommended that this is performed on a six monthly basis or following exposure to salt, mud, sand or other contaminants.
- As part of any Pre Trip Preparation, or on an annual basis, it is recommended that a thorough visual inspection of the bar is carried out, making sure that all bolts and other components are torqued to the correct specification. Also check that all wiring sheaths, connectors, and fittings are free of damage. Replace any components as necessary. This service can be performed by your local authorized ARB Stockist.

## FITTING REQUIREMENTS

### REQUIRED TOOLS FOR FITMENT OF PRODUCT:

BASIC TOOL KIT	MASKING TAPE
MARKER PEN	HACKSAW BLADE / JIGSAW OR SIMILAR
TORQUE WRENCH	SOLDERING IRON AND SOLDER
ELECTRICAL TAPE OR EQUIV.	

### HAVE AVAILABLE THESE SAFETY ITEMS WHEN FITTING PRODUCT:

Protective eyewear 	Hearing protection 
--------------------------------------------------------------------------------------------------------	----------------------------------------------------------------------------------------------------------

**NOTE: 'WARNING' notes in the fitting procedure relate to OHS situations, where to avoid a potentially hazardous situation it is suggested that protective safety gear be worn or a safe work procedure be employed. If these notes and warnings are not heeded, injury may result.**

### FASTENER TORQUE SETTINGS:

SIZE	Torque Nm	Torque lbft
M6	9Nm	7lbft
M8	22Nm	16lbft
M10	44Nm	32lbft
M12 x1.75	77Nm	57lbft
M12 x 1.25	96Nm	71lbft

PARTS LISTING			
APPLICATION.	PART NO.	QTY	DESCRIPTION
<b>PREPARE VEHICLE</b>	3759170R	1	BRACKET ASSEM MOUNT WK2 GC RH
	3759170L	1	BRACKET ASSEM MOUNT WK2 GC LH
	3759182	1	COMPRESSOR BRACKET
	4581050	6	WASHER SPRING 1/2 x 3/16 x 3/16 ZP
	4581046	4	WASHER SPRING M8 x 3/32 x 3/32
	4581047	2	WASHER SPRING M8 x 3/32 x 3/33 BLK ZN
	6151480	4	NUT FLANGE M12 X 1.25 ZP
	6151132	2	NUT FLANGE M8 x 1.25 ZP
	4581011	6	WASHER FLAT, M12 x 27 x 4
	4581063	4	WASHER FLAT, M8 x 25 x 3 GOLD ZN
	4581085	2	WASHER FLAT, M8 x 19 x 1.2 BLK ZN
	6151096	6	BOLT HXHD M12 X 1.25 X 40 CL8.8 ZP
	6151022	4	BOLT M8 x 1.25 x 25 Gd 8.8 ZP
	6151234	2	BOLT M8 x 1.25 x 25 Gd 8.8 BP
	4681454	2	BRACE CHASSIS BASE WK2 GC
	6821152	2	LOOM
	3789167	1	TEMPLATE BUMPER CUT JEEP GC WK2
	6151357	4	BOLT SEMS M10 X 30 ZP Gd 8.8
<b>PARKING SENSORS</b>	EG50	4	GROMMET RUBBER
	3759181	4	BRACKET PARKING SENSOR MOUNT
	3759187	2	BRACKET PARKING SENSOR MOUNT
	665044	1	3M PRIMER STICK
	6781427	6	ADHEASIVE STRIP BUTYL 20 X 25
	6781437	12	3M4991 – 2.3MM VHB TAPE 20X25
	3163091	6	PLUG BLANKING BLK
<b>IMPACT ABSORBERS</b>	3789168	1	FITTING KIT BULLBAR JEEP GC WK2
	3194531	1	PLATE IMPACT SLIDE WK2 JEEP GC
	6151207	4	BOLT HX HD M6 x 1.0 x 25 GR8.8 TZP480
	4581036	4	WASHER SPRING 1/4" x 3/32" x 3/32" ZP
	4581050	2	WASHER SPRING 1/2 x 3/16 x 3/16 ZP
	4581049	2	WASHER FLAT, 1/2 x 1 1/8 x 3 GOLD ZN
	6151046	4	WASHER FLAT, M6 ZP
	6151128	4	NUT FLANGE M6 x 1.0 ZP
	6151321	2	NUT FLANGE M10 x 1.5 ZP
	3194532	2	PLATE ASSEM IMP ABS JEEP WK2 GC
	3194531L	1	PLATE IMPACT SLIDE WK2 JEEP GC
	4584352	2	WASHER NYLON 12 X 25 X1.5
6151658	2	BOLT SHOULDER M12 X 16	
<b>FIT BAR TO VEHICLE</b>	4681460	2	BRACE PLATE JEEP WK2 GC RH
	5848394	8	PACKER WK2 JEEP GC
	4581050	6	WASHER SPRING 1/2 x 3/16 x 3/16 ZP
	6151480	6	NUT FLANGE M12 X 1.25 ZP
	6151096	6	BOLT HXHD M12 X 1.25 X 40 CL8.8 ZP
<b>FOG/TURN/CLEARANCE LIGHTS</b>	6821151R	1	INDICATOR RH
	6821151L	1	INDICATOR LH
	3163014	1	FOG LIGHT SURROUND KIT

PARTS LISTING			
APPLICATION	PART NO.	QTY	DESCRIPTION
BUFFERS	3162470R	1	BUFFER RH
	3162470L	1	BUFFER LH
	6151128	12	NUT FLANGE M6 x 1.0 ZP
UNDER PANELS	6522917	1	PANEL STONE SHIELD WK2 JEEP GC
	6522916	1	PANEL UNDER WING WK2 GC RH
	6522916L	1	PANEL WING JEEP GC WK2 LH
	6173542	1	F/KIT BAGGED BULLBAR JEEP GC WK2
	6151262	2	BOLT M8 x 1.25 x 20 Gd 8.8 BZ
	6151550	17	BOLT HXHD M6 x 1.0 x 25 GR8.8 BTZP480
	4581047	2	WASHER SPRING M8 x 3/32 x 3/33 BZ
	4581287	17	WASHER SPRING M6 x 2.5 x 1.6 BLK ZN
	4581085	2	WASHER FLAT, M8 x 19 x 1.2 BLK ZN
	4581082	17	WASHER FLAT, M6 x 19 x 1.6 BZ
	6151132	2	NUT FLANGE M8 x 1.25 ZP
	6151300	14	NUT CAGED M6 2.6-3.5
WINCH FITMENT	3759183	1	BRACKET WINCH SOCKET
	EG50	2	GROMMET RUBBER
	6151128	4	NUT FLANGE M6 x 1.0 ZP
	6151282	2	NUT FLANGE M5 x 0.8 ZP
	3759201	1	BRACKET SOLENOID JEEP WK2
	4581287	7	WASHER SPRING M6 x 2.5 x 1.6 BLK ZN
	6151550	7	BOLT HXHD M6 x 1.0 x 25 GR8.8 BTZ
	6151300	3	NUT CAGED M6 2.6-3.5
	4584295	7	WASHER FLAT M6 X 12 X 1.3 BLK ZN
	3540050	1	WINCH INSTALL KIT
INNER GUARD RETENTION	4581287	4	WASHER SPRING M6 x 2.5 x 1.6 BZ
	4581305	4	WASHER SPRING M6 x 2.5 x 1.6 S/S
	6151300	4	NUT CAGED M6 2.6-3.5
	4584295	4	WASHER FLAT M6 X 12 X 1.3 BLK ZN
	4581304	4	WASHER FLAT, M6 SS
	6151256	4	SCREW BTN HD M6 x 16 SS
	6151459	4	SCREW BTN HD M6 x 16 BZ
	3194584	2	PLATE INNER GUARD RET WK2
FIT RADAR TO VEHICLE	3550100	1	WK2 RADAR KIT SUIT 3450410-20
MISC	180302	10	CABLE TIE 4.8 X 180 MM BLACK
	2125449	1	LABEL TOW WARNING
LICENSE PLATE FIT	3500510	1	FOLDING NUMBER PLATE BRACKET
	6151128	2	NUT FLANGE M6 x 1.0 ZP
	3194532	1	PLATE ASSEM IMP ABS JEEP WK2 GC
	4581304	2	WASHER FLAT, M6 SS
	6151256	2	SCREW BTN HD M6 x 16 SS

## FITTING PROCEDURE



1. Park the vehicle on a flat surface and open the hood.
2. Remove the 3 screws and 1 plug holding the stone shield to the cross beam and discard.
3. Remove the 2 screws holding the stone shield to the wheel arch inner guards and discard. Allow the stone shield to hang down.
4. Undo and discard the 5 quarter turn plastic clips holding the bumper to the vehicle.



5. Carefully unclip the flare trims from the bumper. Leave attached to the guards.



6. With the assistance of another person remove the bumper from the vehicle by carefully unclipping the outside edges of the bumper and rotating the outwards and forward.
7. As the bumper comes away from the vehicle, unplug the head light washers from the reservoir, unplug the fog lights at the light plug and if fitted, disconnect the parking sensors at the plug under the head lamp.



8. Remove the foam panel from the crash beam and discard.
9. Remove the crash beam/s from the vehicle and discard.
10. Remove the plastic bracket that attaches the wiring loom to the crash beam and discard.

## FITTING PROCEDURE



11. If the vehicle is fitted with adaptive cruise control, remove the radar sensor and mount bracket from the crash beam by unplugging the sensor and removing the 2 x screws in the bottom face of the beam,



12. Place the radar sensor in a safe place where it will not be damaged.



13. Remove the grill by undoing the screw below each head lamp and unclipping the top panel of the grille. Retain the screws and place the grille in a safe place where it will not be damaged.



14. On each head lamp, undo the 2 x screws holding the bottom of the lamp to the vehicle. Retain screws.

## FITTING PROCEDURE



15. Unclip the panels that sit on top of each head lamp. Retain clips.
16. Lift the panel away from the head lamp.
17. Undo the screw holding the top of each head lamp. Retain screws.



18. Carefully pull each head lamp away from the vehicle allowing them to hang on their wiring looms.

Description	Loom Wire Colour	Vehicle Cable Colour
RH TURN SIGNAL	GREEN	WHITE/BROWN
LH TURN SIGNAL	GREEN	WHITE/GREEN
RH CLEARANCE	RED	WHITE/RED
LH CLEARANCE	RED	WHITE/PURPLE
EARTH	BLACK	BLACK

19. On each head lamp identify the wiring plug for the indicators and the clearance lamps.
20. Using a soldering iron and solder, connect the supplied indicator clearance looms to each side of the vehicle as per the table shown to the left.
21. Cover all joints with electrical tape or similar.
22. Route the looms down below the head lamps under the vehicle sheet metal so that they can be attached to the bulbar later.
23. Replace the head lamps by reversing the above steps.



24. Refit the grille by reversing the above steps.
25. Place masking tape on the front of the grille as shown to protect it during modifications.

## FITTING PROCEDURE



26. Using a marker pen, mark a line, parallel to the front edge of the lower bumper skirt, 25mm from the edge.



27. On each side of the grille skirt, mark a line 65mm out board from the outboard most clip indentation, perpendicular to the front edge.



28. Using a hacksaw blade, jig saw or similar, carefully cut along the line marked in the steps above and remove and discard the front section.
29. Use a file or sandpaper to remove any sharp edges.



**Warning:** Drilling operations can result in flying metal debris, safety glasses should be worn.



30. Apply masking tape to both sides of the bumper as shown.



## FITTING PROCEDURE



31. Carefully cut out the supplied cutting template and attach to the RH hand side of the bumper as shown.
32. Use a marker pen to trace along the bottom edge of the template.
33. Carefully remove the template from the bumper.
34. Attach the template to the LH side of the bumper on the reverse side.
35. Mark along the bottom edge of the template.
36. Remove the template.



37. Mark a line from the end point of the lines marked above along the bumper style line as shown. Repeat on other side.



38. On the top edge of the bumper where the grille sits, locate the small raised bump.
39. From the bump, mark a line perpendicular to the back edge until it intersects with the line marked above. Repeat on other side.



40. Using a hacksaw blade, jig saw or similar, carefully cut along the line marked in the steps above and retain the corner pieces as shown.
41. Use a file or sandpaper to remove any sharp edges.



**Warning: Drilling operations can result in flying metal debris, safety glasses should be worn.**

## FITTING PROCEDURE



42. Reattach the bumper pieces to the vehicle by reversing the above steps.
43. Reattach the flare trims to the bumper pieces.
44. Use masking tape to mark a line as shown along the flare trims.



45. Using a hacksaw blade, jig saw or similar, carefully cut along the line marked in the steps above and remove the lower sections of the flare trims. Discard cut off pieces.
46. Use a file or sandpaper to remove any sharp edges.



**Warning:** Drilling operations can result in flying metal debris, safety glasses should be worn.



47. Attach pinch weld to each side of the vehicle as shown.

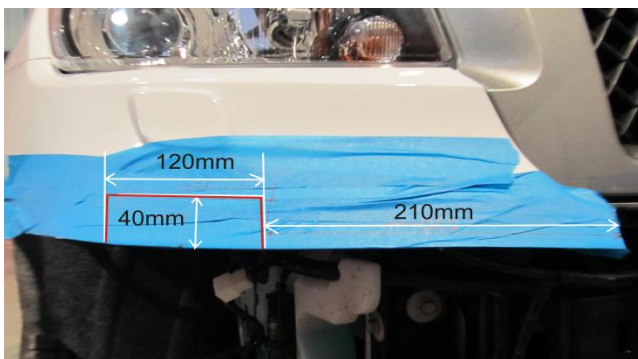

48. Mark a rectangle as per the dimensions shown, perpendicular to the bottom edge of the cut bumper. Repeat both sides.

## FITTING PROCEDURE

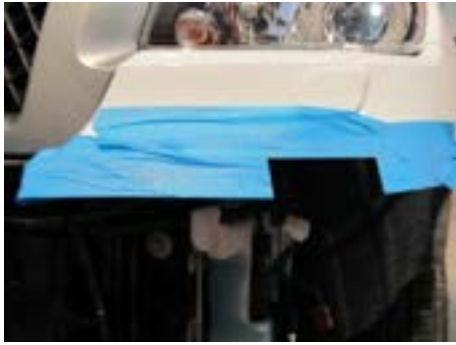

49. Using a hacksaw blade, jig saw or similar, carefully cut along the line marked in the steps above and remove the rectangular sections of the flare trims. Discard cut off pieces.
50. Use a file or sandpaper to remove any sharp edges.



**Warning:** Drilling operations can result in flying metal debris, safety glasses should be worn.

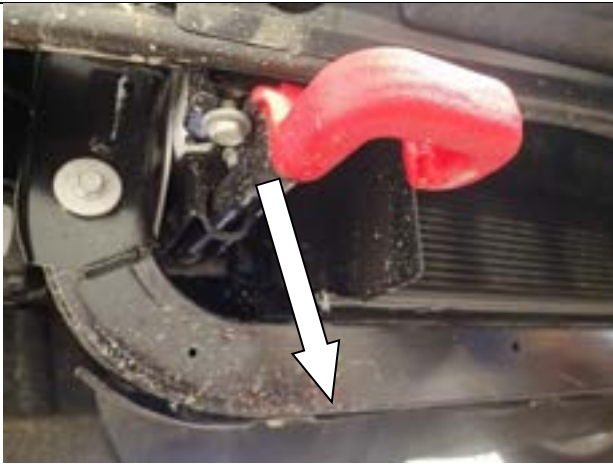

51. If fitted, remove any recovery points.

**Note:** These cannot be re-fitted to the ARB bar.

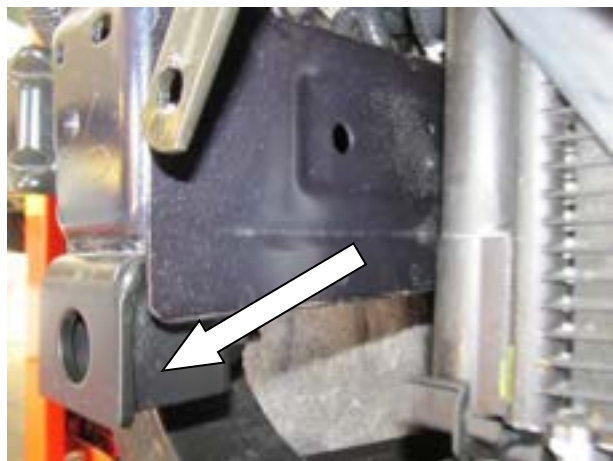

52. If fitted, remove the factory tow point and discard.

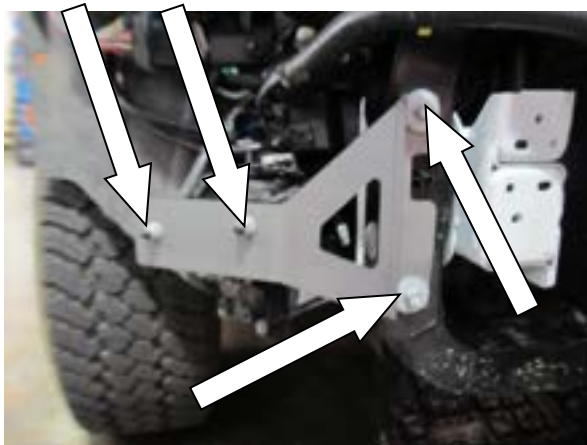

53. If the vehicle is fitted with Quadra-Lift™ suspension, attach the compressor support bracket to the vehicle using the 2 long M8 factory bolts on the vertical section of the cross beam and 2 M8 nyloc nuts to hold the compressor to the bracket.

 M8 - 22 Nm.

## FITTING PROCEDURE



54. Attach the chassis mount braces to the bottom face of the chassis rails using 2 x M10 SEMS bolts in each side. Leave loose at this stage.



55. Attach the mount brackets to the chassis ends using 2 x M8 x 25 hex bolts, M8 spring washers and flat washers in each side. Leave loose at this stage.

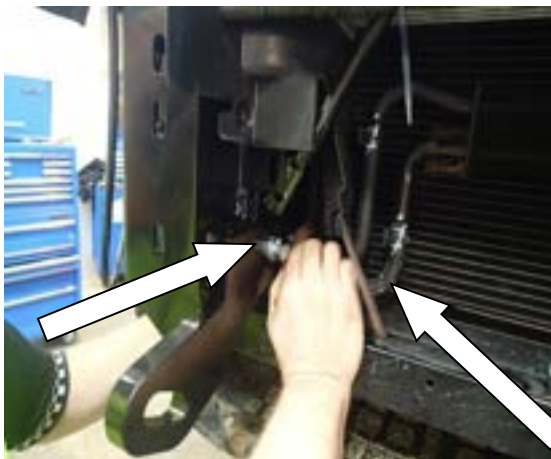

56. Attach the mount brackets to the mount braces using M12 x 65 hex bolts, spring washers, flat washers and flange nuts (x 2 per side) through the side holes and M12 x 40 hex bolts, spring washers, flat washers and flange nuts through the bottom front hole. Leave loose at this stage.
57. On each side, pull the braces as close to the mount bracket as possible and tighten the bolts into the chassis followed by the front bolt followed by the side bolts to the above specified torque.

 M12 - 96 Nm.

 M10 - 44 Nm.

## FITTING PROCEDURE



58. Attach the front cross braces to the mount brackets using M8 x 25 hex bolts, spring washers, flat washers and flange nuts and tighten to the specified torque.

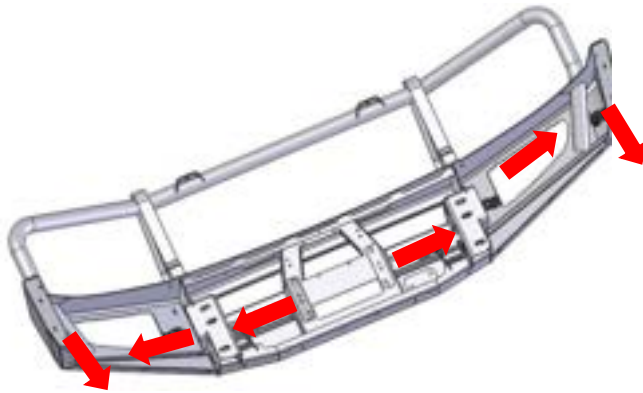
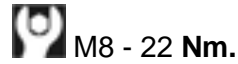

***If fitting parking sensors continue from here. If not proceed to step 68.***

59. Carefully remove the parking sensor loom from the bumper and set aside. Carefully remove the parking sensors from the loom ensuring you have all of the clear rubber grommets that fit between the sensors and the bumper holes.

***Note: When fitting parking sensors to the bar it is important that they are installed in the correct orientation. The arrows to the left show the direction the plug end of the sensors should face.***

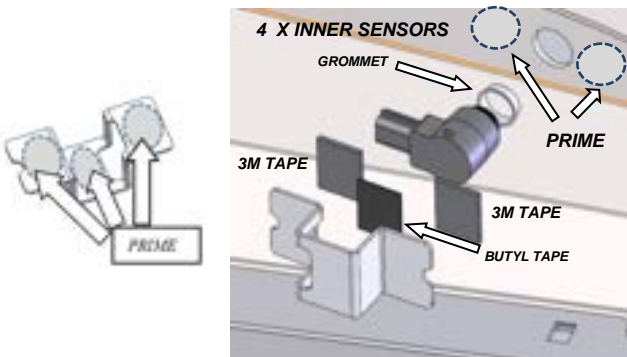

For each parking sensor:

60. Ensure both the parking sensor bracket and mating area of the bull bar are thoroughly cleaned with soap and water and completely dried off. Check park sensor hole size on the bull bar and remove any material causing hole to be smaller than 18.3mm.

61. Using the priming pen supplied, prime the mating faces of both the bracket and the bar.

62. Remove the backing tape from one side of the double sided tape pads (6781437 and 6781427) and apply to each of the mating faces of the bracket. Ensure the configuration in the picture on the left is used.

63. Remove the remaining tape pads from the Butyl tape (6781427). Ensure the clear rubber grommet remains in place, press the parking sensor into the bracket facing the correct direction.

64. Remove the remaining backing 3M tape (6781437) pads. Carefully orientating the parking sensor to sit centred in the hole in the bull bar. Attach the bracket to the bar as shown in the picture to the left.

65. Apply pressure to the bracket for at least 60 seconds.

***Note: There are 4 x brackets with flat mounting surfaces. These are for the 4 inner most sensors. The 2 x bent brackets are for the wing corners.***

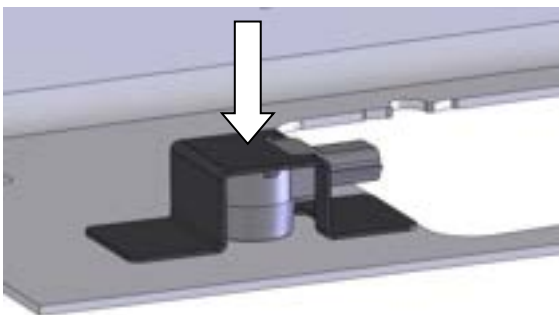
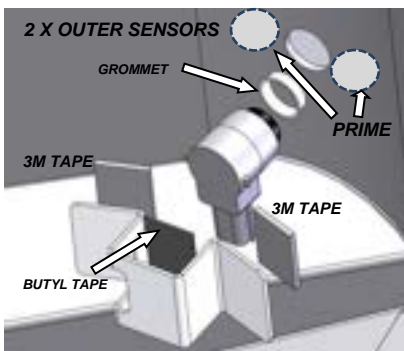

## FITTING PROCEDURE

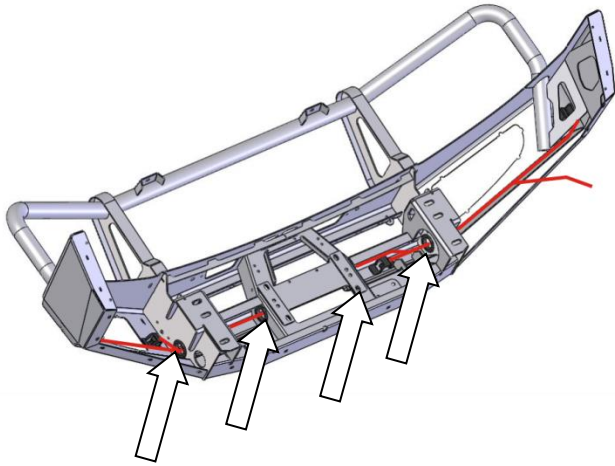

66. Fit 4 x rubber grommets to the holes on the inside of the bar.
67. Route the parking sensor loom starting at the left most sensor moving to the right hand side.

### CAUTION:

- **HARNESS TO PARK SENSORS MUST NOT BE UNDER TENSION.**
- **SENSORS MUST BE POSITIONED ACCURATELY TO HOLES IN BULL BAR (SENSORS NOT ALLIGNED MAY CAUSE MALFUNCTION)**

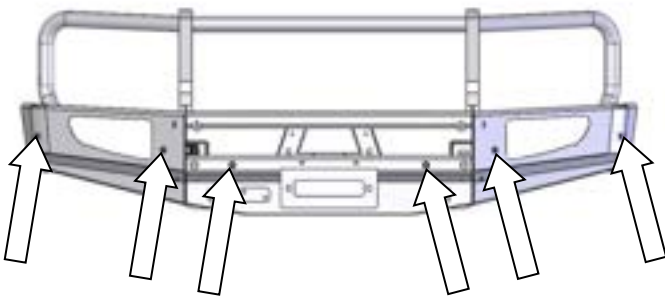

68. If not fitting parking sensors to the bar, fit the 6 x plastic plugs to the bar into the parking sensor holes.

### Impact absorber fitment (step 69)

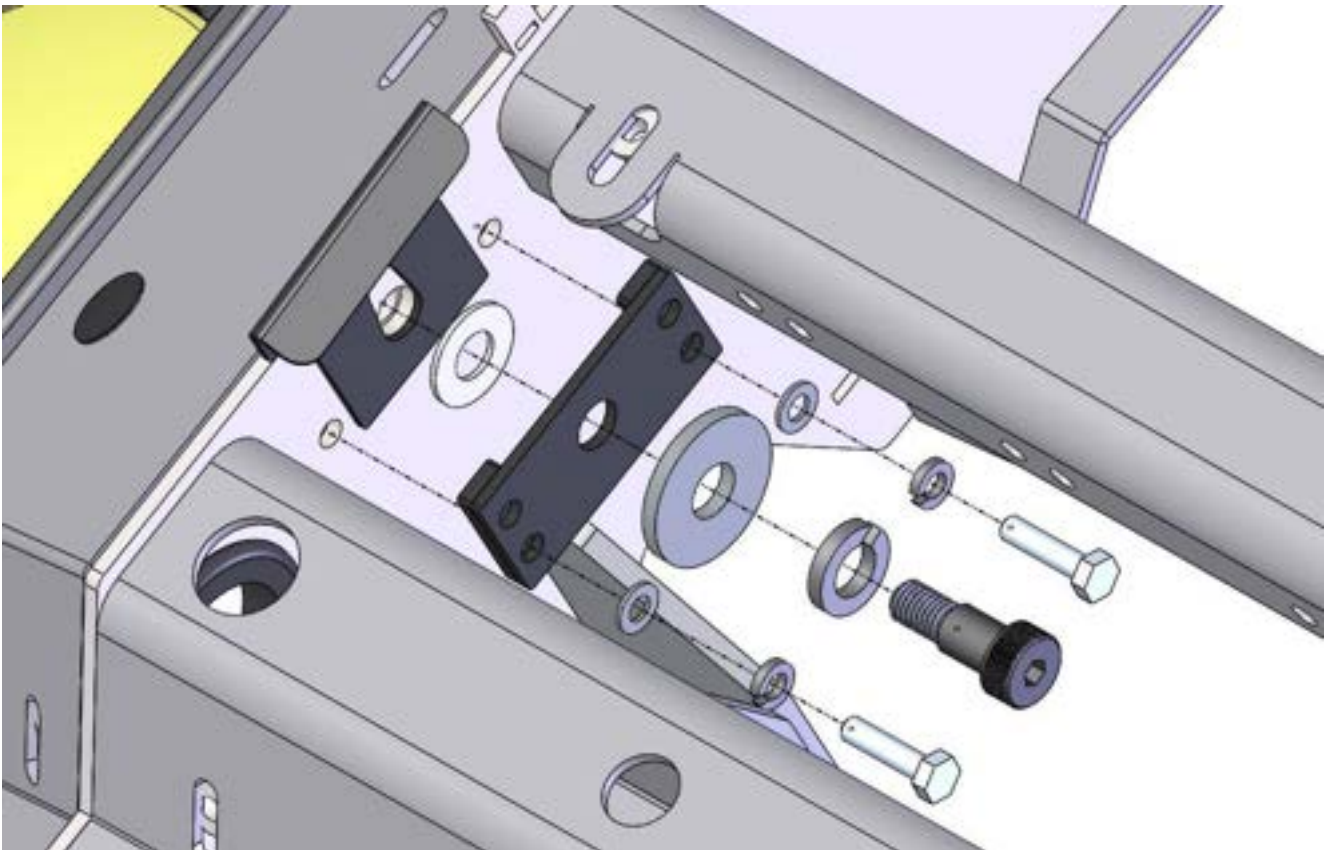

## FITTING PROCEDURE

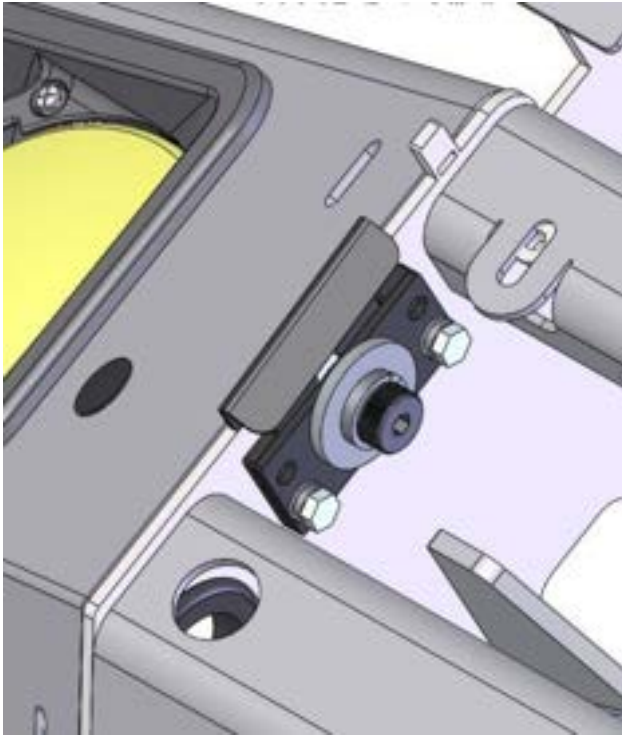

69. Beginning with the right hand side of the vehicle, assemble the impact absorber as per the exploded view diagram shown on page 14 including 2 x M6 flange nuts and 1 x M10 flange nuts hidden in the view. Please see the component list at the start of these instructions for the list of fasteners required. The assembled item should resemble the picture to the left.
70. Once assembled, tighten all fasteners to the specified torque.

 M10 - 44 Nm.

 M6 - 9 Nm.

**Warning: If the fasteners are not tightened to the correct torque setting the impact absorber may not perform correctly in the event of a collision.**

71. Repeat on the left hand side.



72. Assemble and install combination light surrounds (p/n 3163015) as per instructions no. 3786421 supplied with surround kit. Note: Optional fog lamps can be installed at this point as per fitting instruction no. 3783315 supplied with fog lamp kit no. 6821201.

73. Connect the lamp loom to the small extension loom.

**Caution: Cable tie all cables together and keep all cables clear of sharp edges and moving parts.**



If the vehicle is fitted with adaptive cruise control continue from here using radar kit **3550100**. If not proceed to step 82:

74. Remove the radar sensor from the OEM bracket by twisting the 3 black plastic lugs  $\frac{1}{4}$  turn anti clockwise which will release the sensor from the bracket.
75. Remove the plastic lugs from the ends of the radar sensor mount pins and set aside.
76. Discard the OEM bracket.

## FITTING PROCEDURE



77. Fit the plastic lugs removed about to the radar sensor bracket as shown by inserting the lugs and turning  $\frac{1}{4}$  turn clockwise.

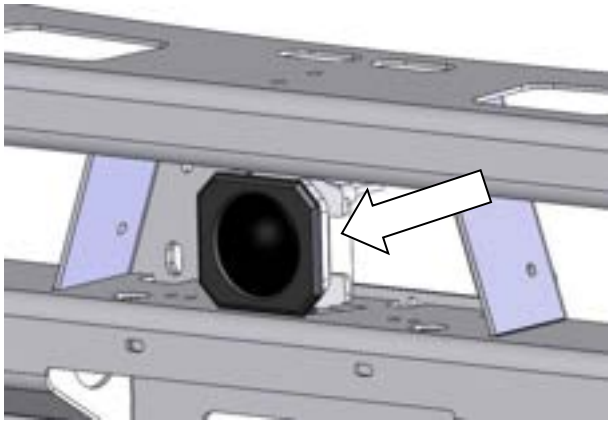

78. From the rear, carefully place the radar sensor into the bar as shown.

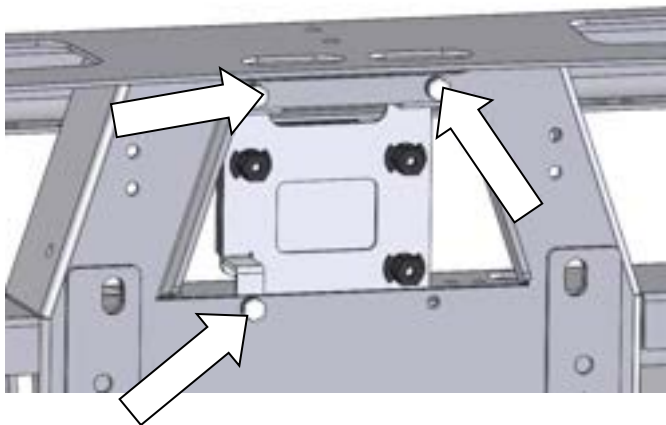

79. Attach the bracket to the bar from the rear as shown using M6 x 20 hex bolts, spring washers, flat washers and flange nuts.

80. Tighten the fasteners to the specified torque.

 M6 - 9 Nm.

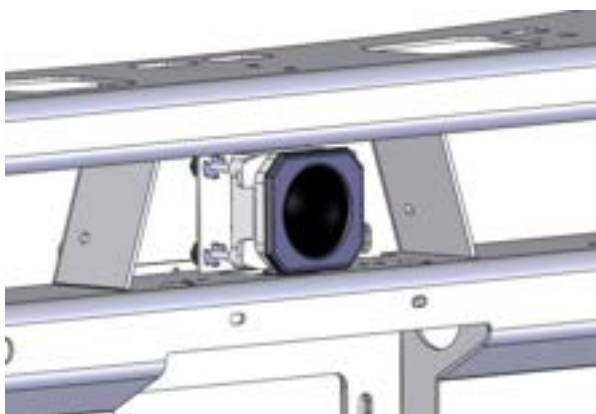

81. Carefully push the radar sensor into the plastic lugs ensuring that they all clip in firmly.



## WINCH FITMENT (if not fitting winch proceed to step 91)

***This bull bar has been designed to fit a range of Warn, Magnum, Bushranger and Smittybilt winches up to a capacity of 10000lbs capacity. It is important that a winch of a greater capacity is not fitted even if it physically fits into the bar. Failure to comply could result in damage to the bar and / or personal injury. Please read and take note of the owner's manuals supplied with your winch before proceeding. The following steps vary depending on which winch you are fitting.***

***In the case of Warn Zeon winches, a supplementary kit (Warn p/n 86695) is required. In the case of Smittybilt supplementary kit 3500580 is required.***

***If fitting synthetic rope supplementary kit 3540060 is required.***

***For ALL winches ARB winch install kit 3540050 is required.***

### 82. Winch Preparation

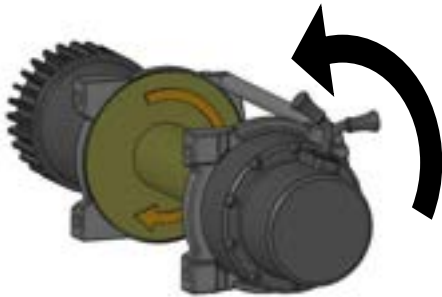

Warn / Magnum /Smittybilt winches: Undo the screws in the gearbox end of the winch. Carefully slide the gearbox away from the winch only until it is able to rotate. Rotate the gear box anti-clockwise 72° and replace screws.

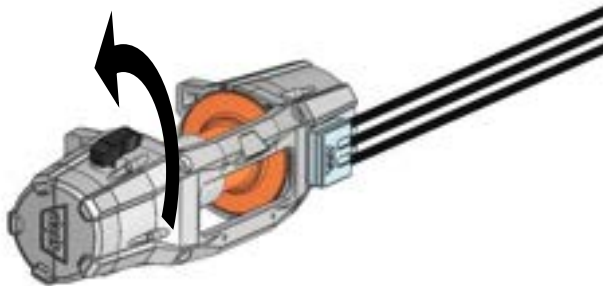

Warn Zeon winches: Undo the screws in the gearbox end of the winch. Carefully slide the gearbox away from the winch only until it is able to rotate. Rotate the gear box anti-clockwise 72° and replace screws.

Remove the control box as per the Zeon control pack relocation kit installation guide.

Install the relocation kit to the winch only. Remove the control pack and remote socket from the control box and set aside.

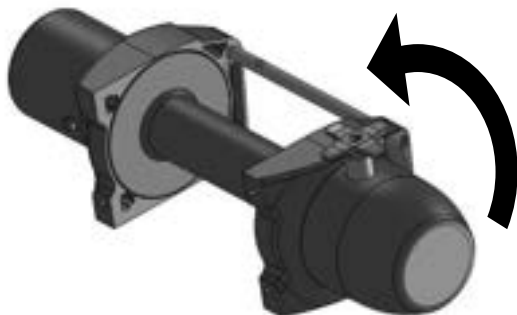

Bushranger winches: Undo the screws in the gearbox end of the winch. Carefully slide the gearbox away from the winch only until it is able to rotate. Rotate the gear box anti-clockwise 90° and replace screws.

Remove the control pack and remote socket from the control box and set aside.

## FITTING PROCEDURE

*If fitting a Bushranger or Zeon winch continue from here. If not continue to install the winch as per fitting instructions 3787989 supplied with kit 3540050. The following pictures show the zeon plug and plug cover. The same steps apply for fitment of Bushranger winches.*

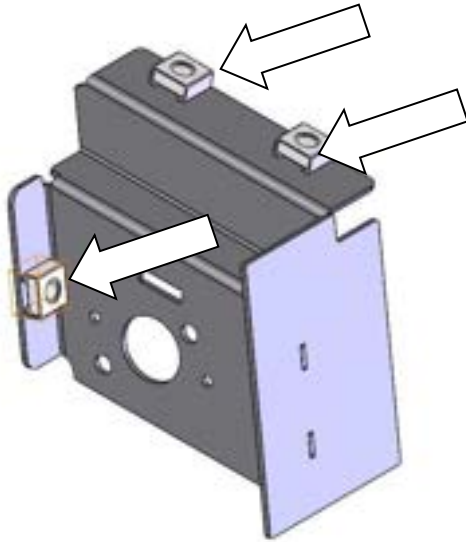

83. Fit M6 cage nuts to the plug mount bracket.

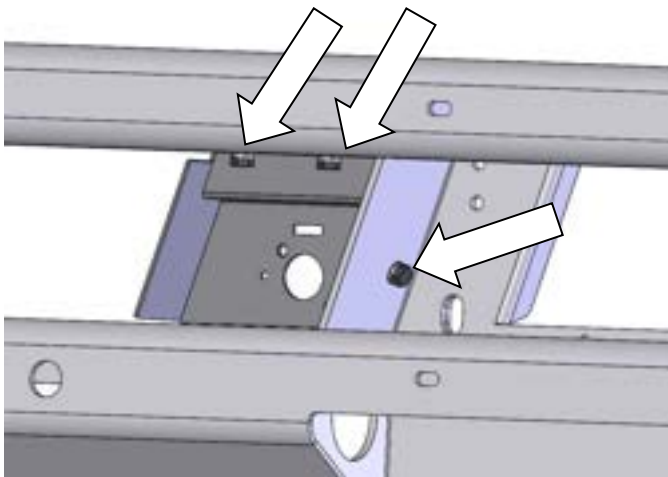

84. Attach the mount bracket to the bar using M6 hex bolts, M6 spring washers and M6 flat washers.

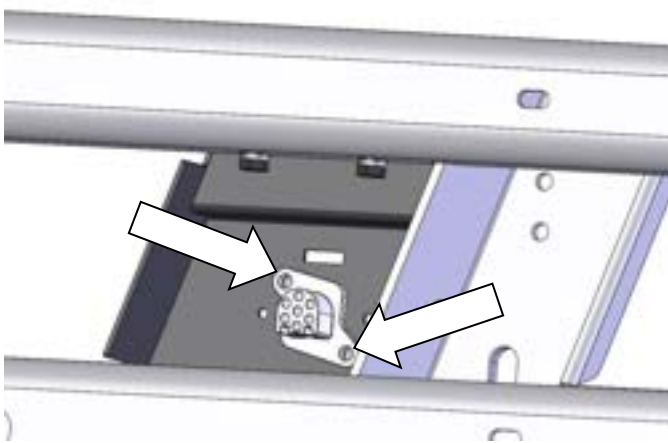

85. Attach the remote socket to the bracket using the screws removed from the factory control box. In the case of Zeon, use the M5 flange nuts supplied with the bar kit.

**Note: 2 sets of holes have been cut to match the 2 different sockets.**

## FITTING PROCEDURE

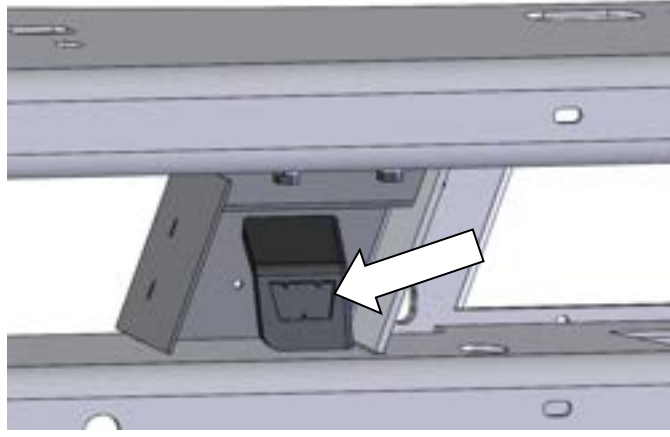

86. Attach the socket cover to the socket.

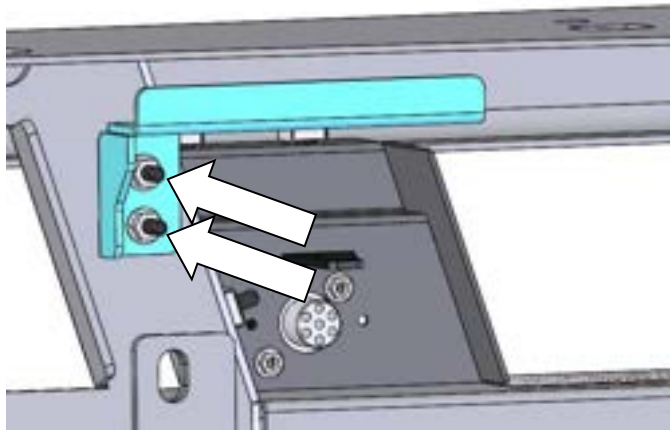

87. Attach the control pack mount bracket to the bar as shown using M6 hex bolts, M6 spring washers and M6 flat washers and M6 flange nuts.

 M6 - 9 Nm.

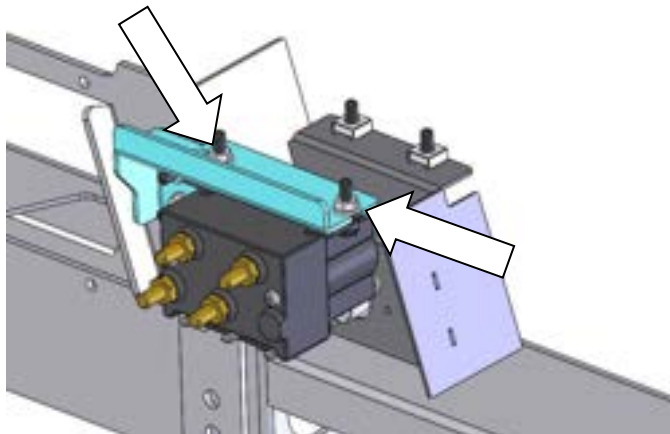

88. Attach the control pack to the bracket as shown using M6 hex bolts, M6 spring washers and M6 flat washers and M6 flange nuts.

89. Connect the wires from the socket to the control pack.

90. Fit the winch to the bar as per fitting instructions supplied with kits 3540050, 3500580 and 3540600 as required.

 M6 - 9 Nm.

## FITTING PROCEDURE



91. If fitting a winch and a radar sensor attach the folding license plate bracket supplied in kit 3540050 to the lower pan using M6 SS button head screws, M6 SS flat washers and M6 flange nuts.

Or



92. If fitting a winch only attach the folding license plate bracket supplied in kit 3540050 to the upper pan using M6 SS button head screws, M6 SS flat washers and M6 flange nuts.

Or

93. If no winch is fitted attach the license plate directly to the upper pan using M6 SS button head screws, M6 SS flat washers and M6 flange nuts.



94. With the assistance of another person or a lifting device, lift the bar onto the car so that the mount faces of the bar align with the faces of the mount brackets.

95. Attach the bar to the mounts using M12 hex bolts, M12 spring washers, brace plates and M12 flange nuts. Leave loose at this stage

**Note: Access to the bolts can be made through the gap between the pans and the holes cut in the lower pan.**



96. Adjust the bar so that it is central to the vehicle and has an even gap of between 8-14mm between the rear edge of the bar and the vehicles bumper.

**Note: Fore / Aft position and angular adjustment can be made by placing the required quantity of packer plates between the bar and the mount brackets.**

When you are happy with the position of the bar, tighten the fasteners to the required torque setting.

 M12 - 96 Nm.

## FITTING PROCEDURE

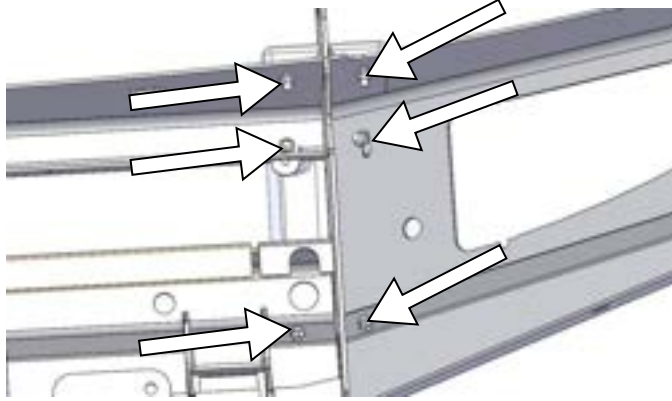

97. Attach the buffers to the bar using M6 flange nuts.

 M6 - 4 Nm.

**Warning: Do not over tighten the nuts or you risk pulling the studs from the buffers.**

98. Connect the indicator / clearance lights to the looms installed earlier as well as the parking sensors, radar, fog lights and winch if fitted.

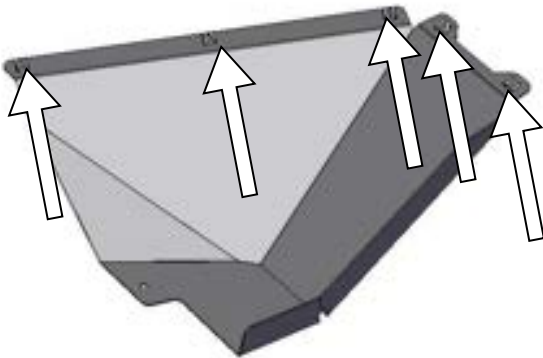

99. Add M6 cage nuts into the top surface of the RH and LH under wing panels as shown.

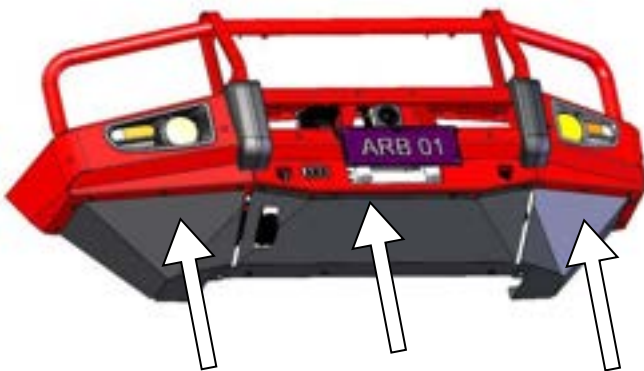

100. Fit the centre panel to the bar and the vehicle (sandwiching the OEM under panel to the cross member) using M6 hex bolts, M6 spring washers and M6 flat washers.

101. Fit the under wing panels to the bar using M6 hex bolts, M6 spring washers and M6 flat washers.

102. Attach the under wing panels to the centre panel using M8 hex bolts, M8 spring washers M8 flat washers and M8 flange nuts.

 M6 - 9 Nm.

 M8 - 22 Nm.



103. On each side of the vehicle, hold the inner guard against the wing and under wing panel.

104. Using a marker or paint pen, mark a line along the bottom edge of the under wing panel on the inner guard.

105. Using a saw or sharp knife, carefully cut along the marked line and remove the bottom section of the inner guard.

**Warning: Take care when cutting the inner guards to cut away from yourself to prevent injury.**

## FITTING PROCEDURE



106. On the inner guard of each side of the vehicle, mark a line as shown just below the top edge of the bulbar, in board approximately 25mm and just above the bottom edge of the trimmed bumper bar.
107. Using a saw or sharp knife, carefully cut along the marked line and remove the square shaped piece.
108. Tuck the inner guard in behind the bull bar wing and under wing panel.

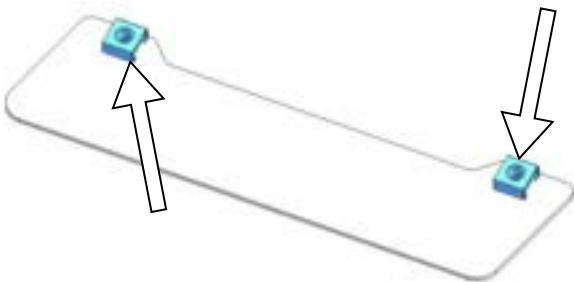

109. Place M6 cage nuts into each of the inner guard retention plates.

**Note: RH side shown, LH side opposite.**

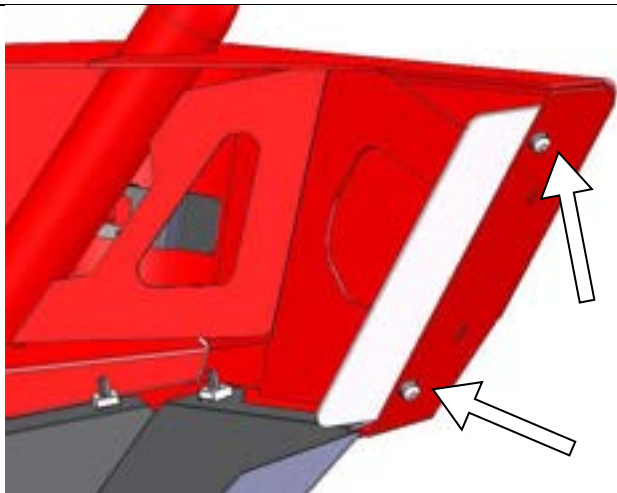

110. Attach the inner guard retention plates to the bulbar as shown using M6 button head screws, M6 spring washers and M6 flat washers.

**Note: Both stainless steel and black hardware have been supplied to fit the inner guard retention plates. For darker coloured bars, please use the black hardware and stainless steel for light coloured bars.**

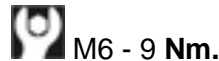

111. Place the tow warning label onto the top surface of the lower pan as shown.

**Warning: This label must be fitted and cannot be removed.**

## **FITTING PROCEDURE**

### **ONCE BAR IS FITTED:**

- **Ensure all bolts are tensioned correctly.**
- **All wiring is clear of sharp edges or moving surfaces and secured properly.**
- **Piping is secured well away from sharp or moving components.**
- **Check operation of winch, if fitted.**
- **Check all wiring and connections to turn signal lamps, sensors, headlamp washers etc. are functioning correctly.**
- **Misalignment of parking sensor to hole in bull bar may cause malfunction, if fitted.**
- **Test operation of parking sensors after fitment, if fitted.**

### **Note:**

**If parking sensors are fitted, do not add any accessories to the Bull Bar on or around the sensors, this may affect the function of the sensors.**

### **Sensors may not function well under the following conditions;**

- **After the vehicle, has been sitting out in hot or cold weather.**
- **When the system is affected by electrical equipment or devices generating an ultrasonic wave.**
- **When operating in bad weather.**

## FITTED PRODUCT

