



FITTING INSTRUCTIONS

Part Number: **3462050K, 3462060K**
Product Description: **SUMMIT BAR CHEV COLORADO**
Suited to vehicle/s: **Chevrolet Colorado 150N (Excludes 2WD BASE Model), Chevrolet ZR2 150N**
Optional Fitting Kit: **Fog Lamps**
3500910 – LED Fog Light Kit (LH&RH Lights) (Requires 3500520 Loom)
3500520 - ARB AUX LED Fog Light Loom
3500680 - Fog Lamp Housing Clear Lens Kit

Winch Install Kit
3500930 - SUMMIT BAR WINCH INSTALL KIT USA
3500860 – SUMMIT BAR WINCH INSTALL KIT USA NO NP BRKT

WARNING

REGARDING VEHICLES EQUIPPED WITH SRS AIRBAG:

When installed in accordance with these instructions, the front protection bar does not affect operation of the SRS airbag.

ALSO, NOTE THE FOLLOWING:

- ◆ This product must be installed exactly as per these instructions using only the hardware supplied.
- ◆ In the event of damage to any component, contact your nearest authorised ARB stockist. Repairs or modifications to the impact absorption system must not be attempted.
- ◆ Do not use this product for any vehicle make or model, other than those specified by ARB.
- ◆ Do not remove labels from this bull bar.
- ◆ This product or its fixing must not be modified in any way.
- ◆ The installation of this product may require the use of specialized tools and/or techniques
- ◆ It is recommended that this product is only installed by trained personnel
- ◆ These instructions are correct as at the publication date. ARB Corporation Ltd. cannot be held responsible for the impact of any changes subsequently made by the vehicle manufacturer
- ◆ During installation, it is the duty of the installer to check correct operation/clearances of all components
- ◆ Work safely at all times
- ◆ Unless otherwise instructed, tighten fasteners to specified torque

ARB 4x4 ACCESSORIES

Corporate Head Office

42-44 Garden St
Kilsyth, Victoria
AUSTRALIA 3137

Tel: +61 (3) 9761 6622
Fax: +61 (3) 9761 6807

Australian enquiries
North & South American enquiries
Other international enquiries

sales@arb.com.au
sales@arbusa.com
exports@arb.com.au

www.arb.com.au

GENERAL CARE AND MAINTENANCE

By choosing an ARB Bar, you have bought a product that is one of the most sought after 4WD products in the world. Your bar is a properly engineered, reliable, quality accessory that represents excellent value. To keep your bar in original condition it is important to care and maintain it following these recommendations:



- Prior to exposure to the weather your bar should be treated to a Carnauba based polish on all exposed surfaces. It is recommended that this is performed on a six monthly basis or following exposure to salt, mud, sand or other contaminants.
- As part of any Pre Trip Preparation, or on an annual basis, it is recommended that a thorough visual inspection of the bar is carried out, making sure that all bolts and other components are torqued to the correct specification. Also check that all wiring sheaths, connectors, and fittings are free of damage. Replace any components as necessary. This service can be performed by your local authorized ARB Stockist.

FITTING REQUIREMENTS

REQUIRED TOOLS FOR FITMENT OF PRODUCT:

Metric Socket Set	Metric Wrench Set
Phillips Head Screwdriver (Short and Long Length)	Air Saw or Jigsaw
Short Body Power Drill 13mm (1/2") capacity	10.5mm (25/64") drill bits
Torque Wrench (9-102Nm)	Marking pen
Half round file	Soft Hammer
Torx Bit Set	Metric Hex Set
Wide masking tape	Stanley knife and Multitool
Small Spirit Level	Tape Measure or Ruler
Right-angled Drill	Black Rust Preventative Pain

HAVE AVAILABLE THESE SAFETY ITEMS WHEN FITTING PRODUCT:

Protective eyewear 	Hearing protection 
--	--

NOTE: 'WARNING' notes in the fitting procedure relate to OHS situations, where to avoid a procedure be employed. If these notes and warnings are not heeded, injury may result.

FASTENER TORQUE SETTINGS:

SIZE	Torque Nm	Torque lb-ft
M6	9	7
M8	22	16
M10	44	32
M12	77	57

PARTS LISTING

APPLICATION.	PART NO.	QTY	DESCRIPTION
Mount Brackets To Chassis	3750091L	1	BRACKET MOUNT WELDMENT LEFT
	3750091R	1	BRACKET MOUNT WELDMENT RIGHT
	3194983	2	PLATE NUT FRAME END
	4584361	12	WASHER M10x25x4 HV300 TZP480
	4584363	4	WASHER M12x26x4 HV300 TZP480
	6151097	4	BOLT HXHD M12 X 1.25 X 50 CL8.8 ZP
	6151128	4	NUT FLANGE M6 x 1.0 ZP
	6151204	14	BOLT M10 x 1.5 x 35 Gd 8.8 ZP
	6151304	6	NUT CAGED M10 3.3-4.7
	6151321	8	NUT FLANGE M10 x 1.5 ZP
	6151480	4	BOLT M12 x 1.75 x 100 Gd 10.9 ZP
	6151270	4	BOLT HXHD M6x1.0x40 PC8.8 ZP
	6250036	6	SPACER MOUNT COLORADO US
Brace Assembly	3750144L	1	BRACKET MOUNT STIFFENER LEFT
	3750144R	1	BRACKET MOUNT STIFFENER RIGHT
	3195011	2	PLATE BUSHING M12 x 43 OD
	3195012	4	PLATE TOW HOOK SPACER
	3195027	2	PLATE FRAME SPACER ZINC
	4584363	8	WASHER M12x26x4 HV300 TZP480
	4721892	2	TUBE CRUSH 12.6 x 17 x 26.5
	6151428	6	NUT FLANGE M12 X 1.75 ZP
	6151688	6	BOLT M12 x 1.75 x 100 Gd 10.9 ZP
Stone Tray to Bull Bar	6523169	1	PANEL CENTER STONE SHIELD
	6151304	4	NUT CAGED M10 3.3-4.7
	6151204	4	BOLT M10 x 1.5 x 35 Gd 8.8 ZP
	4581083	4	WASHER FLAT, M10 x 21 x 2 ZP
Fit Lights and Mouldings	3500880	1	GRILLE SPLIT PAN KIT
	6821116	4	GROMMET NYLON SNAP IN TYPE
	6821287	1	LAMP LED INDICATOR CLEARANCE
	5100200	1	BUFF KIT 2PCE FRONT SECTION
	5100210	1	BUFF KIT 2PCE REAR UPRIGHT BAR
	3163082	1	KIT SURROUND ARB FOGLIGHT
Number Plate To Bull Bar	3750095	1	BRACKET US LICENSE PLATE FIXED
	4581082	3	WASHER FLAT, M6 x 19 x 1.6 BZ
	6151128	3	NUT FLANGE M6 x 1.0 ZP
	6151384	2	SCREW ST PHDCOL PH 5.2 X 16 TBZP480
	6821189	2	GROMMET RND FC 1500 080 090
	6151443	3	SCREW BTN HD M6 x 20 BZ
Wing Inner Panels	6523168L	1	PANEL WING COLORADO US LHS
	6523168R	1	PANEL WING COLORADO US RHS
	4581082	10	WASHER FLAT, M6 x 19 x 1.6 BZ
	6151443	10	SCREW BTN HD M6 x 20 BZ
	6151526	10	NUT CAGED M6 1.8-2.7x9.5 480BLK
	4581083	2	WASHER FLAT, M10 x 21 x 2 ZP
Fit Winch Cover Panel	6523216/6523170	1	PANEL WINCH COVER
	6151443	4	SCREW BTN HD M6 x 20 BZ
	6151128	4	FLANGE NUT M6 x 1.0 ZP
	4581082	4	WASHER FLAT, M6 x 19 x 1.6 BZ
Miscellaneous	3789667	1	TEMPLATE BUMPER COLORADO US
	6191030	1	PINCH WELD 520MM

PREPARATION OF VEHICLE



1. Remove screws holding license plate. Set plate aside for reassembly later.
2. Remove the (6) Torx head screws from the bottom and up the side of the inner fender well. Repeat on the opposite side.



3. Pull back the felt, fender liner to expose the (3) hex head screws as shown in the diagram. Remove these screws on both sides.



4. Open the hood. Remove the (6) torx head screws retaining the top of the top grille section.



5. On the underside of the vehicle there is a plastic protection panel. Remove the (4) hex head screws retaining this panel. Set panel aside for re-installation later.
6. Remove the (2) smaller hex head screws retaining the bumper fascia by the tabs shown in the adjacent diagram.

Note: For clarity, picture shown is looking at the back of the bumper once removed.



7. Looking directly at the grille there are (2) hex head screws through holes as shown in the diagram. Remove these screws.

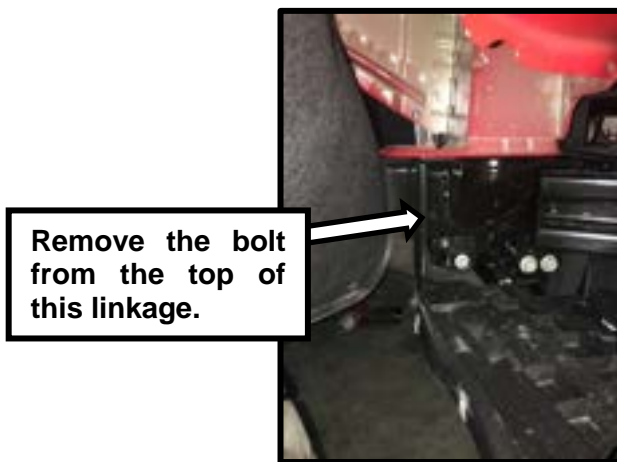

8. Pull back the fender liner enough to uncover the vertical linkage shown in the diagram. Remove the (1) hex head screw attaching this linkage to the body of the vehicle.



9. With the fender liner pulled back, if your truck is fitted with fog lights, remove the lights wire harness by pushing the tab and pulling away.



10. Also behind the fender liner, there is a push tab as shown in the diagram. Push in the tab and push to remove this tab on both sides.

11. At this point the bumper is free from the vehicle. Push down near the fenders to remove the plastic pilots in this area and pull the bumper away from the vehicle. Set aside in a safe place.

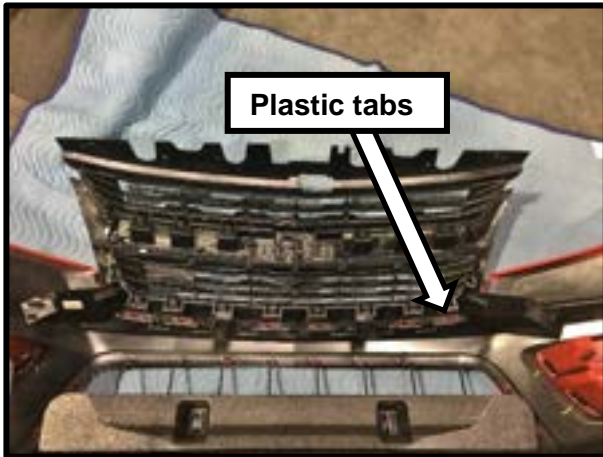

12. With the bumper off, remove the top grille section from the lower fascia by depressing the tabs shown in the diagram and pushing them out.



13. Move the air deflector by removing the (3) pop rivets attaching it to the grille support, the (2) pop rivets attaching it to the crush beam, and depressing the tabs attaching it to the grille support.

Note: This plastic part will not be re-installed later.



14. Remove the stock crush beam from the frame rails by removing the (4) hex screws shown in the diagram.

15. Remove the (2) covers from the tow hooks.

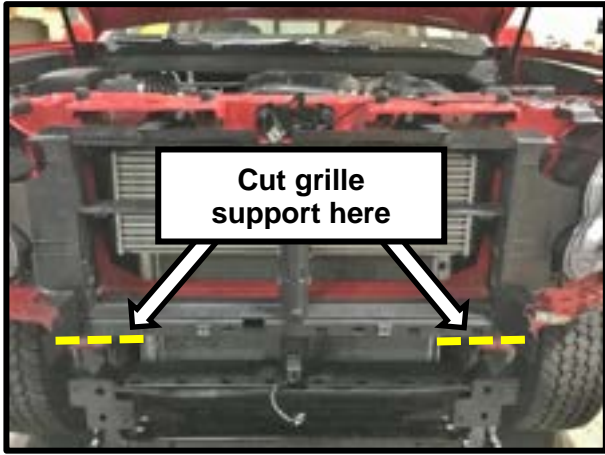

16. Cut the grille support as shown in the diagram. Be sure to keep the ambient air temperature sensor perch in tact during this cutting operation.

17. Remove the bottom radiator shroud by removing the (2) pop rivets attaching it to the body of the vehicle and depressing the tabs attaching it to the radiator moulding.



Warning: Cutting operations can result in flying debris, safety glasses should be worn.



18. Re-attach the top grille section to the vehicle. (Standard Colorado shown, ZR2 is the same)



19. Mark the bumper fascia as shown in the diagram using the supplied template.

Note: The top of the cutting template lines up with the radius just under the headlight, not the edge of the plastic that goes under the headlights.



20. Extend the line on the outside straight across the fender flange as shown in the diagram.

Note: You should be able to preserve the 2nd captured nut from the top.



Apply masking tape to the inside of your cut line.

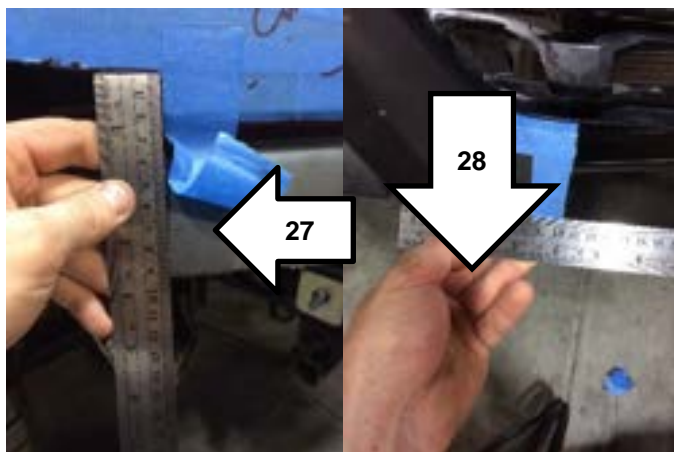
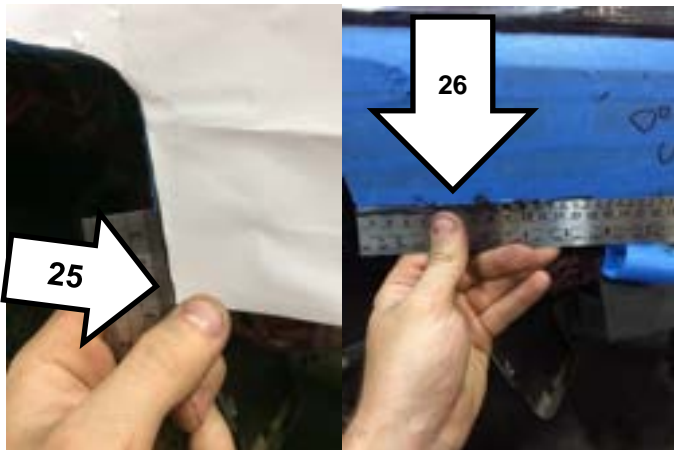

If installing on a standard Colorado, use instructions 21-24. If installing on a ZR2, use instructions 25-28.

Standard Colorado only

21. Extend the line on the inside 210mm as shown.
22. From this line go down 50mm.
23. From this line go 385mm inwards following the crease in the bumper fascia.
24. From this line go up to the top. Make sure that you have at least (1) tab on each side to re-connect to the center grille section. Refer to next image.

ZR2 Installations only

25. Extend the line on the inside 40mm as shown.
26. From this point, go 140mm inboard.
27. From this line go down 100mm.
28. From this line go 100mm from the edge of the grille surround.
29. From this line go up to the top. Make sure that you have at least (1) tab on each side to re-connect to the center grille section. Refer to next image.
30. When you have your line complete, cover the inside of the line with masking tape to protect the side you're keeping during the cut.

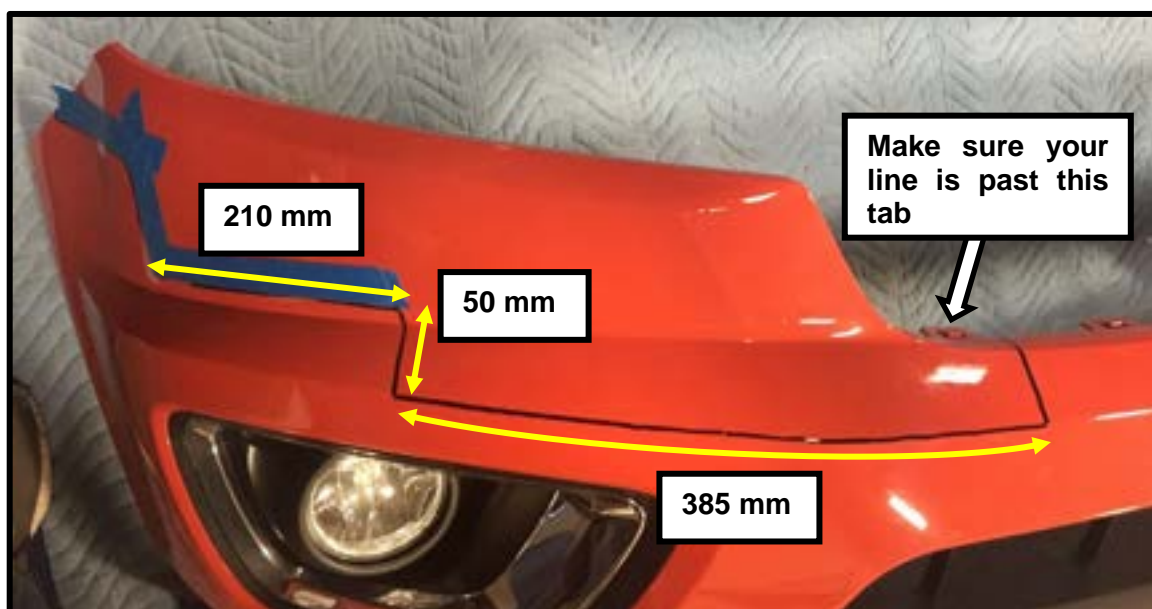

Make sure your line is past this tab

210 mm

50 mm

385 mm



Grind the black plastic in this area until pinch weld can fit over

31. Using an air saw or jig saw, carefully cut the bumper fascia along the cut line.
32. Using a grinder clean up the edge close to the fender with a grinder.



33. Re-install the cut fascia pieces back onto the vehicle by inserting the tabs into the center grille and re-installing the hex screws removed earlier in the fender wells.
34. Mask up the fender/facia as shown.
35. Prepare flange for paint.



36. Spray paint the flange black as shown.



37. Cut the supplied pinch weld so that it covers the exposed area as shown in the photo.

MOUNT INSTALLATION

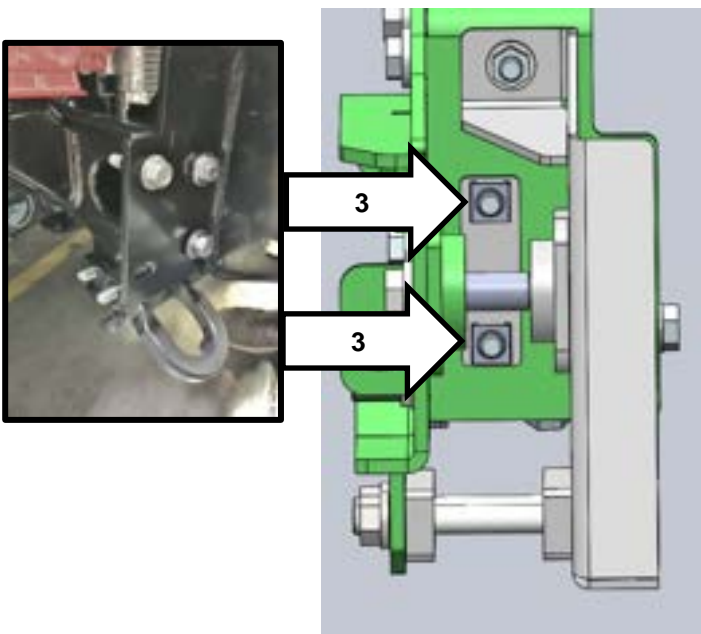

1. If you have OE tow hooks installed on your vehicle, remove the (2) hex bolts and nuts securing them to the frame and set aside the tow hooks.
2. Starting on the right side, take the bigger, main mount bracket and slide over the end flange of the frame. Secure to the end flange (hand tight only) of the frame using the (2) OE flange bolts removed earlier.
3. Install the (2) M10 cage nuts into the rectangular nut plates.
4. Feed the nut plate into place from the hole in the outside of the frame. Hand tighten the corresponding M10 x 35 hex bolts with flat washers into the nut plate as shown in the diagram.



5. If you have OE tow hooks, place the hook back in position between the mount plate and the chassis. Using the supplied M12 x 100 hex bolts with a flat washer hang the tow hooks into position. If you do not have, or do not wish to re-install the tow hooks, use the provided spacers (2) on each side to take up the space.
6. Insert another M12 x 100 bolt with flat washer through the hole in the mount through the chassis.



7. On the other end of the bolt through the chassis, hang the following parts in order from first to last:
 - 17 mm OD x 26.5 mm Bushing
 - 43 mm OD x 10.0 mm Bushing
 - 65 mm Square Plate

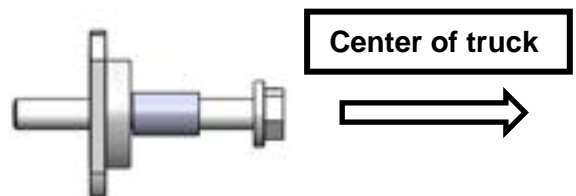



Back out OE bolt

8. Place the Mount Stiffener Bracket into place on the outside of the chassis, aligning it with the (3) open ended M12 bolts. Using M12 flange hex nuts, hand tighten the bracket in place. You will have to back out the outside OE bolt to slide this bracket into place.
9. At the (2) mating locations between the Mount Stiffener Bracket and the Mount, secure using M10 x 35 hex bolt, flat washer, and flange hex nut sets. Be sure to feed the bolts in from the front.
10. Tighten each fastener to the recommended value.

 M12 - 77 Nm.

 M10 - 44 Nm.

PREPARING BAR FOR INSTALLATION

Note: If fitting a winch proceed from here using fitting instructions 3789680 supplied with 3500930 winch install kit. Once the winch is fitted please continue to step 4 of this section.

Note: The computer-generated diagrams in this section are a generic representative. Some of the graphical details in these diagrams may differ from your Bull Bar.

1. Slide the winch cover panel from the bottom up until it is level with the top face of the bar.
2. Fit the winch cover panel to the bar using 4 x M6 x 20 hex bolts, flat washers and flange nuts.

Warning: Be careful not to scratch the finish of the winch cover panel.

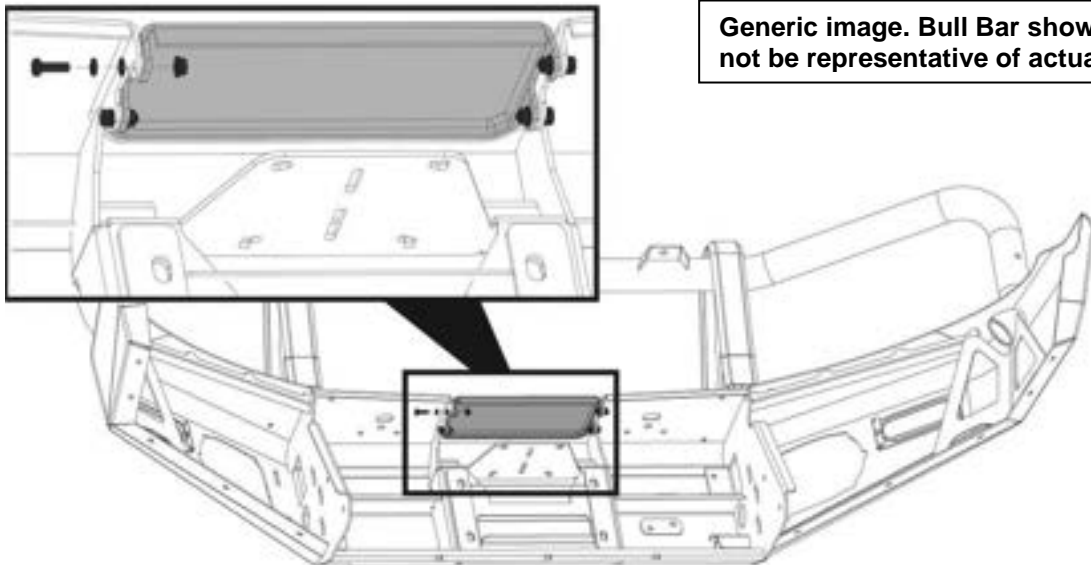

Generic image. Bull Bar shown may not be representative of actual product.

3. Fit the number plate bracket to the top face of the lower-centre pan on the bar using 3 x M6 x 20 hex bolts, washers, flat washers and flange nuts.

Note: If you are fitting a winch, fit the folding number plate bracket supplied in winch install kit "3500930 WINCH INSTALL KIT" – See fitting instructions 3789680

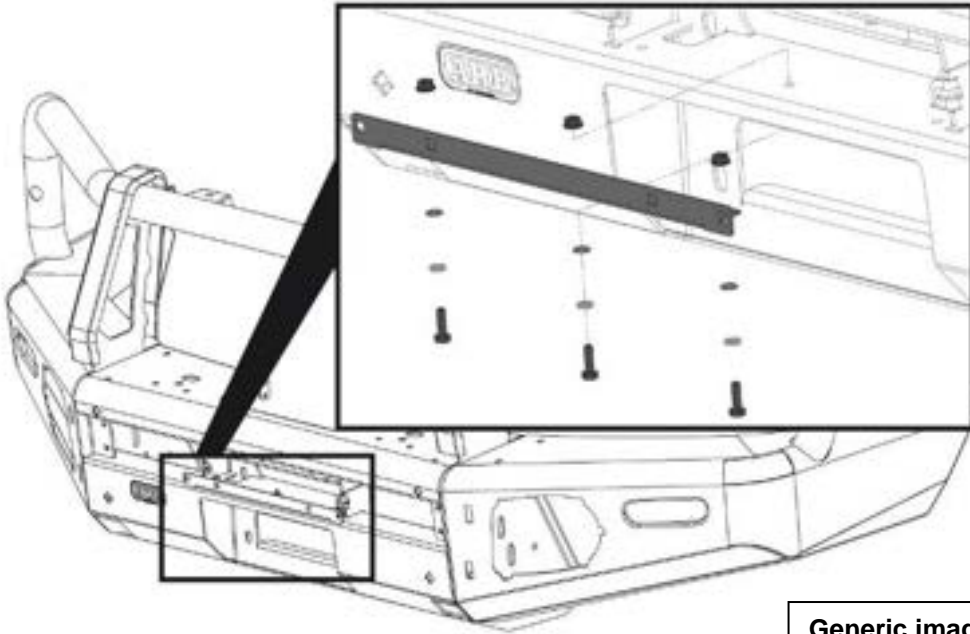

Generic image. Bull Bar shown may not be representative of actual product.

Note: The following steps show the fitment of the plastic moulded parts. The mouldings are supplied in kits along with all fasteners required for fitment. It is important that the fasteners supplied with each kit are only used for the mouldings from the same kit. The kits included in this bar kit are as follows:

- Layout the contents of each of the following kits ensuring the contents are kept separate from each other.

Kit No.	Description
5100200	BUFF KIT 2PCE FRONT SECTION
5100210	BUFF KIT 2PCE REAR UPRIGHT BAR
3500880	SPLIT PAN MESH KIT
3163082	FOG SURROUND KIT

- Mark the grille panel to be cut at the 890mm marks at each end on the back face.

Note: When marked, double check the measurement with a measuring tool.

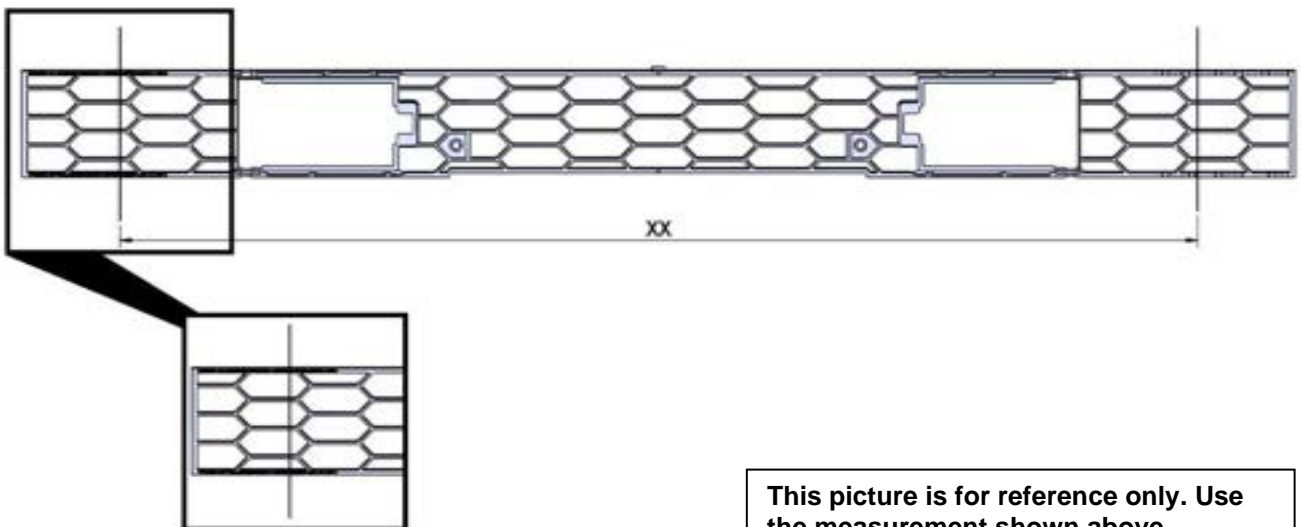

This picture is for reference only. Use the measurement shown above.

6. Use a hacksaw or similar cutting tool to carefully cut the grille panel at the positions marked in the step above.
7. Discard the off cuts and clean up the cut edges using a file or sandpaper.

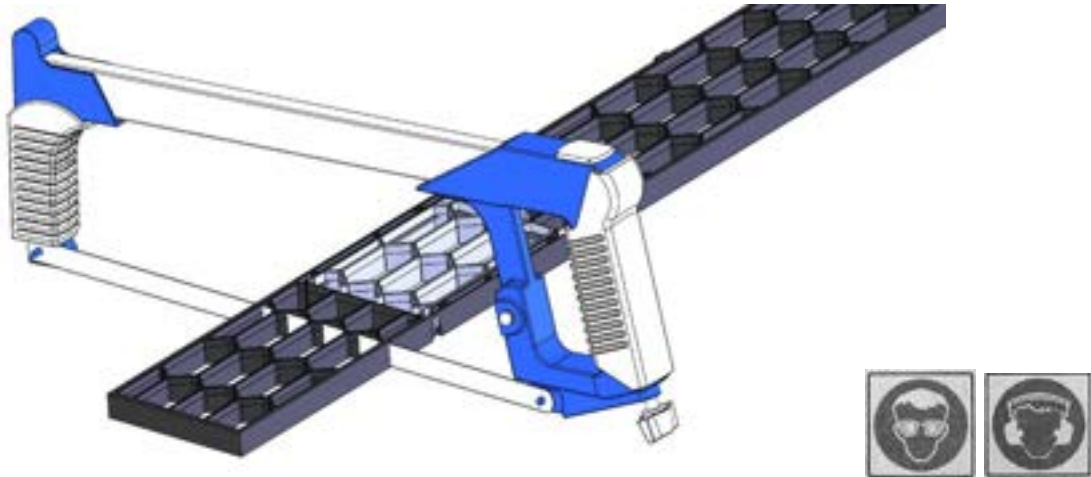

8. Insert the 6 x plastic grommets into the 6 square holes in the front face of the bar.
9. Insert the grille into the bar so that the hatches open outward (facing the front of the bar).
10. Attach the grille to the centre of the bar using the short screws into the grommets fitted above.
11. Attach the ends of the grille to the bar using the longer screws, through the clamp plates into the remaining grommets.

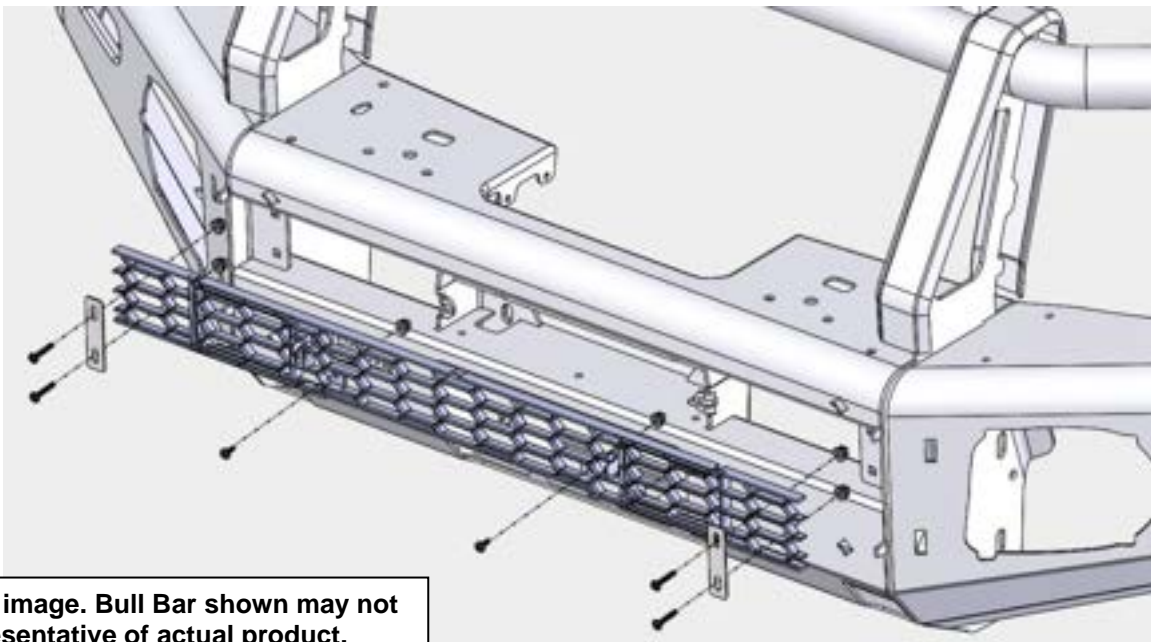

12. Fit the rubber intersection mouldings to the base of each upright cover strap.

Generic image. Bull Bar shown may not be representative of actual product.

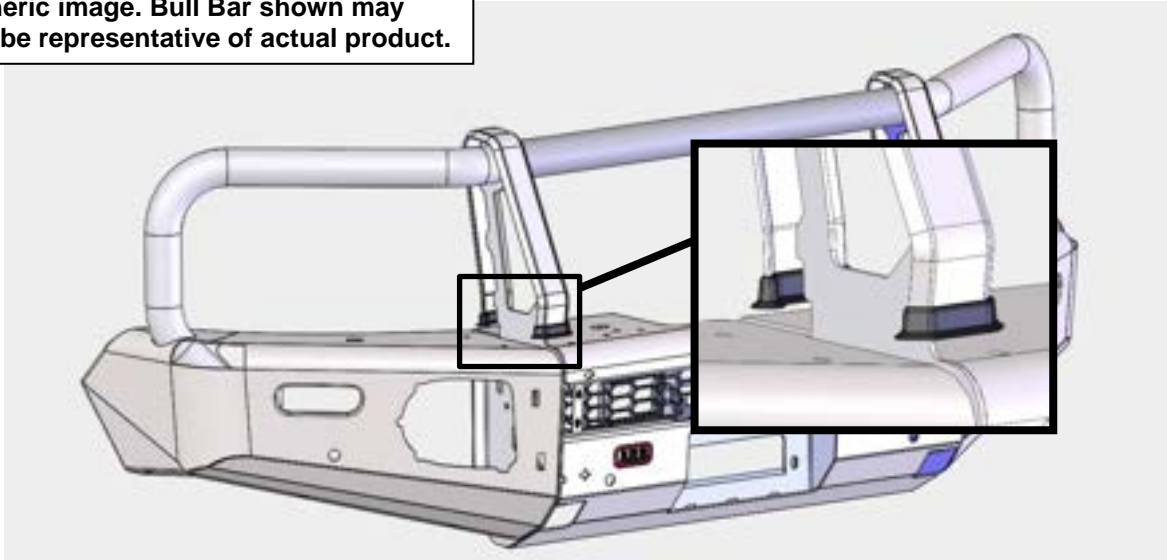

13. From the rear of the bar, slide the rear buffer sections under the rubber mouldings.
Fit 4 x screws and washers. Do not tighten screws. Leave enough play in buffers for adjustment later.

Note: Ensure that the skirts of the rubber intersection mouldings are not folded back on themselves and are sitting flat against the buffers.

Generic image. Bull Bar shown may not be representative of actual product.

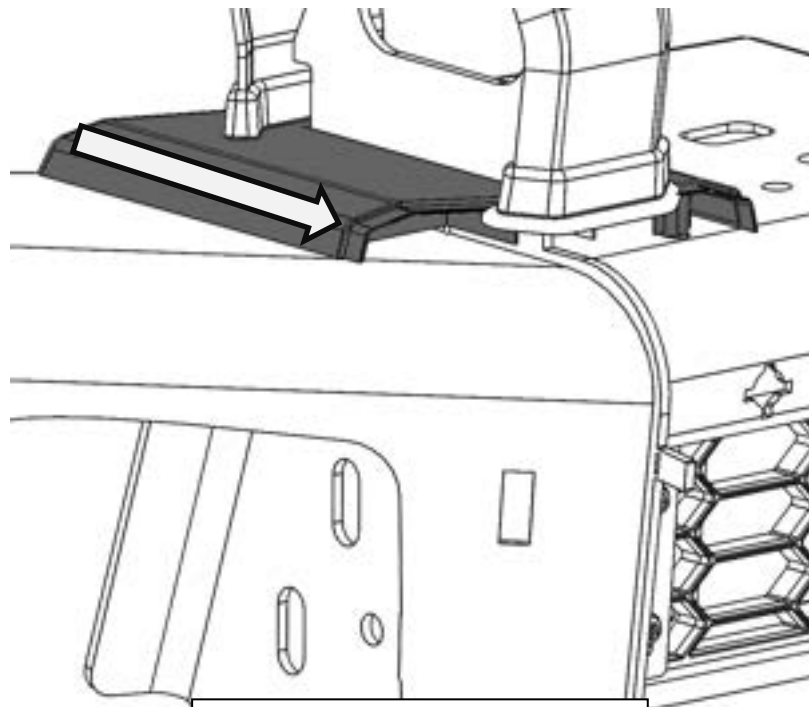

Fit washers under screw heads

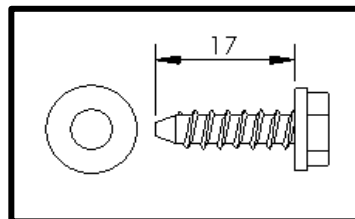

14. By aligning the front buffer with the tongue of the rear buffer, attach the front buffers to the front face of the bar. Ensure each buffer sits flat against the face of bar and is keyed into the top section of the rear buffer.

Secure wing side using retaining clips.

Secure inner side using the angled cup washers, flat washers and screws.

The widest point of the cup washers goes to the top of the bar.

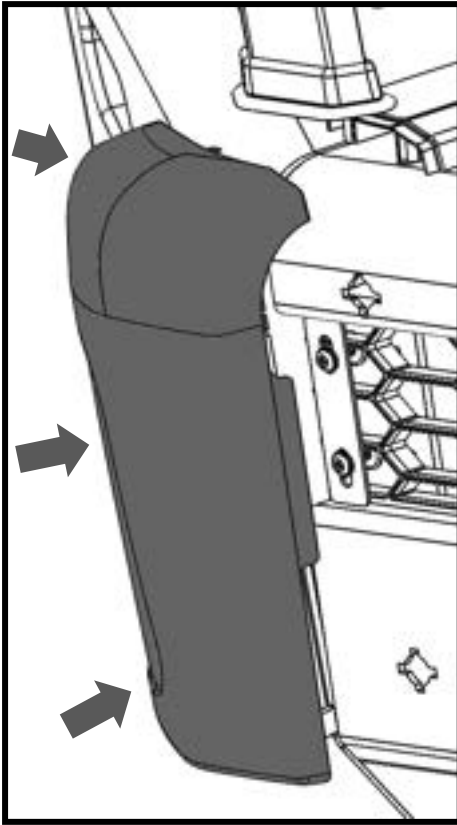

Generic image.
Bull Bar shown
may not be
representative of
actual product.

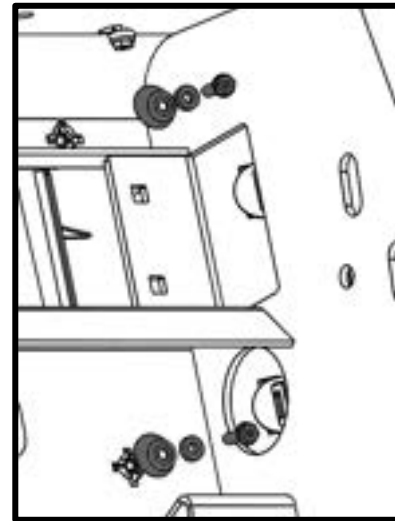

Fit washers under screw heads.

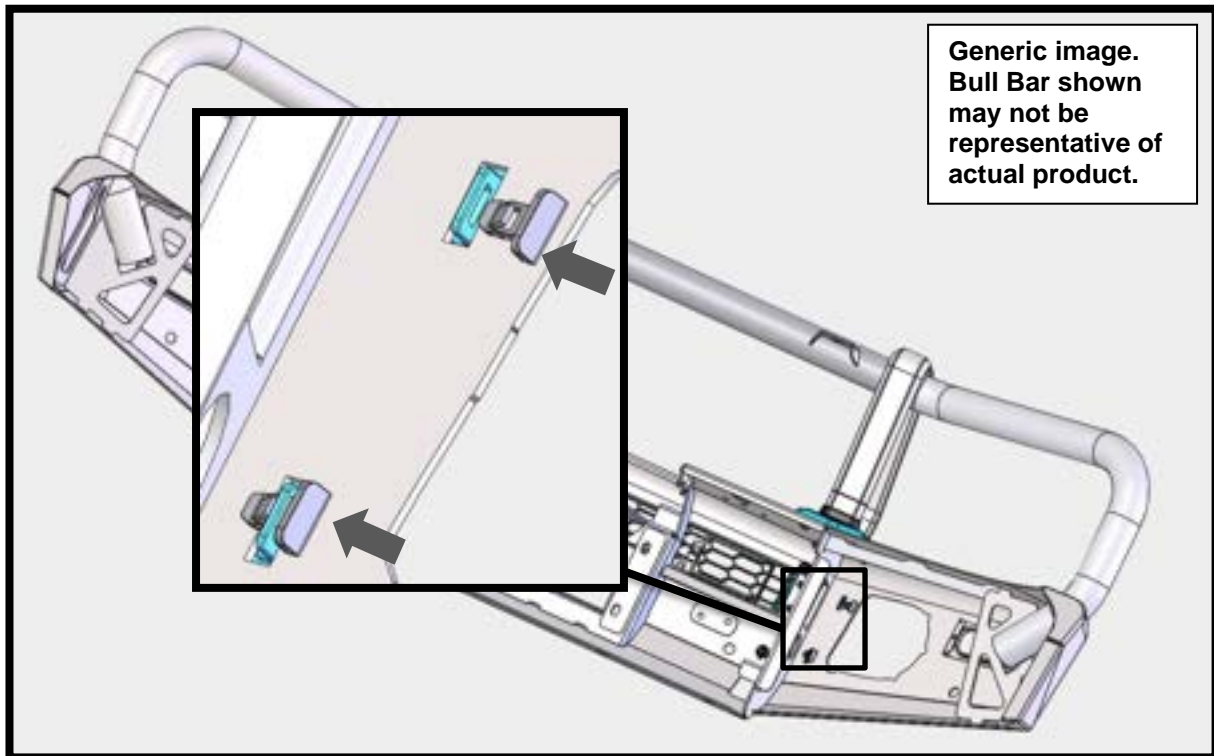
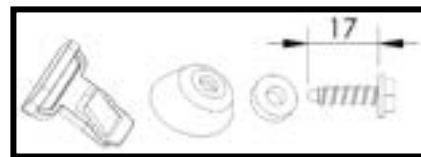

Generic image.
Bull Bar shown
may not be
representative of
actual product.

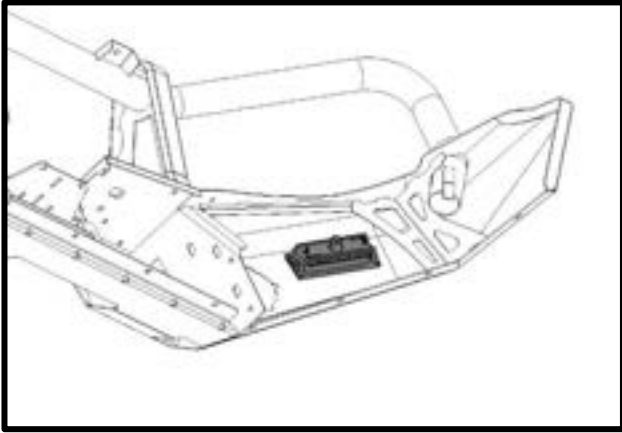

1. Fit the small plastic (square) grommets to the bar and attach the combination LED lamps to the bar using the screws provided with the lamp kit.

Note: There are subtle arrows on the LED indicators that should face outward

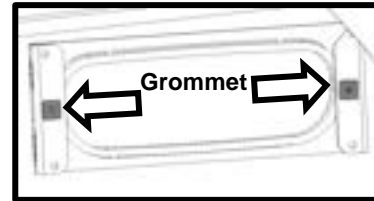

2. Using supplied scotch locks for the electrical connections, connect the LED indicator/clearance light looms as per table below and table in supplied light instructions.

Note: The cable color column is referencing the wires that are leading into the front headlight housing that control the OE blinker and running lights.

LED INDICATOR/CLEARANCE LOOM	
CABLE COLOR	FUNCTION
GREEN/PURPLE	RHS INDICATOR (+)
BLUE/WHITE	LHS INDICATOR (+)
GREY/BROWN	RHS CLEARANCE (+)
GREY/PURPLE	LHS CLEARANCE (+)
BLACK	GROUND (-)

FITTING BAR TO THE VEHICLE

1. Ensure all other aftermarket accessories such as driving lights/winch/UHF aerial have been fitted to the bull bar.



2. Measure the distance between the outside faces of the (2) mounts. Measure the distance between the inside, mating, faces of the bar.
3. Using the supplied mount spacers, install an even number of spacers on each side without going over the required width dimension to install the bar. These spacers are installed using (2) M6 x 35 hex bolts and flange nuts.

Note: These spacers can be used to position the bar left to right.



4. With the aid of a lift table or one or more assistants carefully and safely lift, then position and loosely bolt the bull bar to the mounts using (2) M12 x 50 hex bolts, large flat washers, and M12 flange hex nuts.

Note: Do not tighten these fasteners yet.



5. With certain winches it may be necessary to trim the lower portion of the center grill section for clearance.

**15 - 20 mm (5/8" - 3/4") GAP
REQUIRED AT QUARTER PANELS**

6. Ensure the bull bar is sitting on the vehicle level and the gap between the bumper cut and the bull bar wing is even.

**10 - 15 mm (3/8" - 5/8") GAP
REQUIRED AT BUMPER FASCIA**

7. If the bull bar is not centred on the vehicle, move the spacers installed in step 3 of this section around accordingly to move the bar.



8. Once happy with the position of the bull bar and the clearances, ***tighten all the mount bolts to the specified torque.***

 **M12 - 77 Nm.**

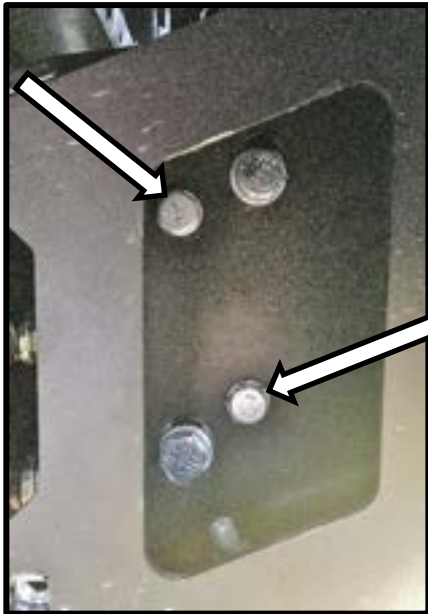

- Using the M10 pilot holes in the bull bar uprights, drill the two pinning holes through mounting brackets on each side. Fit the M10 x 35 hex bolt, flat washer, and flange hex nut sets through these holes and torque to the specified value.



M10 - 44 Nm.

Hint: Right angle drill head will help.



Warning: Cutting operations can result in flying debris, safety glasses should be worn.



- Assemble and install combination light surrounds (p/n 3163082) as per instructions no. 3789190 supplied with surround kit. Note: Optional fog lamps can be installed at this point as per fitting instruction supplied with fog lamp kit no. 3500910
- If installing fog lights Install ARB wiring loom 3500520 and switch into vehicle. Refer to instructions supplied with loom.

Hint: Loosely fit top bracket to Foglight Surround, then pivot into place through the bar aperture.

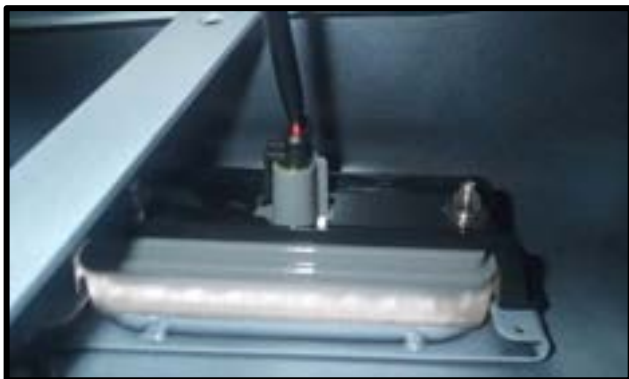

- Connect indicator looms to combination LED Indicator/Clearance light.

Caution: Cable tie all cables together and keep all cables clear of sharp edges and all moving parts. Check the operation of all lights wired during bar fitment.



4. Prepare fender liners for cutting by marking as shown
5. Measure and mark 170mm from the outer edge



6. Measure and mark 100mm from the bottom of the center hole as shown..



7. Connect the dots as show. Follow the line to each of the out edges.



8. Cut along the line, discard excess.





9. Insert (4) M10 cage nuts into the mating holes on the bar for the center stone shield as shown in the diagram.
10. Install the center stone shield onto the bar using the (4) M10 x 35 hex bolts and flat washers into the cage nuts.
11. Attach the center stone shield to the front crossmember of the vehicle using the (2) hex flange bolts taken off earlier.



12. Insert the (10) M6 cage nuts into the square cut-outs along the edge of the wing panels.
13. Insert the remaining (2) M10 cage nuts into the mating holes for the wing panels on the bar.
14. Install the wing panels using M6x35 button head screws and flat washers sets. Make sure the fender well liner is tucked into the wing panel while installing.



 M6 - 9 Nm.

 M10 - 44 Nm.

FINAL CHECKS:

- Check wiring connections to fitted lights.
- Check operation of all lights.
- Check operation of winch if fitted.

IMPORTANT: Check that all piping and wiring is clear of sharp edges and pinch points. Adjust any piping to clear the bull bar or mounts by a minimum of 15mm.

FINAL PRODUCT ON VEHICLE

