



FITTING INSTRUCTIONS

Part Number: 3915060. F/KITS: 6173657 & 6173664. (P/C MILL. GREY)
3915080. F/KITS: 6177990 & 6173664. (P/C BLACK)

Product Description: S/BUMPER TUNDRA – 99-06 SRS NFO 12-15

Suited to vehicle/s: TOYOTA TUNDRA 03-06 W/SRS

Optional Fitting Kit: 3500590 – ARB FFR FOG LIGHT KIT.
3500640 - ARB AUX FOG LIGHT ADAPTOR
3500530 – ARB AUX FOG LIGHT LOOM - NON FACTORY FOG LAMP VEHICLES.
3500680 – FOG LAMP HOUSING CLEAR LENSE KIT.

WARNING

REGARDING VEHICLES EQUIPPED WITH SRS AIRBAG:

When installed in accordance with these instructions, the front protection bar does not affect operation of the SRS airbag.

ALSO, NOTE THE FOLLOWING:

- ◆ This product must be installed exactly as per these instructions using only the hardware supplied.
- ◆ In the event of damage to any bull bar component, contact your nearest authorised ARB stockist. Repairs or modifications to the impact absorption system must not be attempted.
- ◆ Do not use this product for any vehicle make or model, other than those specified by ARB.
- ◆ Do not remove labels from this bull bar.
- ◆ This product or its fixing must not be modified in any way.
- ◆ The installation of this product may require the use of specialized tools and/or techniques
- ◆ It is recommended that this product is only installed by trained personnel
- ◆ These instructions are correct as at the publication date. ARB Corporation Ltd. cannot be held responsible for the impact of any changes subsequently made by the vehicle manufacturer
- ◆ During installation, it is the duty of the installer to check correct operation/clearances of all components
- ◆ Work safely at all times
- ◆ Unless otherwise instructed, tighten fasteners to specified torque

ARB 4x4 ACCESSORIES

Corporate Head Office

42-44 Garden St
Kilsyth, Victoria
AUSTRALIA 3137

Tel: +61 (3) 9761 6622
Fax: +61 (3) 9761 6807

Australian enquiries
North & South American enquiries
Other international enquiries

sales@arb.com.au
sales@arbusa.com
exports@arb.com.au

GENERAL CARE AND MAINTENANCE

By choosing an ARB Bar, you have bought a product that is one of the most sought after 4WD products in the world. Your bar is a properly engineered, reliable, quality accessory that represents excellent value. To keep your bar in original condition it is important to care and maintain it following these recommendations:

- Prior to exposure to the weather your bar should be treated to a Carnuba based polish on all exposed surfaces. It is recommended that this is performed on a six monthly basis or following exposure to salt, mud, sand or other contaminants.
- As part of any Pre Trip Preparation, or on an annual basis, it is recommended that a thorough visual inspection of the bar is carried out, making sure that all bolts and other components are torqued to the correct specification. Also check that all wiring sheaths, connectors, and fittings are free of damage. Replace any components as necessary. This service can be performed by your local authorized ARB Stockist.

FITTING REQUIREMENTS



IMPORTANT:

- This winch bumper is suitable only for Warn 10,000lb, 12,000lb winches only.

REQUIRED TOOLS FOR FITMENT OF PRODUCT:

METRIC SOCKET SET	METRIC RING AND OPEN ENDED SPANNER SET
ELECTRIC DRILL 13 MM CAPACITY	8mm or 5/16" DRILL BIT
BASIC TOOL KIT	PHILLIPS AND FLAT BLADE SCREW DRIVER SETS
TORQUE WRENCH (or WRENCHES Capable of covering from 3NM – 77NM)	BLACK SILICONE BASED RUBBER ADHESIVE OR SIKAFLEX
FELT TIP MARKER PEN	METRIC TAPE MEASURE or RULE
SCISSORS or SHARP KNIFE	

HAVE AVAILABLE THESE SAFETY ITEMS WHEN FITTING PRODUCT:

Protective eyewear 	Hearing protection 
--	--

NOTE: 'WARNING' notes in the fitting procedure relate to OHS situations, where to avoid a potentially hazardous situation it is suggested that protective safety gear be worn or a safe work procedure be employed. If these notes and warnings are not heeded, injury may result.

FASTENER TORQUE SETTINGS:

SIZE	Torque Nm	Torque lbft
M6	9Nm	7lbft
M8	22Nm	16lbft
M10	44Nm	32lbft
M12	77Nm	57lbft

PARTS LISTING

APPLICATION.	PART No.	QTY	DESCRIPTION
BUFFER FITMENT	6151128	12	NUT FLANGE M6
	3162153	1	BUFFER LHS
	3162154	1	BUFFER RHS
FOG LAMP HOUSINGS TO BULL BAR	3163082	1	FOG LAMP HOUSING KIT
INDICATORS TO BULL BAR	6821287	1	LED INDICATOR/CLEARANCE KIT PAIR
	6821116	4	NYLON PLUGS
	180302	6	CABLE TIES
SAHARA TUBE FITMENT	6151255	2	BOLT M12 X 40mm
	4581049	2	WASHER FLAT M12
	4581050	2	WASHER SPRING M12
	6131189	1	CHROME TUBE
MOUNT ASSY TO VEHICLE	3756254L	1	BRACKET IMPACT ABSORBER LHS
	3756254R	1	BRACKET IMPACT ABSORBER RHS
	4581010	4	WASHER FLAT 35 x 14 x 3mm
WINCH	4581041	4	WASHER FLAT 25 X 11.5 X 1.6
ROLLER FAIRLEAD FITMENT	4581049	4	WASHER FLAT M12
CONTROL BOX FITMENT	3756250	1	CONTROL BOX BRACKET
	BLR560	2	BATTERY LEAD RED
	BLB560	2	BATTERY LEAD BLACK
	6151017	3	BOLT M6 X 16MM
	6151128	3	NUT FLANGE M6
	3756260	1	BKT INSULATOR COVER
	3756248	1	BKT INSULATOR BASE
180302	6	CABLE TIES	
WINCH COVER FITMENT	6151128	2	NUT FLANGE M6
	6151256	2	SCREW M6 S/STEEL BUTTON HEAD
	6191001	1	WINCH COVER EXTRUSION
	6522009	1	WINCH COVER (MILL. GREY)
	6523607	1	WINCH COVER PANEL (BLACK)
	4581304	2	WASHER M6 S/S
NUMBER PLATE FITMENT	6151017	2	BOLT M6 x 16mm
	6151128	2	NUT FLANGE M6
	6781408	1	TAPE DOUBLE SIDED
RUBBER EXTRUSION FITMENT	6821116	16	SQUARE PLASTIC PLUG
	6151176	16	SCREW SELF TAPPING 12mm 8G
	6191002	2	EXTRUSION
	3193686	2	MOUNT STRIPS
BAR TO MOUNT ASSEMBLY	6151255	6	BOLT M12 X 40mm
	4581050	6	WASHER SPRING M12
	4581007	6	WASHER FLAT M12 LARGE
	6151020	2	BOLT M8 X 16mm
	6151132	2	NUT FLANGE M8
CB AERIAL PLUGS	3162152	2	PLASTIC PLUG DIA16
SPLASH PAN FITMENT	3314419	1	PAN
	6151020	3	BOLT M8 X 16mm
	6151132	3	NUT M8 FLANGE

FITTING PROCEDURE – PREPARATION TO VEHICLE

1. Remove the bumper bar from the vehicle.



2. Using sharp scissors or a cutting blade, cut the plastic inner guard as per line shown in the photo. (RH shown).

3. Connect the LED indicator/clearance harnesses to the vehicle using the wiring looms (6821286) and scotch locks provided in the LED indicator/clearance kit (6821287).

Connect vehicle RH indicator wire to Green wire on LED loom.

Connect vehicle RH parker wire to Red wire on LED loom

Connect vehicle ground wire to Black wire on LED loom.

Repeat for LH of vehicle.

4. Allow the LED Looms (6821286) to hang freely for connecting to the bull bar LED's at Step 41.

5. **Optional Fog Lamp fitment:**

For vehicles with Factory Fog lamps:

Connect RH & LH Fog Lamp wiring using 3500640-ARB Aux fog light adaptor and connect to Factory Fog Lamp loom.

For vehicles without Factory Fog lamps:

Connect RH & LH Fog Lamp wiring using Fog Lamp Wiring Loom kit – 3500530.

6. Allow the Fog Light looms to hang freely for connection to the bull bar Fog Lights at Step 42.

PREPARATION TO VEHICLE (Continued)

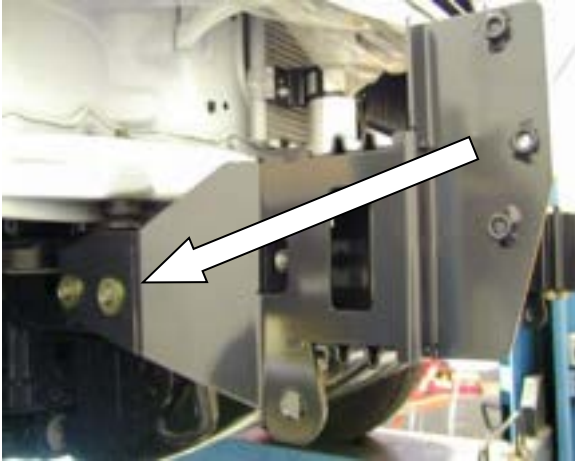

7. Mount the Impact Absorber brackets to each side of the chassis using original fasteners.
Fit flat washer 35 x 12 x 2.5mm to side hole of bracket and fasten.

PREPARATION TO BULL BAR



8. Insert the side buffers through the holes and fix using the M6 flange nuts. (Do not over tighten). (RH shown).

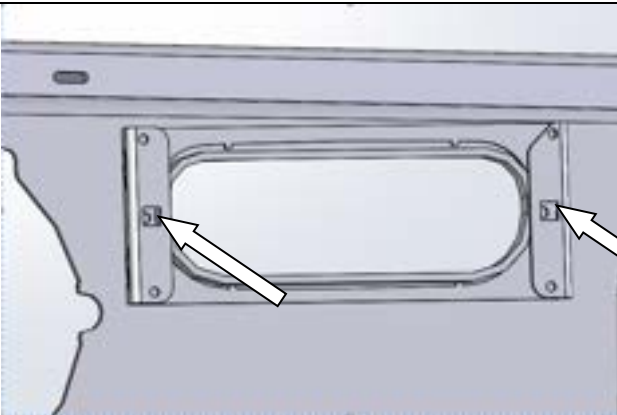

9. Install Nylon plugs (6821116). (4 off) Into Clearance Light/Turn Signal Brackets. (RH Shown).

PREPARATION TO BULL BAR (Continued)



10. Fit fog lamp housings (3163082) into the bull-bar fog lamp cutouts as shown. (RH Shown).

If fitting fog lamps refer to fitting instructions (3789190) in the fog lamp housing kit (3163082) for details before mounting the housings in the bull-bar.

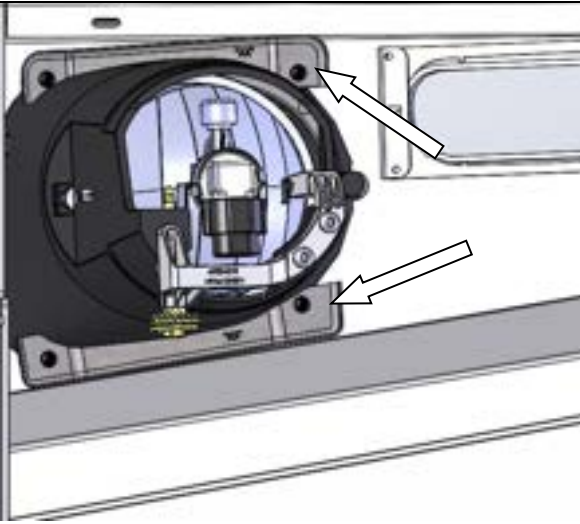

11. Secure into position as indicated using the 2 x fog lamp clamps and 4 x self-tapping screws.

(RH Clamps Part No. 3759115R).
(LH Clamps Part No. 3759115L).

Note: Shown with generic Fog Lamp fitted in this view.

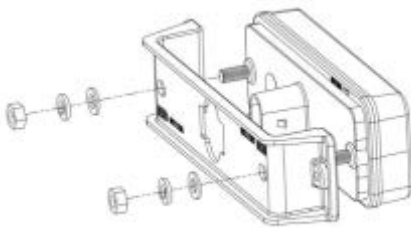

12. Install 6821285 bracket onto LED lamp with 2 x flat washer, 2 x spring washers and 2 x M6 nuts as shown.

Torque to specification.



M6 - 3 Nm.

NOTE: Do not over-tighten.

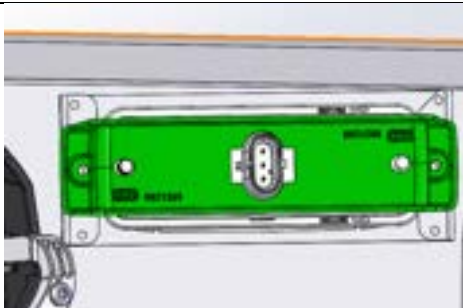

13. Install LED lamp with bracket into bull-bar using 2 x 15mm mounting screws provided. (RH Shown).

Note: Do not fully tighten.

IMPORTANT: The clearance LEDs must be on the outboard edge of the bull-bar. To achieve this, position lamp with arrows facing outside of vehicle as shown below.

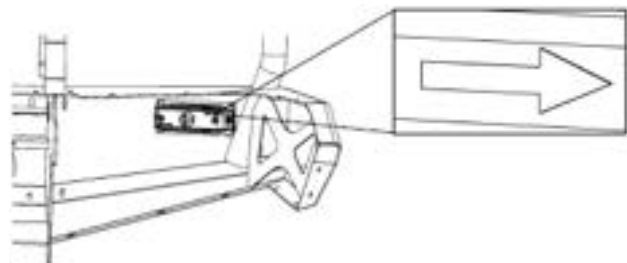
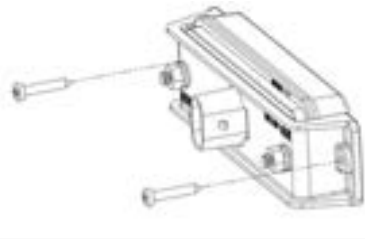

PREPARATION TO BULL BAR (Continued)



ADJUST GAPS TO BE THE SAME

14. Viewing the installed LED Lamps from the front of the bull bar – adjust the Lamp positions so that they are central in the formed apertures and any gap on either side is the same.

- Once adjusted fully tighten the 15mm mounting screws.



15. Push the top Sahara tube through the hole in the buffer and fasten using the M12 x 40mm bolts, washers and spring washers.

Torque to specification.



M12 - 44 Nm.

NON-WINCH FITMENT ONLY



IF FITTING A WINCH MOVE ON TO STEP 20.

16. Wrap rubber extrusion around the winch cover and trim excess.
17. Place spacer washers over the winch cover fixing holes, located on the top face of the winch bumper.
18. Place the winch cover on top of the winch bumper in line with the mount holes.

Bolt together using the M6 button head stainless steel screws and M6 nuts.

Torque to specification.



M6 - 9 Nm.



19. Bolt the number plate through the top holes using M6 X 16mm bolts and M6 flange nuts. If desired double sided tape can be used down the sides of the number plate.

WINCH FITMENT ONLY

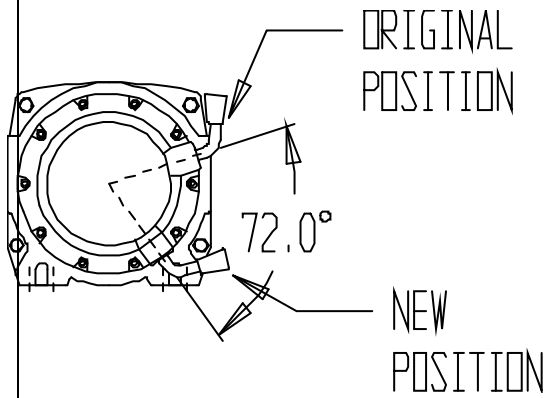

20. To place the winch clutch handle in a convenient location the winch gearbox must be rotated 2 hole spacing's, 72 degrees, in a clockwise direction when viewed from the gearbox end. Place the winch on its end and remove all gearbox bolts. Gently raise the gearbox just enough to rotate it. Do not completely remove the gearbox and avoid damaging the gasket. Refit all bolts and tighten.

NOTE: To avoid un-meshing the gears take care not to lift the assembly more than a couple of millimetres while rotating to the desired position.

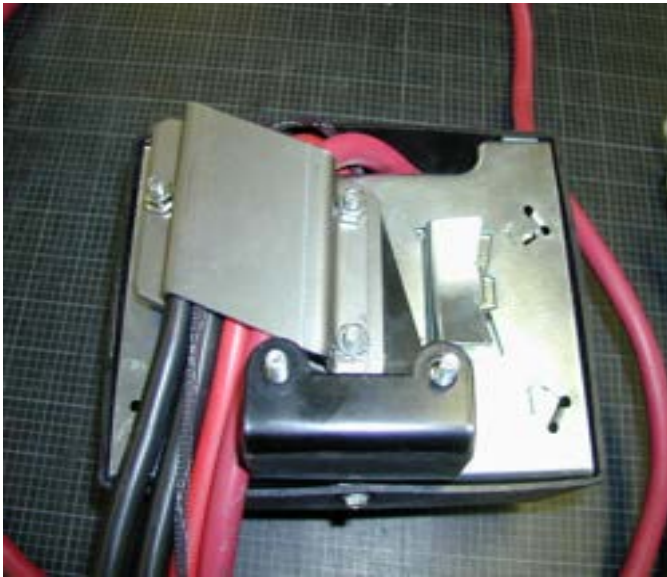

21. Undo the screws on the side of the control box, remove the top cover and replace the three short leads with the longer ones supplied in the fitting kit.
22. Position the control box bracket, then the lead insulator bracket to the back of the control box.
23. Ensuring the leads are neatly on top of the bracket place the cover bracket on and fasten with the control box nuts and the M6 x 16mm bolt and flange nut.



24. Fasten control box assembly to the bar using the M6 x 16mm bolts and flange nuts.

WINCH FITMENT ONLY (Continued)



25. Install the winch and roller fairlead using bolts, nuts and spring washers supplied by Warn, and the 25 x 11.5 x 1.6mm flat washers supplied in the bolt kit. Refer to Warn installation instructions for correct procedure. Adjust winch in slots until the winch is centralized in the bull bar.
26. Connect Control box leads to winch. Refer to the Warn winch handbook for additional information.



27. Peel off one side of the double sided tape and adhere to the top rear side of the number plate. Note: Clean the adhering surfaces before applying tape with an alcohol solvent.
28. Peel off the other side of the tape and bolt to the winch bumper with the M6 X 16mm bolts and M6 flange nuts through the lower holes of the number plate.
29. Press firmly to the top of the number plate so the tape can properly adhere.

PREPARATION TO BULL BAR (Continued)



30. The rubber extrusion contains a support section to assist in the moulding. Remove this section by tearing at one end. Discard this section.
31. Insert the square plastic plugs into the square holes on the top face of the wing.

PREPARATION TO BULL BAR (Continued)

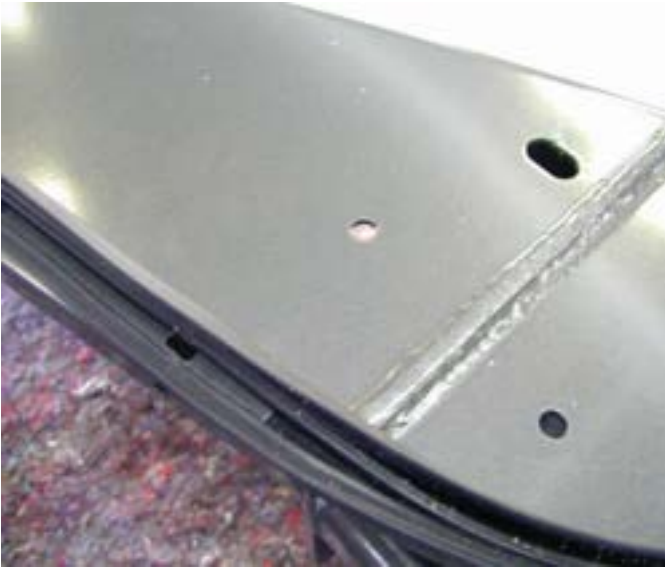

32. Insert the mount strips inside the channel section of the rubber extrusion. Make sure the flap section is on the outer side. Allow generous even amounts of excess at either end of the strip so that it can be trimmed later.



33. Using a Phillips head screw driver or cordless drill with a Phillips head tip fix the extrusions to the top of the wings using the self-tapping screws.



34. Using a sharp knife cut the excess rubber in line with the inside end of the wing. Only cut the inside excess, the other end will be cut when the winch bumper is fitted.

BULL BAR FITMENT TO VEHICLE



35. With the aid of another person carefully place the bar on the mounting brackets.
36. Horizontally and vertically align the bar to the body and fasten using the six M12 x 40mm bolts, large washers and M12 spring washers. Tighten all bolts so as the large washer deforms inside the cut-out.
37. Drill out the lower pin bolt hole on each side with a 8mm or 5/16" drill bit.
38. Fasten with 8mm x 16mm bolts and flange nuts.

Torque to specification.



M8 - 22 Nm.



M12 - 77 Nm.

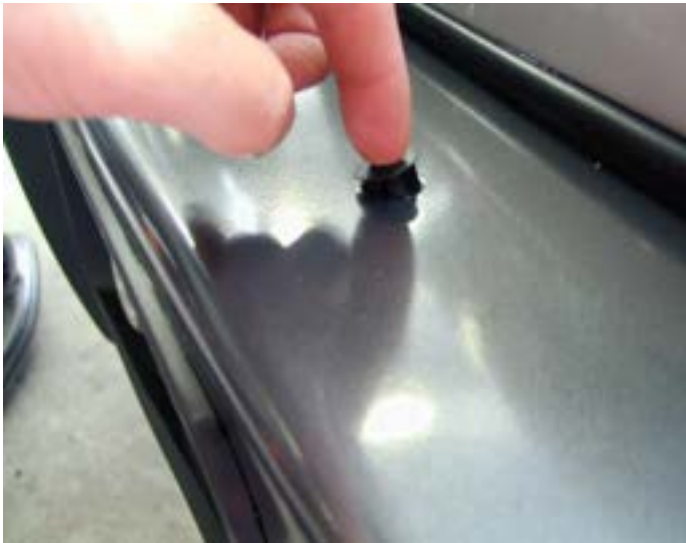

39. There are two 16mm dia. holes located on the top face of the bar. If no CB aerials are to be fitted the holes can be covered with the plastic plugs provided in the fitting kit.



(If fitting with a winch).

40. Feed the winch cable through the roller fair lead. Mount the hook to the end of the cable.

BULL BAR FITMENT TO VEHICLE (Continued)

Connect Loom to
LED lamp

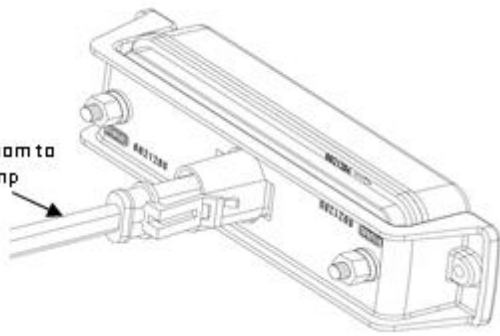

41. Connect the indicators/clearance lamps to the looms fitted during Steps 3-4.
42. If fitting fog lamps connect the fog lamp harnesses fitted at Steps 5-6, to the fog lamps.
 - **Cable-tie all wiring and wiring looms into safe and convenient locations.** Ensure that all cables are installed well clear of all sharp or moving parts using cable-ties from the bolt kit.
 - **Check that all lights work correctly.**
 - **Check and test winch if installed.**

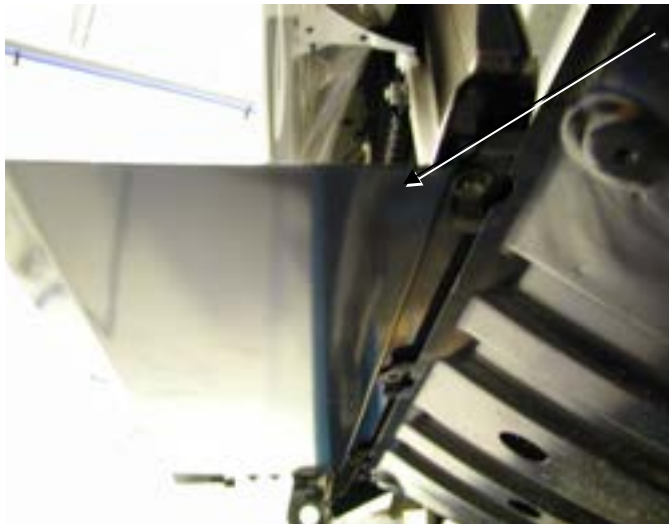

43. Undo the three front pan bolts and loosen the two rear ones.
44. Position splash pan between the body and the original pan and loosely fasten with original bolts.
45. Connect splash pan to underside of bar using the M8 x 16mm bolts and flange nuts.
46. Tighten all bolts.

Torque to specification.



M8 - 22 Nm.

24. (If fitting with a winch).

Connect the long winch + & - cables to the vehicle after the bar is installed.

Refer to the Warn winch manual for vehicle wiring instructions.

Ensure that these cables are installed well clear of sharp, hot or moving objects. Secure the winch cables to the vehicle and winch bumper with the supplied cable ties.

ONCE BAR IS FITTED:

- ◆ Ensure all bolts are tensioned correctly
- ◆ All wiring is clear of sharp edges or moving surfaces and secured properly
- ◆ Piping is secured well away from sharp or moving components
- ◆ Check operation of winch if fitted
- ◆ Check all wiring and connections to turn signal lamps, sensors, headlamp washers etc. are functioning correctly.