

DUAL CAB CENTRAL LOCKING CANOPY

Ascent Canopy USA ONLY AC24CXX – Ford Ranger Dual Cab 2024
(2024 Vehicle Production Onwards. Fits XL,XLT, Lariat, Raptor)



FITTING KIT: TAILGATE AND HEAD BOARD KIT 6178556. TUB MOUNT KIT 6178688

! PLEASE PROVIDE A COPY OF THESE INSTRUCTIONS TO THE CUSTOMER !

IMPORTANT:

- Vehicle bodies and vehicle specific installation can vary. Please read the following instructions as they refer to important information which could affect the quality of the final installation.
- It is advisable to have the canopy fitted by an authorised dealer.
- The majority of installation can be completed by one person (**however 4 people will be required to lift the canopy onto the vehicle**).

FITMENT:

- For Bed Liners and accessory Cargo Management Systems (with sliding tie down rail cleats), additional time for fitting is required including partial trimming of bed liners.
- All side tub rail plastic mouldings, Cabin Guards and Sports bars **must** be removed prior to canopy fitment. These components can be returned to the customer if required. The plastic cap on top of the tailgate is to remain assembled to the vehicle.
- **Specific to Ford Wildtrak models, fitting instruction 37801115 must be undertaken first to prepare the vehicle for canopy fitment.**
- **For PHEV vehicle fitments consult the workshop manager in relation to working safely with electric vehicles before beginning fitment.**
- **For improved water sealing at the tailgate, fit separate ARB tailgate sealing 6178014 for the sides of the tub and 6178102 for the floor of the tub.**

CARE OF YOUR CANOPY:

Please refer to the “owner’s manual supplement” to be given to the purchaser on installation, as per the details referred to in the second last page of these fitting instructions.

FOR HIGH VOLTAGE (HV) ELECTRIC VEHICLES





Work on and fitting parts to High Voltage (HV) electric vehicle which have the potential to involve an interaction with the HV systems on that vehicle presents significant risks of serious injury or death due to electric shock, arc flashes and potential explosions or fires.

When undertaking work or fitting parts that will likely involve an interaction with the vehicles HV system, appropriately qualified personnel must undertake such work or fitment of those parts in accordance with company procedures and local regulatory requirements. The qualifications required may vary depending on the location or region.

Failure to comply with these requirements and instructions may result in serious injury or death.

HAVE AVAILABLE THESE SAFETY ITEMS WHEN FITTING PRODUCT:

<ul style="list-style-type: none">• Protective eyewear		<ul style="list-style-type: none">• Hearing protection	
--	---	--	---

NOTE: 'WARNING' notes in the fitting procedure relate to OH&S situations. To avoid a potentially hazardous situation it is suggested that protective safety gear be worn or a safe work procedure be employed. If these notes and warnings are not heeded, injury may result.

TOOL LIST FOR FITMENT:

<ul style="list-style-type: none">• Torque Wrench 0-25Nm• Sockets 7, 8, 10 & 13mm sockets• Socket extension bar and driver• Spanners, ratchet type, 10 and 13mm.• Tape measure• T20, T27, T30, T40, Torx Drive alun keys and bits for socket drives.• Electric or pneumatic drill• Pneumatic rivet gun.• Drill bits: 5.2, 6, 16, 21mm• Drill stop for 6mm drill bit• Step drill to 21mm diameter• 25mm hole saw• Caramel wheel	<ul style="list-style-type: none">• Engineer's scribe• Silicon Caulking Gun• <u>Neutral cure</u> Clear Non-Acetic Silicon• Spray trigger bottle with soapy water• Phillips head screwdrivers• Flat blade screwdrivers• Side Cutters• Cleaning cloths / rags• Knife• Sharp Scissors• Prepsol/ Silicon remover.• Deburring tool• Rubber printing roller.
--	--

FITTING THE CANOPY IS UNDERTAKEN THE FOLLOWING STAGES:

1. Removing any sports bars, cabin guards, side bed rail plastic caps and roll top tonneau covers. (For Wildtrak vehicles - please read and undertake fitting instruction part no 37801115 first).
2. Fitting the tailgate door sealing stop assembly.
3. Fitting the tub sealing blocks.
4. Fitting the tub mounting brackets.
5. Fitting canopy wiring.
6. Fitting the canopy to the vehicle
7. Operational checks and adjustment options for doors and windows.
8. Recording of key code and owner's manual supplement.
9. Check list and sign off.

NOTE: DURING THE INSTALLATION IT IS NECESSARY TO DRILL SOME HOLES THROUGH THE VEHICLE'S TUB SHEET METAL. IT IS RECOMMENDED THAT THESE ARE DE-BURRED AND THE RUST INHIBITOR PROVIDED BE USED TO AVOID CORROSION. ANY SWARF LEFT OVER SHOULD BE CLEANED FROM TUB

!! IMPORTANT !! other than specifically specified in this instruction

REQUIRED SCREW TORQUES: M6=9Nm M8=20Nm

















SCREW TORQUES: These must be adhered to avoid warranty issues and should be checked at vehicle service intervals.





















THE FITTING KIT CONTAINS:











Packed under the canopy are 2 fitting kits:

6178556 contains the tailgate door stop sealing kit and tub front head board mounting rail.

6178688 contains the main hardware for mounting the canopy.

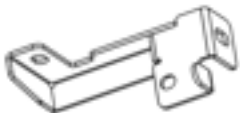
Kit No	Part No	Picture	Qty	Description
1). 6178556 TAILGATE AND HEAD BOARD KIT	668AQ041		1	ASSEMBLY TAILGATE DOOR SEALING STOP
	668PD156		1	FRONT MOUNT RAIL FOR FRONT OF TUB
	668PB018		1	ROLL OF FOAM TAPE 26 x 2 x 1650mm
	6151626		6	PAN HEAD HI LO SCREW
	4584295		6	WASHER FLAT M6 x 12
2). 6178688 MAIN CANOPY HARDWARE KIT	6602018		6	ALCOHOL WIPES
	665505		1	RUST INHIBITOR SACHET
	668PB033		1 PAIR	TUB FRONT CORNER SEALS - PAIR OF
	668PE051R		2	RH SPACER LOCATOR TUB RAIL
	668PE051L		2	LH SPACER LOCATOR TUB RAIL
	668PD151		6	10MM THICK SPACERS-TUB RAIL
	668PE057R		1	RH REAR TUB RAIL SEAL
	668PE057L		1	LH REAR TUB RAIL SEAL
	668PM005		1 PAIR	FRONT TUB CORNER SEAL BRIDGE
	665037		2	ROLL- CLEAR TAILGATE PROTECTION TAPE 30mm WIDE
	665076		2	BUMP ON STRIP OF 5 PIECES



668PB006		4 PAIR	PAIR OF DIE CUT BLACK STICKERS
6152128		6	FIR TREE CLIP FOR 6MM HOLE
4584435		6	RUBBER FLAT WASHER OD19X6.5IDX0.8MM- BLACK
6609087		2	RIVET 3/16 BLK
6151881		6	M8 x 35 TORX PAN HEAD SCREW – BLACK (T40)
6151625		12	M8 x 1 x 25 TORX PAN HEAD SCREW – BLACK (T40)
6151681		2	SCREW HXHD M8 x 35 BLACK
6152008		3	HEX FLANGE HEAD BOLT M6 x 25 - BLACK
6253421		2	SPACER 20 OD x 13.5mm THICK
4581082		4	M6 x 20OD x 1.2mm FLAT WASHER BLACK
4581085		12	M8 x 19 OD x 1.2mm FLAT WASHER BLACK
4581303		12 (14)	M8 x 25.4 OD x 3 WASHER -- BLACK (If 668PD170 not present)
668PD170		2 (0)	M8 x 28 FLAT SIDED WASHER (If 12 4581303 present)
6151212		6	M8 x 1.25 BLACK NYLOC NUT
6151223		4	M6 x 1 BLACK NYLOC NUT
6151173		1	M6 x 1 WIZZLOCK FLANGE NUT – BLACK
668PB032		1 PAIR	PAIR OF FOAM TAPE DIE CUTS – REAR TUB BRACKET CORNER SEALS- SELF ADHESIVE
665044		1	PRIMER PENCIL STICK
668PJ033		1	ELECTRICAL LOOM - VEHICLE HARNESS- USA SPEC RANGER ONLY
668PB015		2	FOAM ANTI RATTLE 30mmx150mm STRIPS

668PJ015		1	ELECTRICAL RELAY BOX
6821293		1	CABLE TIE BASE
180302		23	CABLE TIES – 200mm
3199779		1	GRINDING PLATE (DISPOSABLE)
668AQ026		2	NUT PLATE MID MOUNT BRACKET
668PD167R		1	RH FRONT TUB CORNER BRACKET
668PD167L		1	LH FRONT TUB CORNER BRACKET
668PD157R		1	RH REAR TUB CORNER MOUNTING BRACKET
668PD157L		1	LH REAR TUB CORNER MOUNTING BRACKET
668PD159R		1	RH REAR TUB CORNER SEALING BRACKET
668PD159L		1	LH REAR TUB CORNER SEALING BRACKET

SECTION 1: REMOVAL OF SPORTS BARS, BED RAIL PLASTIC CAPS, CABIN GUARDS AND ROLL TOP TONNEAU COVERS

- 1.1) Remove any sports bars fitted. Remove plastic side mounted tub rail bed caps on the vehicle tub for XLT or XL (**!! Important !!- squeeze the plastic clips under the lip of the tub with long nose pliers before unclipping them to avoid distorting the sheet metal**). If fitting a canopy to a Wildtrak level vehicle with roll top tonneau cover, first undertake fitting instruction part number: **37801115** For Wildtrak 2022 Tub Preparation for Canopy.
- 1.2) The sports bar or roll top tonneau cover will need to be removed if fitted and returned to the customer if requested to do so.
- 1.3) Cargo Management System (CMS) side rail track accessory hardware does not need to be removed, refer to steps in this fitting instruction as partial hardware removal is required.
- 1.4) Bed liners do not require removal based on OEM supplied products.

SECTION 2: FITTING THE TAILGATE DOOR SEALING STOP ASSEMBLY

	<p>2.0) Place tailgate in down position.</p>
<div style="display: flex; flex-direction: column;"> <div style="display: flex; align-items: center;">  <div style="border: 1px solid black; padding: 5px; margin-left: 10px;"> <p>SPRAY 668PE057R WITH SOAPY WATER</p> </div> </div> <div style="display: flex; align-items: center; margin-top: 10px;">  <div style="border: 1px solid black; padding: 5px; margin-left: 10px;"> <p>SPRAY CAVITY WITH SOAPY WATER</p> </div> </div> <div style="border: 1px solid black; padding: 5px; margin-top: 10px; width: fit-content;"> <p>ANGLE REAR RUBBER BLOCK INTO CAVITY</p> </div> </div>	<p>2.1) Take rear tub rail sealing block (668PE057R) and spray with soapy water.</p> <p>2.2) Spray the rear corner hole in the top tub rail at the back of the vehicle with soapy water.</p>

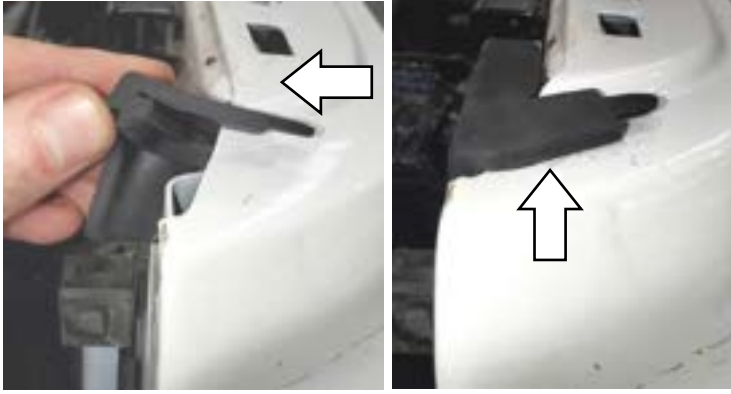

2.3) Angle back the corner of the rubber clipping lip feature of the sealing block into the hole in the tub and slide the recess over sheet metal edge.



CHECK CLIPPING LIP IS UNDER TUB SHEET METAL

2.4) Work the clipping lip of sealing block under the tub sheet metal top skin, by pushing the block back and forwards whilst pushing it inwards.

2.5) Check the clipping lip is fully engaged in cavity by lifting the block up and checking.

2.6) Make sure rubber block is sitting neatly in cavity. The bottom face of block should be sitting flat on the vehicle's tub rail.

Repeat for LH side using LH Sealing Block (665514L)

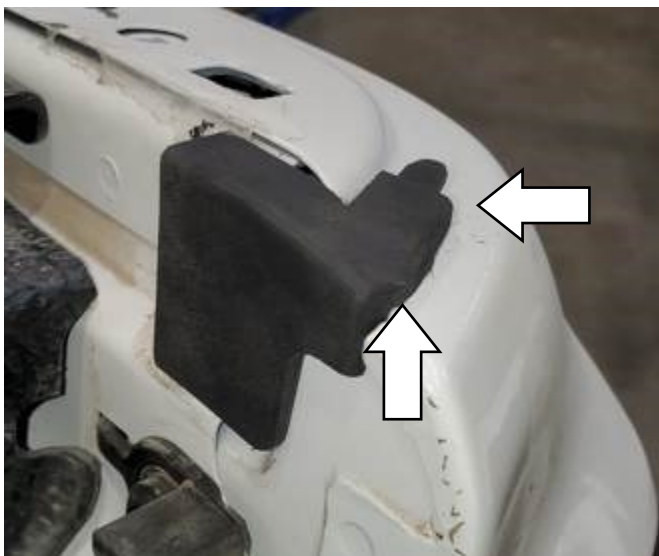

CHECK BLOCK IS SITTING FLAT AND NEAT IN PLACE ON THE REAR TAILGATE END OF THE SIDE TUB RAILS



REMOVE ALL
SCREWS AND
TAILGATE
LINER



2.7) If the tailgate plastic liner is present, remove all the T20 Torx drive screws and retain for refitment.

2.8) Remove the complete tailgate liner and retain it whilst leaving the rubber upper and lower extrusions in position.



2.9) Remove the metal inspection panel on the inside of the tailgate and retain it with it's screws for refitment later.

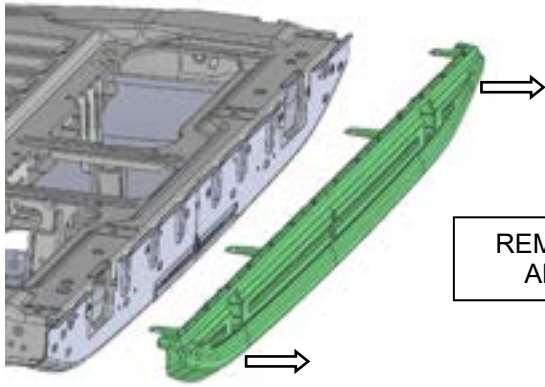

REMOVE OLD CAP
AND DISCARD

2.10) Remove the OE tailgate top cap and discard

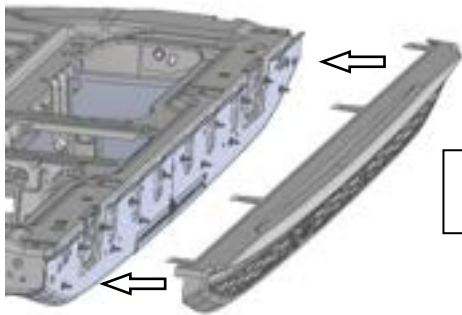

LOCATE NEW CAP IN
POSITION

2.11) Place new top cap (668AQ041) in position and from the inside, progressively screw down firmly in 6 places on the outermost locations (3 per side) using the Hi-Lo screws (6151626) and M6x12 washers (4584295).

Once fully fitted, refit both the inspection panel and tailgate liner.

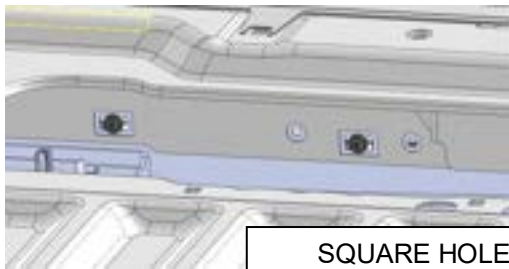

SQUARE HOLE DENOTES
SCREW LOCATION (6 places)

SECTION 3: FITTING THE TUB SEALING BLOCKS

Note: For clarity, the CMS side track rails has been removed from the tub.



3.1) Locate the open cavity under the upper front left-hand corner of the tub and clean with an alcohol wipe (6602018).



3.2) Take the left-hand foam block as per opposite from the pair of 668PB033.



3.3) With the grooved recess edge facing down, push the foam block up into cavity opening with recessed edge, with its short leg side to clip over the tub sheet metal edge on the front pillar cavity of the tub.



3.4) The foam sealing block is to be an interference fit with the underside of the side tub rail and fit firmly in place as shown. Position the top edge of the foam block to avoid covering weld nuts in the tub.



3.5) Use neutral cure non-acetic silicon to fill gaps and seal edges all around foam block and tub.

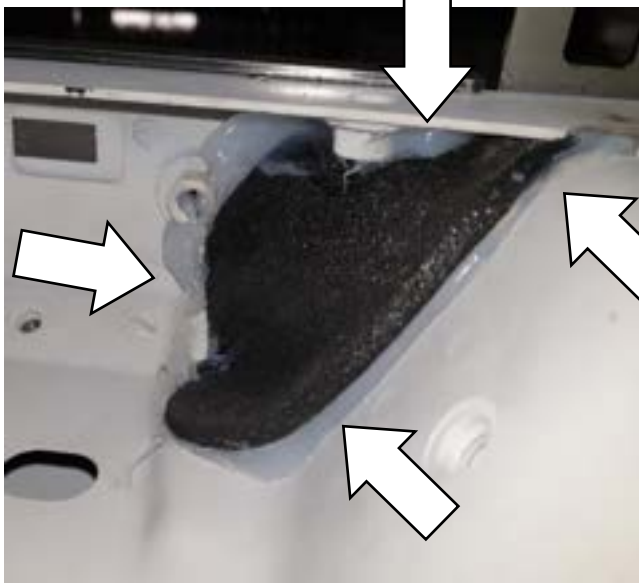

3.6) Silicon seal all around foam block as per picture.

Repeat steps 3.1 to 3.6 for sealing the tub using the right-hand tub corner sealing foam block.



- 3.7) On the right-hand side locate the electrical connector (**if fitted on Wildtrak models only for roll top tonneau covers**). Remove the clipping strap from the tub. Wrap the end of connector with electrical tape to seal it off on the open connection side and push the connector back through the open cavity hole and into the void of the front corner pillar.

SECTION 4: FITTING THE CANOPY'S TUB MOUNTING BRACKET SYSTEM



4.0) Use alcohol wipes (6602018) to clean the side top rails of the tub and front tub rail.

PLACE BLACK STICKERS OVER RECTANGULAR FRONT SIDE RAIL CORNER INNER HOLE AND TWO HOLES ON THE FRONT VERTICAL FACE OF TUB PER SIDE

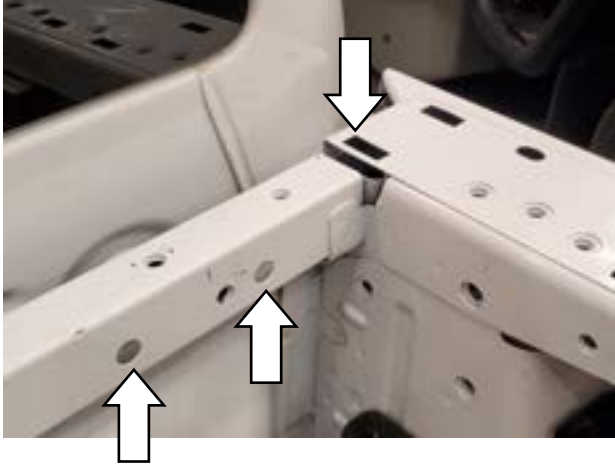

4.1) Ensure the sheet metal work in the front corners of the tub and along the 6 holes on the outer edges of the tub are not distorted by previously removing side bed rail cap covers. Straighten this if required to get a flat level surface.

Place 7 black sticker squares in total (668PB006) (which come as a pair of squares per backing sheet), over the holes in the front of the tub as shown.

ONE STICKER OVER CENTRE HOLE IN VERTICAL FACE OF FRONT TUB RAIL

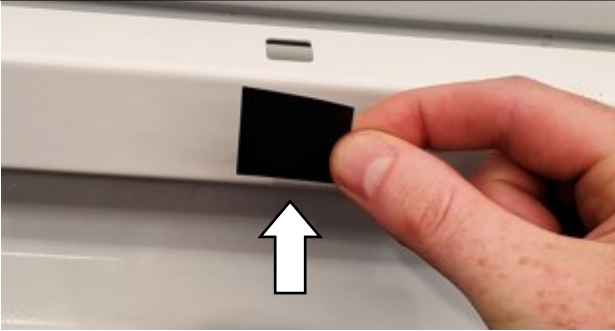

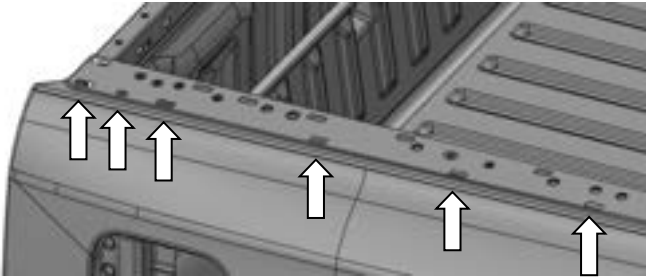

- 4.2) Use 1 roll of clear 30mm wide tape (665037) per side and cover the first 6 rectangular holes from the front along the outside edge of the side tub rails.
- 4.3) Cut the tape after 6th hole is covered and retain what is left on each roll for later use.
- 4.4) **Use firm pressure (or a roller) to apply the tape ensuring it seals to protect against water entry around each of the rectangular holes.**

Do both sides of the top tub rails.

6 HOLES UNDER THE FRONT TUB RAIL TO BE SEALED IF BEDLINER IS REMOVED



- 4.5) Under the front tub rail, the angled face has 6 holes **if a bedliner is removed**. The 6 holes in the tub need to be sealed. Over 6 fir tree clips (6152128) assemble rubber washers (4584435) under the head of the fir tree clips. Then install them into the vehicle's front tub rail.

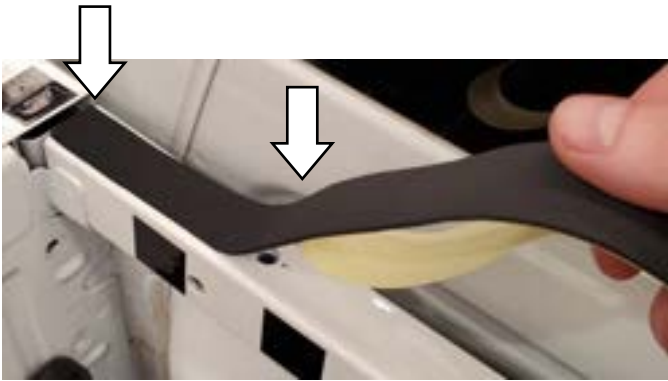

- 4.6) Assemble adhesive foam tape (668PB018) and mate the starting edge tightly against the side tub rail and run it along top face of the tub front rail, centrally. Ensure the holes in the upper surface of the front tub rail are covered and well-sealed by the foam tape. Cut the tape to length and mate the end up firmly to the side tub rail on the opposite side.



CUT ONE END TO LENGTH TO BUTT UP TO SIDE TUB

FILL GAP UNDER
FRONT TUB RAIL
AND FRONT
CORNER HOLES



FILL GAP FRONT
CORNERS OF TUB

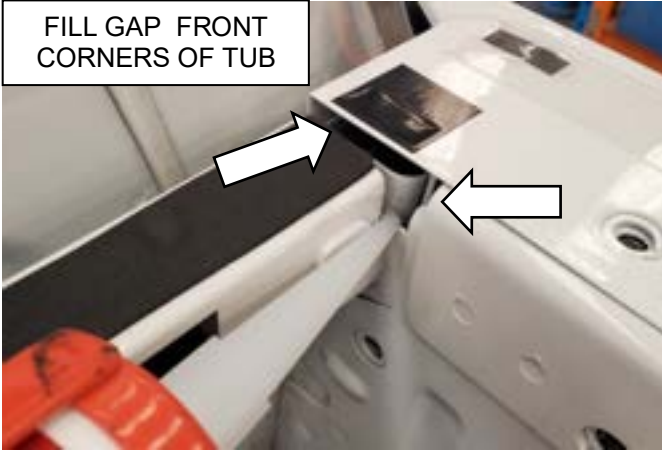

MAKE SILICON
SMOOTH AND NEAT



PLACE X2 SILICON
BUMP STOPS

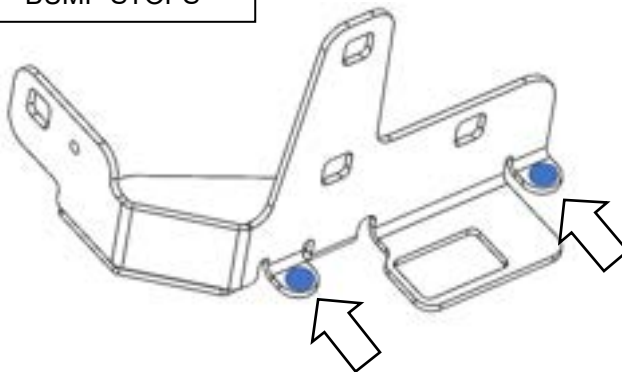

4.7) **Spray the tub with a water film. Apply clear neutral cure silicon to fill the gap under the front corner of the front tub rail and front corner holes on both sides to obtain a water seal**

4.8) **Use clear neutral cure silicon to fill the gap between the tubs' front rail and side tub rails.**

Make smooth and neat, wipe off any excess and allow it 10mins to skin cure.

Do both sides of the tub.

!! IMPORTANT !!

The above steps are imperative to ensure the tub is water sealed in the front tub corners.

4.9) **Take front tub corner mounting brackets (668PD167R/L) and place two bump on clear circular pads (665076) to the tags on the brackets as shown.**



4.10) Take rear tub mounting brackets (668PD157R/L) and place one bumpon (665076) to the tag on the brackets as shown.

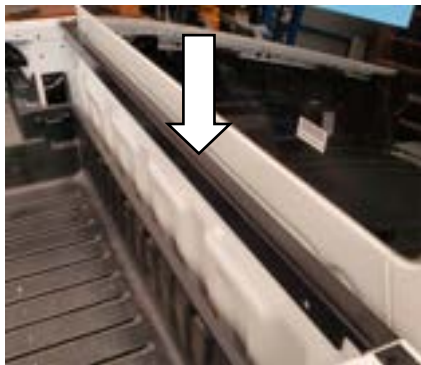

4.11) Place the front mount rail bracket (668PD156) over the front tub rail. Align the bracket to center and align it with the with threaded holes in the front face of the tub on each side. Ensure there is an even gap between the ends of the bracket to the side rails of the tub.

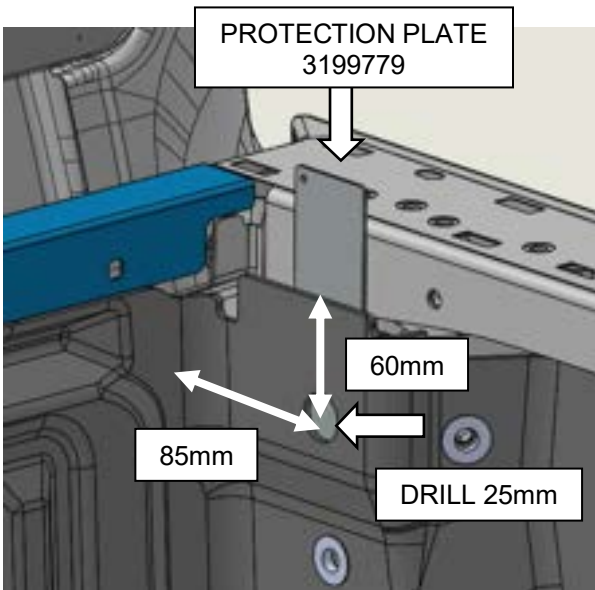

4.12) **If the tub is fitted with a XL or XLT bed liner**, a 25mm diameter hole will need to be drilled. Measure 60mm down from top edge of the bed liner and 85mm from front inner face of liner. Place the steel protection plate (3199779) behind liner taped with masking tape to the sheet metal at the top to the protect tub from the drill. This hole will be used to gain access to the M8 threaded hole behind to allow fitting of the front corner bracket in the next step.

Do both sides of the bed liner.

TIGHTEN TO 20Nm



4.13) Locate the front corner mounting brackets (668PD167R/L) to the front corners of tub.

Per bracket, take four M8x25mm Torx screws (6151625), with M8x19x1.2 washer (4581085) and finger tighten these through the bracket to the tub first.

Press down on the front corner bracket to ensure the tags (with the bumpons fitted), engage the top faces of the side rails of the tub. Ensure the 668PD156 front mount rail is level to the top of the side tub rails. Once in place tighten all screws to 20Nm.

DRILL 5MM THRU HOLE



4.14) Drill a 5.2mm hole through the existing hole in front corner mounting bracket where it meets the front tub rail and drill through the front tub rail.

APPLY RUST INHIBITOR TO HOLE



4.15) Apply rust inhibitor 665505 to drilled hole.

INSTALL RIVET
6609087



4.16) Install rivet (6609087) to the drilled hole.

Do this on both sides of the tub.



4.17) Use an alcohol wipe (6602018) to clean away rust inhibitor residue.

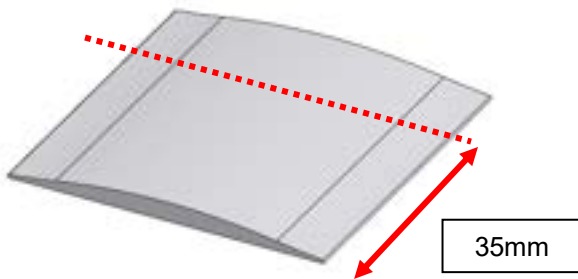

4.18) Cut a pair of rubber tub bridge seals (668PM005) down to 35mm width as shown.

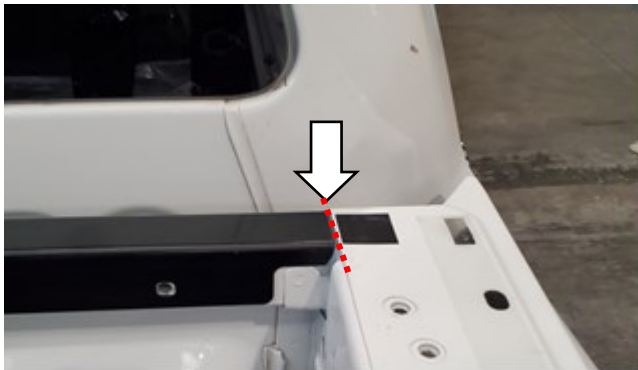

4.19) Apply neutral cure silicon to the ends of the front mount rail bracket both sides, to fill the gaps between the bracket and the side tub rails.
Clean surrounding surfaces well using an alcohol wipe (66020018) to remove silicon from surrounding surfaces at the join.



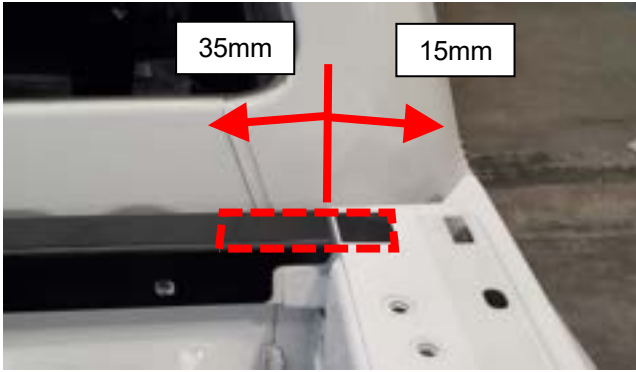

4.20) Follow the directions written on the primer stick (665044) prime the front mount rail and the tub over the black sticker, to the width of the front header rail bracket to 15mm onto the side of the tub and 35mm onto the front header rail bracket.

Do this on both sides

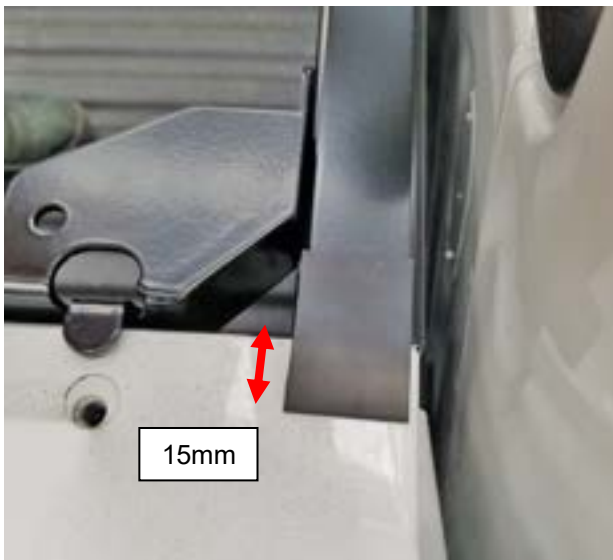

4.21) Apply to either end on top of the front mount rail the cut down bridge seal (668PM005), by removing the backing paper off the adhesive side and sticking it down to the dimensions shown opposite (**15mm overlap only to the side tub rails**), ensuring its rearward facing edge is up against the front leading edge of the front corner bracket. **The ramp curved profile should go between the front header rail and the side of the tub as a "bridge"**.

!! IMPORTANT !!

POSITION THE SEAL BRIDGE EXACTLY AS SHOWN OR FRONT CORNER WATER LEAKS COULD OCCUR

APPLY SILICON TO EACH SIDE OF BRIDGE FRONT AND BACK



4.22) Apply clear neutral silicon to the edges of bridge seal as shown. Wipe clean and make neat.

REMOVE SCREW

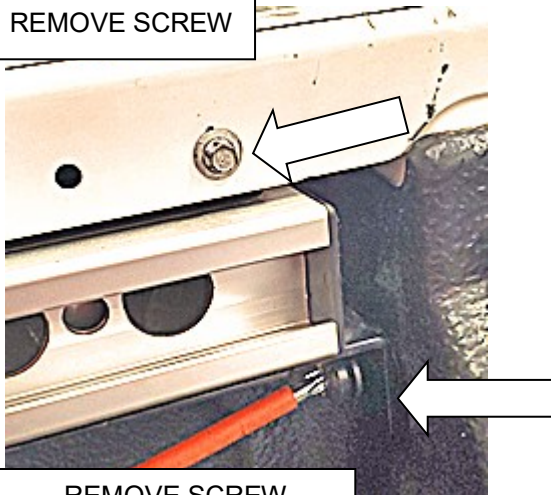

REMOVE SCREW

4.23) If CMS cargo tie down rails are fitted, on the right-hand rear corner of the inner tub lip, remove the top screw and discard it.

Under the rear bracket of CMS rail use a T40 torx drive to remove M8 screw and discard the lower screw.

Repeat on opposite side of tub.

6152008
M6 SCREW TO 9Nm



INSTALL T40 TORX M8
SCREW TO BOTTOM
BRACKET

4.24) If CMS cargo tie down rails are fitted, locate the rear tub mount bracket (668PD157R) over tub lip where the tag with bumpon engages the top face of the side tub rail **and push down so it engages on the bumpon** and the lower end of the bracket meets up to the face of the bracket supporting the CMS track.

4.25) Use T40 Torx M8x35mm screw (6151881) and washer M8x19x1.2mm (4581085) and install them to the bottom threaded hole. **Tighten to 20Nm.**

4.26) Use Hex flange head M6x25 screw (6152008) and washer M6x20x1.2mm (4581082) on top hole in the bracket and **tighten to 9Nm.**

Do both sides.

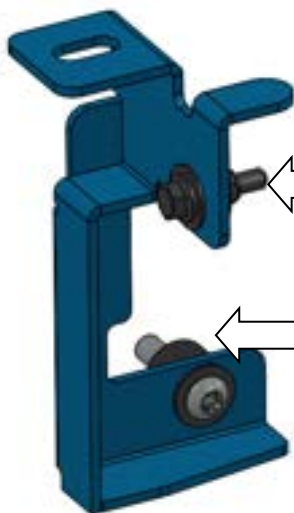

M6 SCREW 2
WASHERS AND
A NUT

SPACER
6253421

4.27) If the CMS cargo tie down rails are **NOT present** in the tub, use the 20mm x 13.5mm thick spacer (6253421) for bottom bracket fixing hole to the rear tub pillar. **Tighten to 20Nm.**

4.28) At the top of the bracket use Hex flange head M6x25 screw (6152008) and washer M6x20x1.2mm (4581082) on top hole in the bracket and on the inside of the tub lip fasten with washer M6x20x1.2mm (4581082) and M6 nyloc nut (6151223) **and tighten to 9Nm.**

Do both sides.



4.29) View the side with the spigots of the plastic spacer locators tub rail (668PE051R/L) and cut off spigots as marked on underside of spacer.

“M” (for middle position)

Cut all other pins off, other than pins marked “M” for the middle spacer position.

“R” (rear position)

Cut all other pins off, other than pins marked “R” for the rear spacer position.

Ensure pins are cut below the side profile height of the spacers so they sit flat on top of tub.

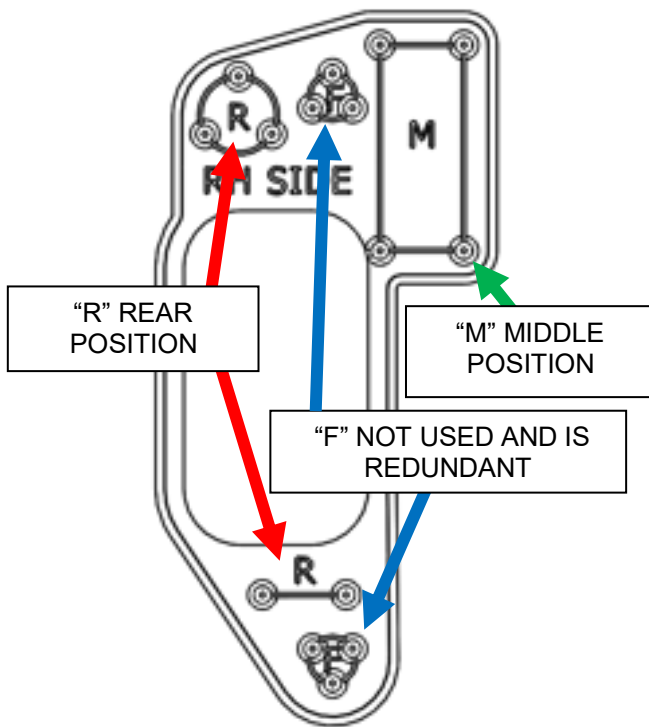

LH TOP TUB RAIL SHOWN



M LOCATOR AND SPACER POSITION AT MIDDLE OF TUB



R LOCATOR AND SPACER POSITION AT REAR OF TUB

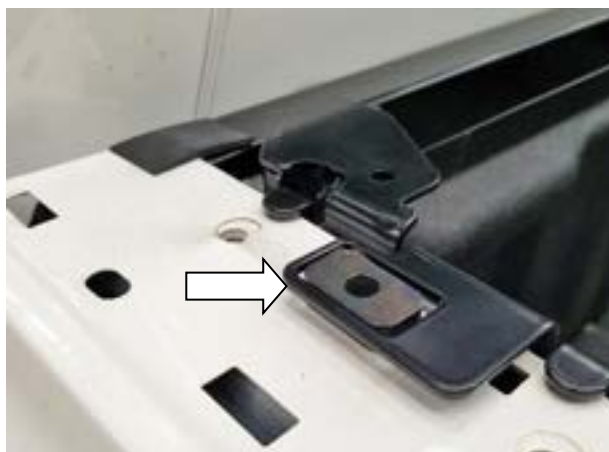

668PD161 SPACER LOCATED THROUGH TOP OPENING OF 668PD167L BRACKET

- 4.30) Once the spigots have been cut off and per position location on the tub (Middle or Rear), place spacer locators 668PE051R/L along tub lip (2 LH parts to LH tub rail and 2 RH parts to RH tub rail top surfaces).
- 4.31) Position these Middle and Rear. See images. The spigots on the locators locate into existing holes in the tub corresponding to their position on the tub.
- 4.32) Then place inside 668PE051R/L spacer locators a total of 4 (668PD151) rectangular spacers that are 10mm thick.
- 4.33) Through the front corner mount brackets (668PD167R/L) place of 2 (668PD151) rectangular spacers that are 10mm thick.(1 per side).



SEPARATE LH AND RH
FOAM PADS

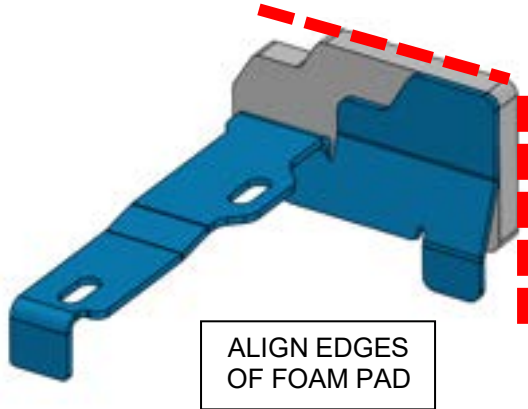

ALIGN EDGES
OF FOAM PAD

- 4.34) Separate the foam tape pad 668PB032 in half. Remove the backing paper on one side.
- 4.35) Adhere RH and LH foam pad to rear corner tailgate sealing bracket (668PD159R/L) respectively.
- 4.36) Align top edge and inner edge of bracket with foam pad as shown.

SECTION 5.0: FITTING THE CANOPY WIRING LOOM

5.0) General view of the canopy to vehicle patch wiring harness routing for 668PJ033.

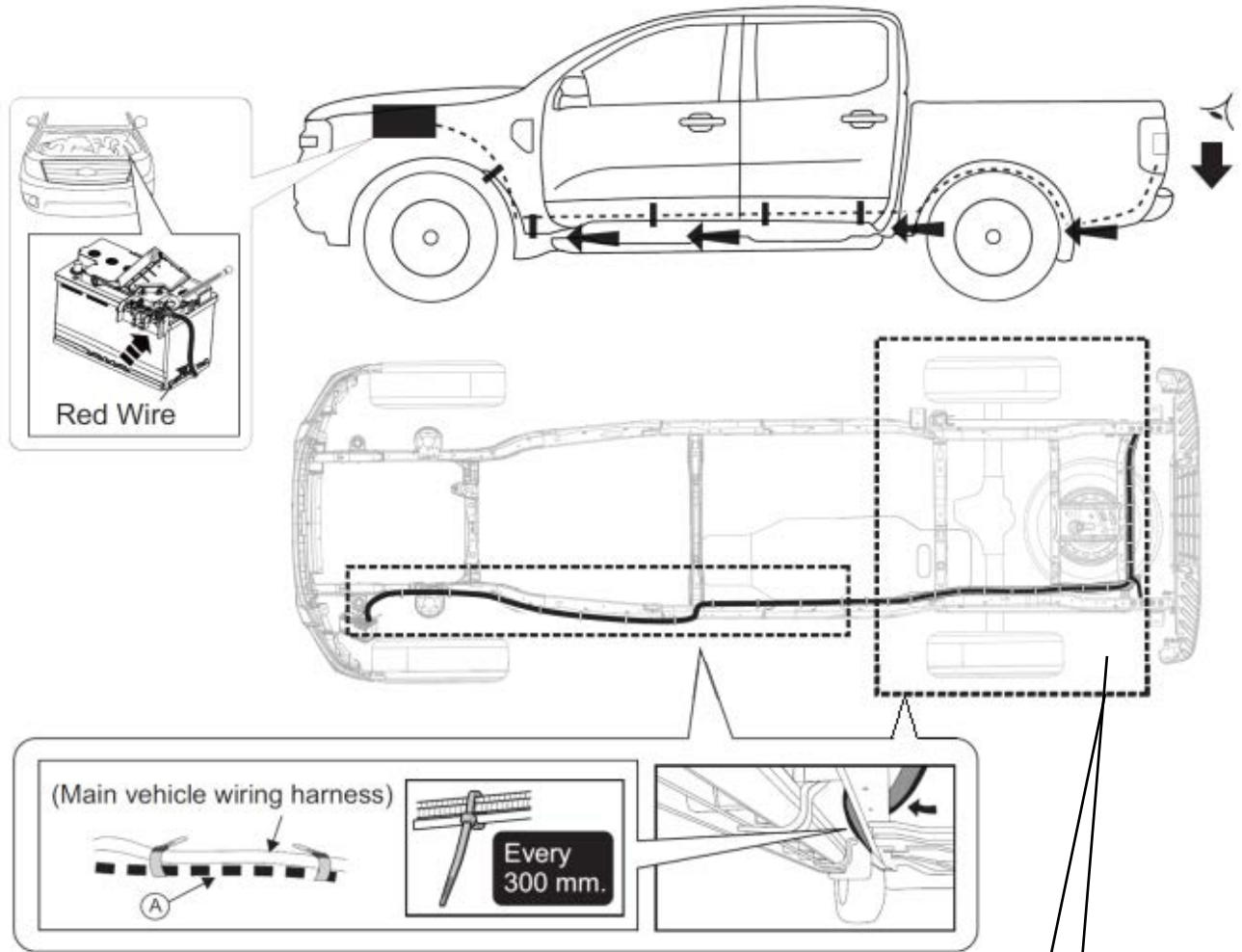

5.1) Specific requirement **only for** Ford Ranger PHEV Hybrid vehicles (From rear of cabin to rear of vehicle).

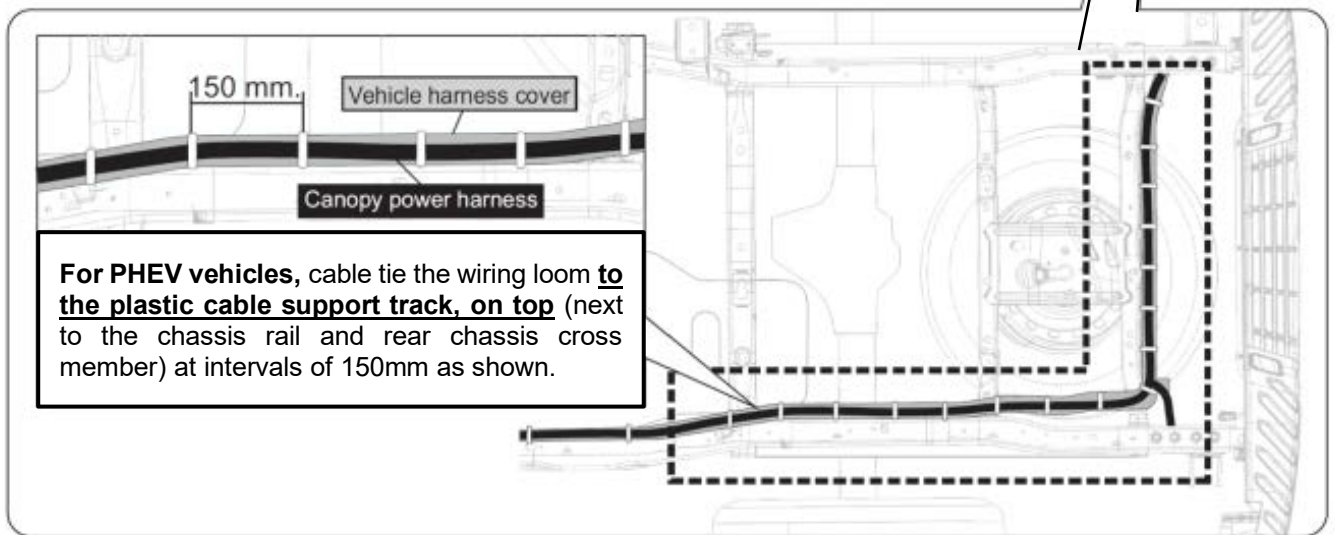



Battery Engine Bay

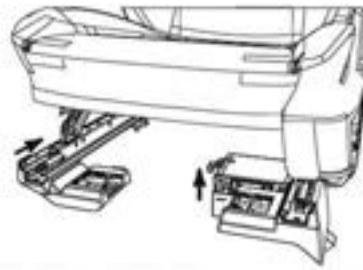

Front Passenger Seat

5.2) Begin by removing the negative terminal on the battery in the engine bay. For PHEV check if it is equipped with an auxiliary battery under the passenger seat by sliding the seat backwards. Disconnect the negative terminal also on this battery.

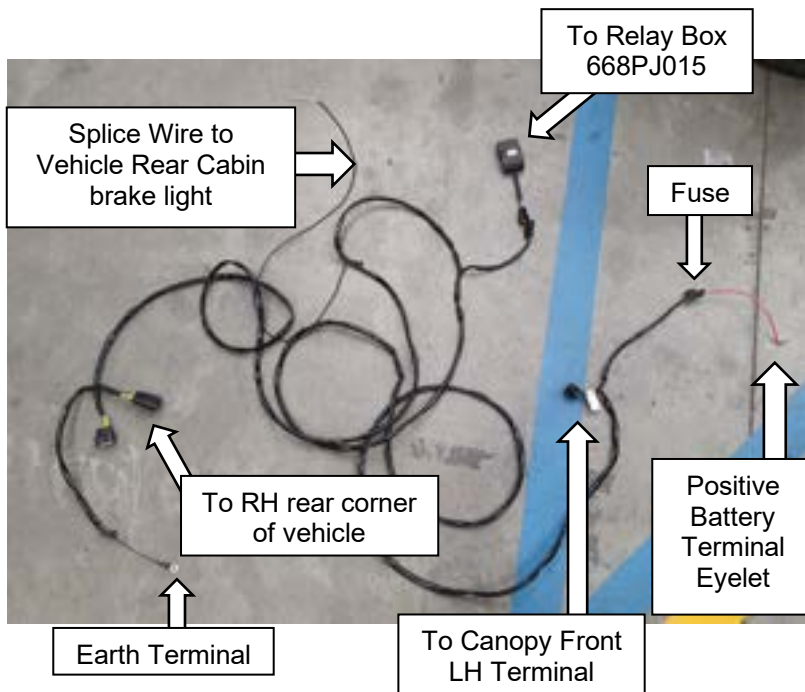

5.3) Unpack the canopy's wiring loom patch harness (668PJ033) and locate the pair of connectors to that go to the RH rear corner of the vehicle.



DISCONNECT 16 PIN ELECTRICAL CONNECTOR

5.4) Put the car on hoist and start at the underside rear RH corner of the chassis rail.
5.5) Locate and disconnect the 16 pin OE connector as pictured.



5.6) Connect the (668PJ031) canopy loom between the two vehicle's connectors.

ON XL,XLS,XLT, WILDTRACK



FASTEN EARTH TERMINAL TO EXSTING M6 SCREW ON CHASSIS RAIL TO OUTSIDE

ON RAPTOR



FASTEN EARTH TERMINAL USING M6 SCREW FROM KIT ON CHASSIS RAIL TO INSIDE

5.7) **ON XL, XLS, XLT, WILDTRAK ONLY** Locate the earth screw on RH chassis rail on the outside of the rail and undo it with an 8mm socket. Reinstall the M6 screw with earth eyelet attached from the 668PJ031 canopy loom.

5.8) **ON RAPTOR ONLY** Locate the M6 weld nut on the inside of the RH chassis rail next to the spare tyre. Install (6152008) Hex flange head M6x25 screw through the earth eyelet on the 668PJ031 canopy loom and secure it to the chassis rail and **torque to 9Nm.**

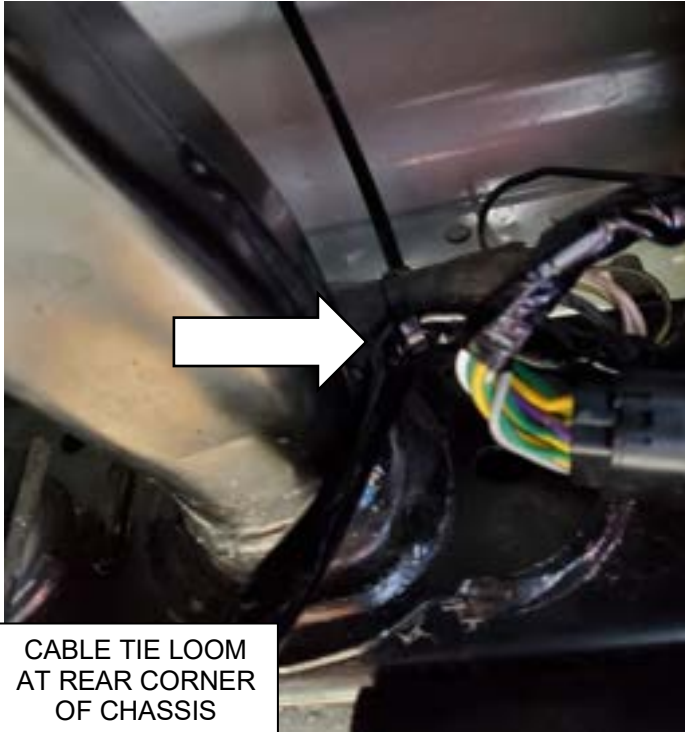

CABLE TIE LOOM AT REAR CORNER OF CHASSIS

5.9) Use a cable tie (180302) and tie off the canopy loom to the vehicle's loom at the RH corner of chassis where the cross member goes across the vehicle.



CABLE TIE LOOM ACROSS CHASSIS

5.10) Follow the vehicle loom across the width of the vehicle's chassis to LH side behind the spare tyre and cable tie the canopy loom to it before the spare tyre.



5.11) Cable tie off canopy loom to the vehicle's loom above the spare tyre and at the chassis junction of the cross member to the LH side chassis rail (2 cable ties used).

CABLE TIE LOOM ACROSS
LH CHASSIS RAIL



5.12) On inner side of LH chassis rail, locate the vehicle's wiring loom and lead the canopy loom towards the front of the vehicle and cable tie in two places rearward of the LH rear wheel bump stop.

Do not tie cable ties to brake lines.

PASS LOOM THROUGH TO
OUTSIDE OF CHASSIS RAIL



5.13) Cable tie off the canopy loom again at 3 places to the vehicle's wiring loom before it reaches the location where the vehicle's loom crosses over the top of the LH chassis rail.

CABLE TIE LOOM ACROSS
LH CHASSIS RAIL

5.14) Pick up vehicle's loom on the outside of the LH chassis rail and secure the canopy loom to the vehicle's loom with a cable tie at the bend.



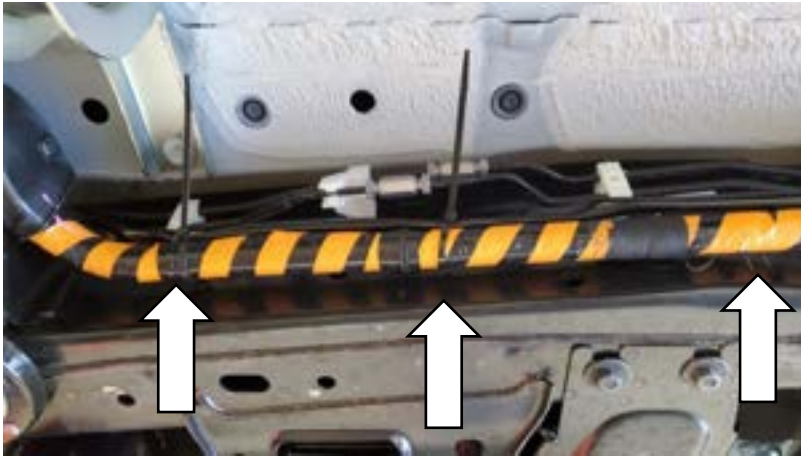

5.15) Cable tie off the canopy loom with 3 more cable ties to the vehicle's loom as it heads forwards towards the plastic cable track behind the front LH wheel near the body mounting.



5.16) Pass the canopy loom between the chassis rail and the body floor (behind the body mount), ensuring all forward connectors and fuses are orientated to fit through the cavity.



LEAD LOOM BEHIND LH FRONT WHEEL ARCH LINER

5.17) Lead the canopy loom through to the front LH front wheel arch liner and cable tie off to vehicle's main loom at the bottom



5.18) Open the bonnet and thread the canopy loom up through behind the LH wheel arch liner to the front corner of engine bay, behind the fuse box.



5.19) Push loom down as far down as possible behind the fuse box and pull it forward to the cavity between the battery and the fuse box.

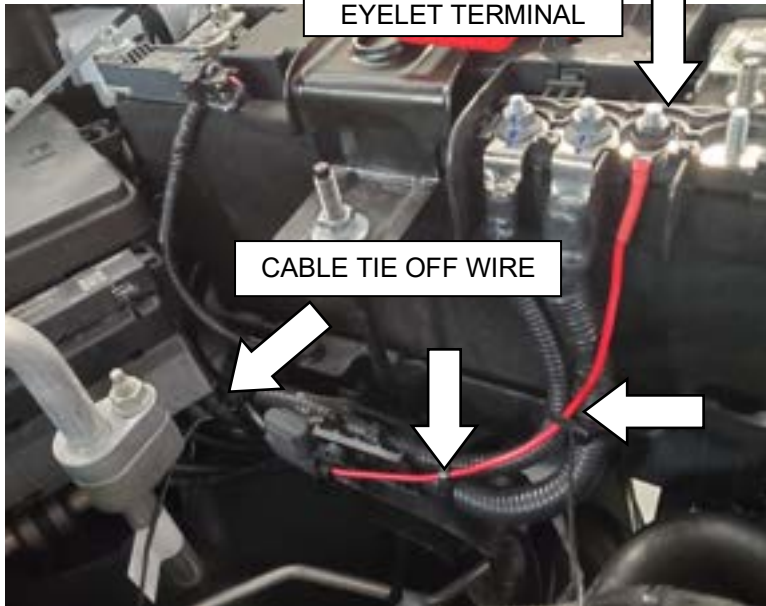

5.20) Locate the positive battery terminal under the red plastic cover and connect the 6mm eyelet on the red wire of the canopy loom to the third battery terminal.

Use the M6 flange nut (6151173) to secure the eyelet to the battery.

5.21) Cable tie off the loom to the vehicle loom conduit with cable ties in 3 places.



5.22) Use (668PB015) anti-rattle foam strips and apply in the two positions shown on the (668PJ015) latch relay.

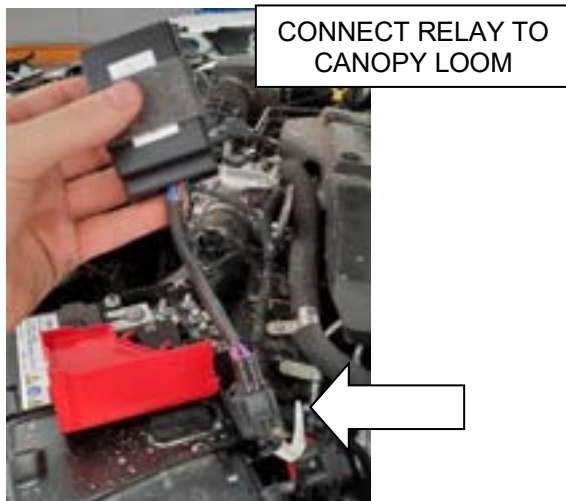
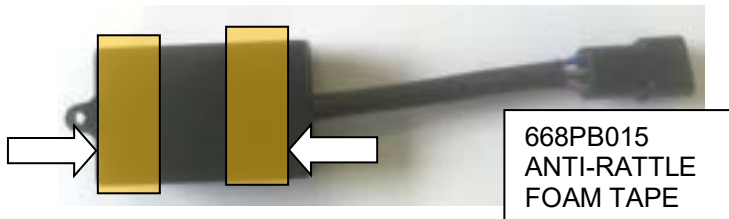

5.23) Connect (668PB015) relay box to the canopy wiring harness at connector.

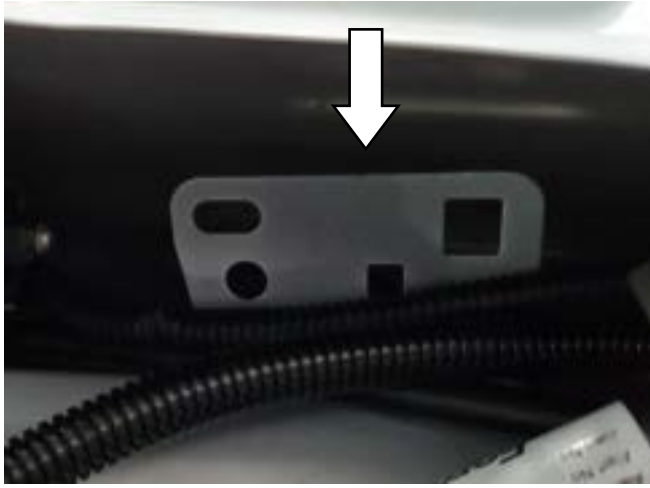

5.24) Locate the vehicle's bracket under LH lip of the front fender. This will be used to tie off the relay box to.



5.25) Loop a cable tie through hole in one end of the relay box.

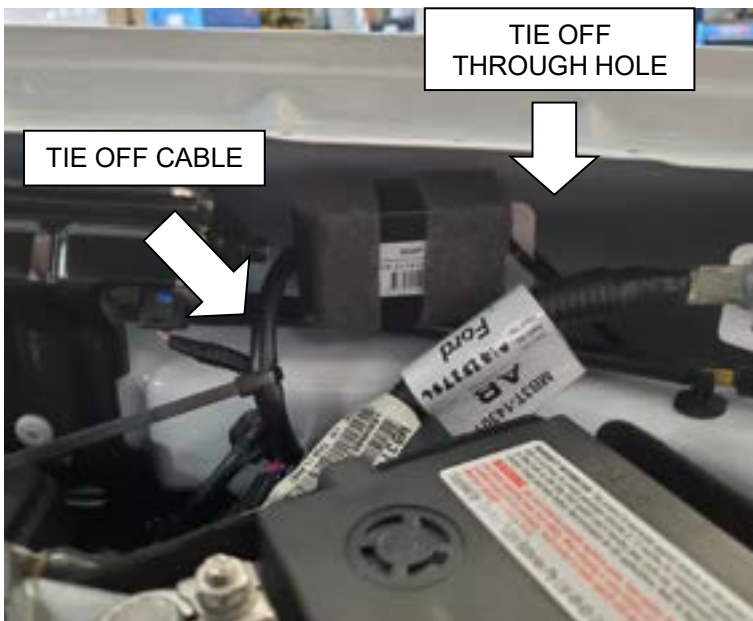

5.26) Locate bracket under the LH front fender. Cable tie the relay box to the bracket and to the vehicle's wiring harness.

5.27) Tie up any excess cable length in the rear corner of the engine bay behind the fuse box and secure it with a cable tie to the vehicle's loom.



5.28) Locate the interior left hand rear door scuff moulding and remove it. Locate the vehicle's wiring loom and carefully remove sheathing to expose the wires.

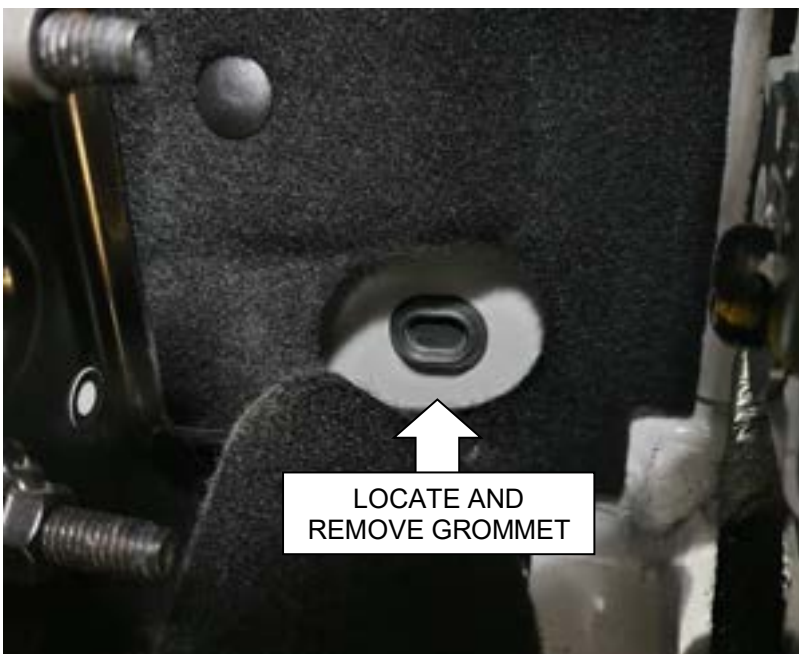

5.29) Behind the left-hand rear seat, locate the rubber grommet. Remove and keep it.

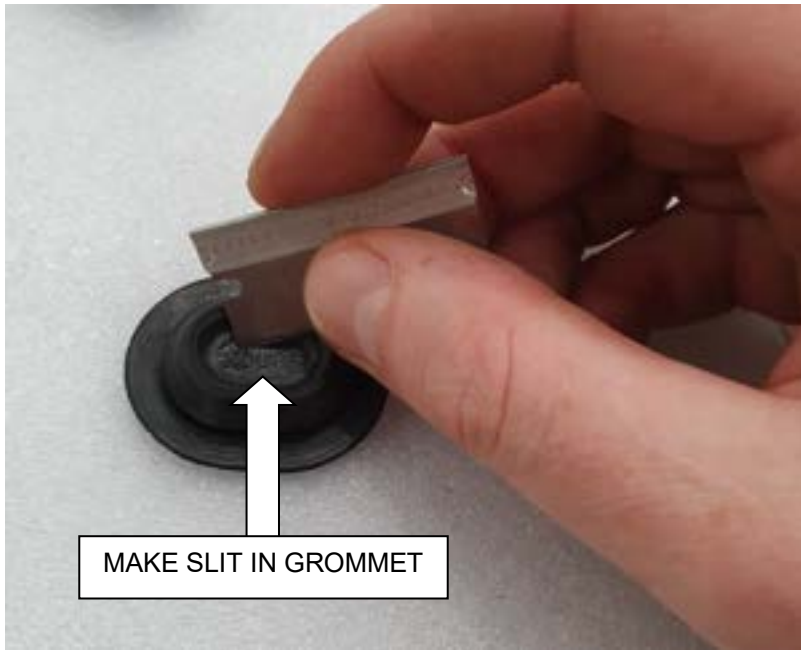

5.30) With a knife make small slit in centre grommet. This will be used to thread wire through.



5.31) Locate the brake light wire on canopy loom and push up between the tub and the rear of the cab until it locates over the grommet hole in the back of the cabin. You will be able to feel with your fingers when it is located.

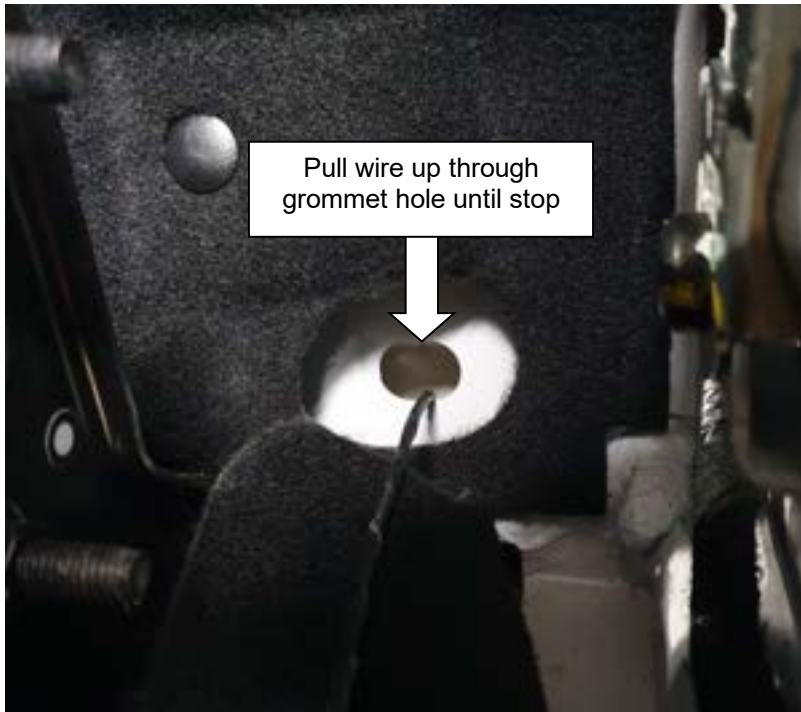

5.32) Thread the canopy loom brake light wire through grommet hole until taugt.



5.33) Thread the wire through the grommet.

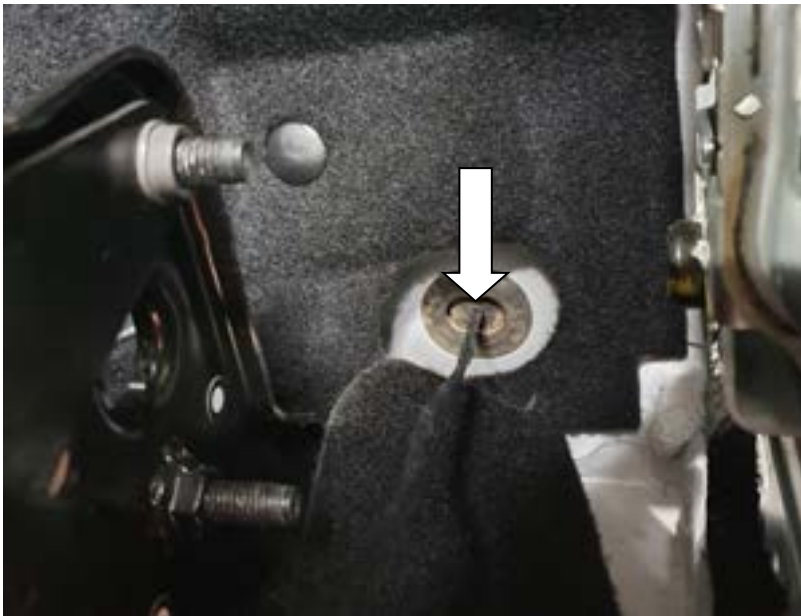

5.34) Pull the wire through the grommet until taught and reinstall the grommet back into the sheet metal hole.

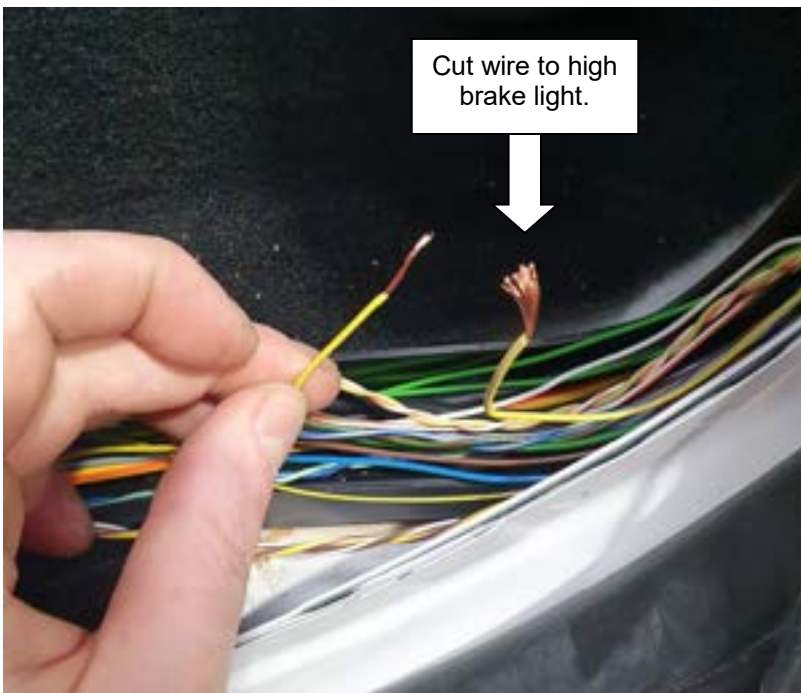

5.35) Locate wire that leads up to high mount brake light on the cabin inside the vehicle's loom at the rear door area and cut and strip the wire ends.

(Yellow / Grey striped wire) is required to be cut.

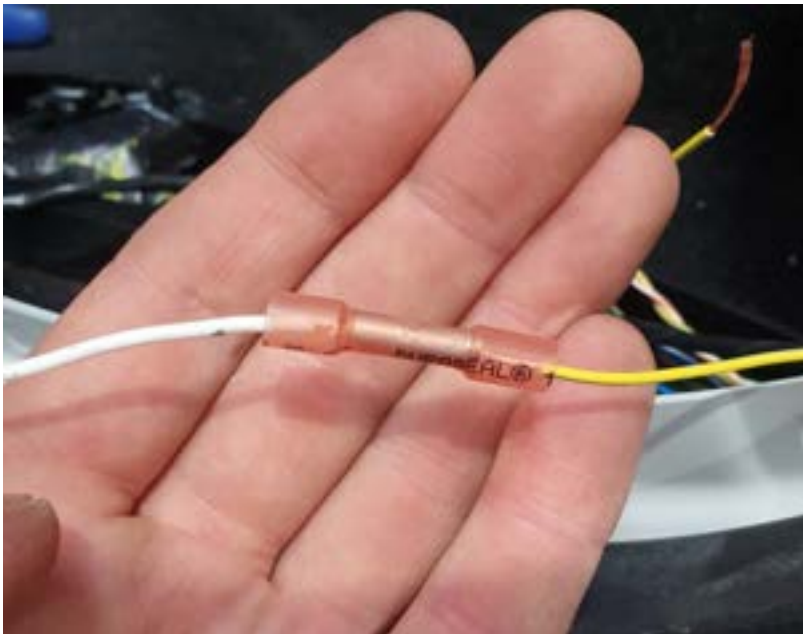

5.36) Take stripped end of canopy loom wire and stripped active end of the vehicle loom brake light wire leading to high mount cabin stop lamp. Use a splice connector to crimp the wires together and heat shrink them. Or solder and heat shrink.

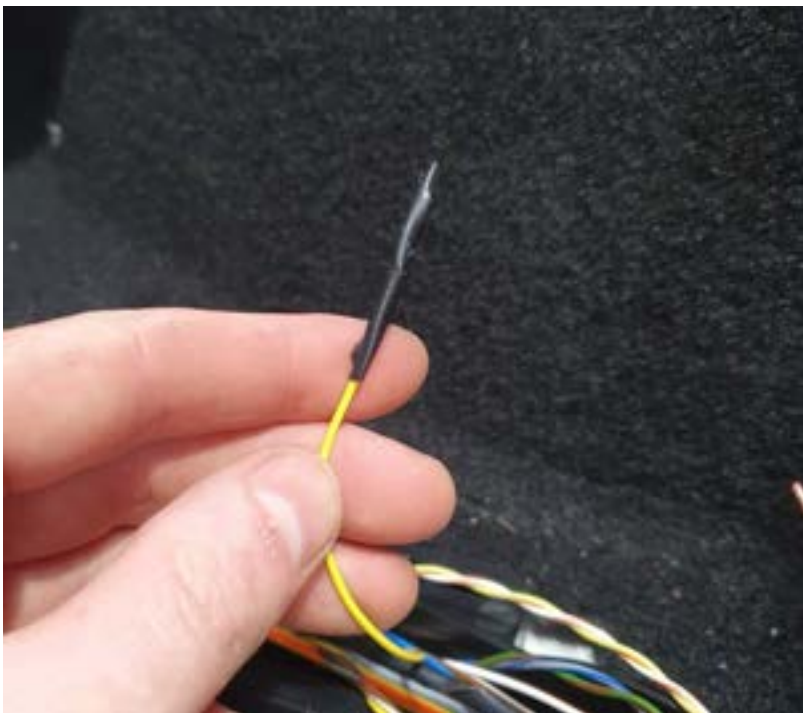

- 5.37) Terminate the defunct vehicle brake light wire at the rear door with electrical tape.
- 5.38) Tuck wires back into vehicle loom cavity and reinstall the vehicle plastic door scuff plate.
- 5.39) The loom is now fully installed.
- 5.40) **Reconnect the vehicle's negative battery terminal on PHEV (if fitted) also reconnect the negative terminal on the auxiliary battery under the passenger seat on PHEV.**
- 5.41) **Test the brake light function and the canopy spoiler brake light operates while the cabin mounted brake light on the vehicle should now not operate.**

SECTION 6: FITTING THE CANOPY

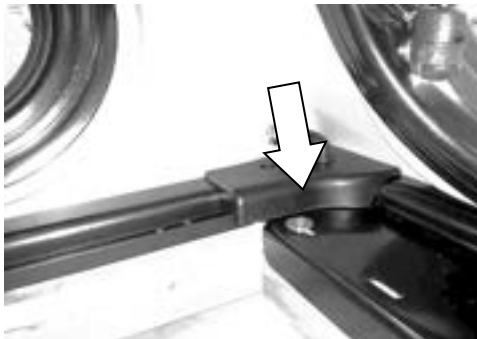
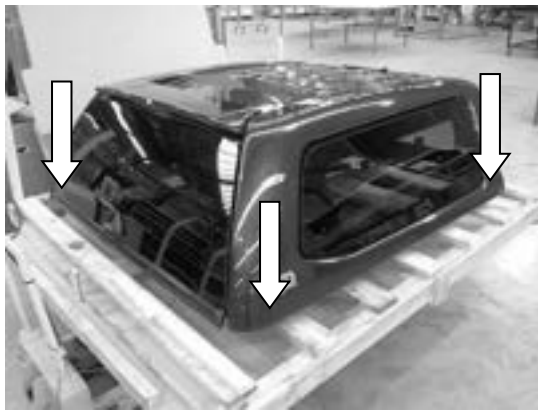

- 6.1) Unscrew the canopy on the pallet by removing the 4 wood screws in each corner. Gain access to screws via opening the rear door and front lift up window
- 6.2) The front lift up window can be unlatched by reaching in underneath the canopy on the pallet and pushing forward on the glass in car position, to push the latch button upwards on both latches to unlock the window.



- 6.3) Clean the front window of the canopy on the outside.
- 6.4) Clean the rear window of the vehicle's cabin.
- 6.5) Close the vehicle's tailgate.



- 6.6) Cut the cable tie holding the wiring harness to the window frame bracket inside the front corner of the canopy. Using masking tape, tape the harness up over the front LH corner of the canopy.

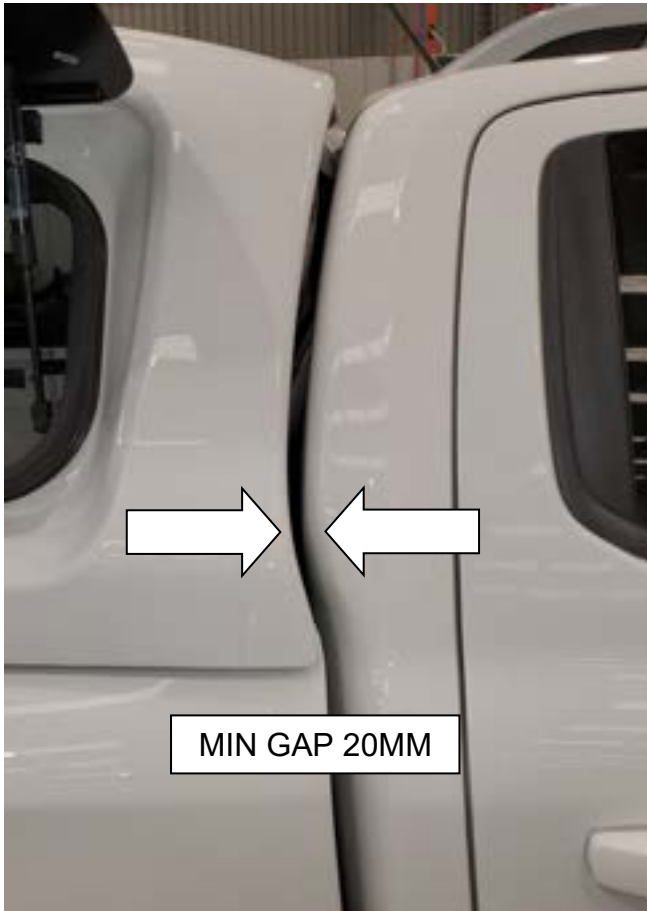

TOP VIEW OF FRONT CORNER OF CANOPY ON VEHICLE

Front lower trim edge of shell to align to edge radius at front of tub

Vehicle tub front corner

Canopy shell

6.7) Close the canopy's rear door and **USING 4 PEOPLE**, lift the canopy from the pallet and place it carefully down onto the vehicle's tub

Be careful not to dislodge the foam tape around the inside edge of the canopy shell's lip perimeter.

Take care during this process to ensure the trim edge of the canopy shell is lowered down evenly and is not contacting the vehicle tub to avoid paint damage.

When re-positioning the canopy, lift the canopy up to avoid dislodging the weather seal underneath.

POSITIONING OF CANOPY ON TUB:

The canopy should be positioned so the lower door edge's sash seal is sealing well and evenly along its length to the tailgate door stop extrusion assembly mounted on the vehicle's tailgate and even side to side so the tailgate closes with clearance between the door frame seals at the sides of the canopy.

Then review the front leading lower edge corners of the canopy are aligned just to the beginning of the edge radius at the front of the tub.

Check minimum gap from canopy front pillars and cabin is 20mm at the tightest location on the hip of the front pillar of the canopy to the vehicle's cabin.



6.8) Measure the trim edges of the canopy at the rear sides and at the front both sides, to the vehicle's tub.

This measurement should be even on both sides of the canopy.



6.9) Stand back and walk around the canopy and check uniform balanced fit to the tub and cabin.

- The canopy is central on the Ute body.
- Alignment between cab and canopy is even both sides
- The rear door seals against the tailgate door sealing stop evenly both sides without excessive force on glass to close.
- The gap is even between the door and shell on both sides.

M8x35 Torx screw (6151881) with M8x25x3mm washer

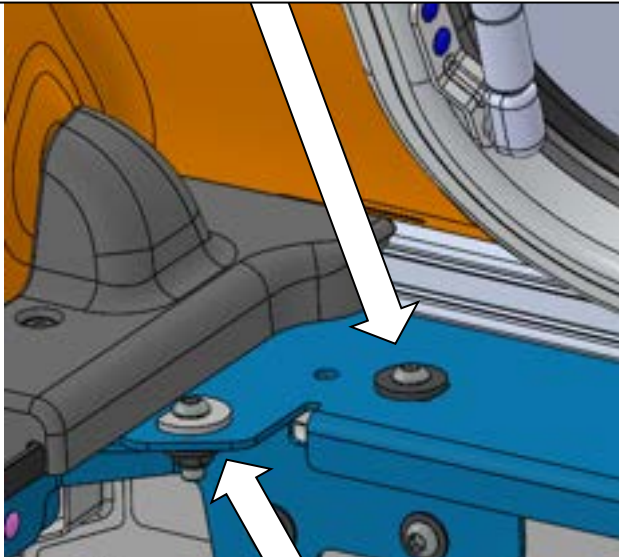

M8x25 Torx screw (6151625) with M8x 28 flat sided washer (668PD170) above and M8x 25x3mm washer (4581303) below with M8 Nyloc nut (6151212)
If no 668PD170 in kit, use 4581303.

6.10) In the front corner of the canopy assemble one M8x35mm torx head screw (6151881) with one M8x25.4x3mm thick washer (4581303) and fasten it down through the canopy's base rail. If there are no 668PD170 in kit, use 4581303 washers instead.

On the inner edge of the front corner of the base rail, assemble one M8x25mm Torx head screw (6151625), one M8x25x3mm washer (4581303), one M8x28x3 flat sided washer to the front tub mount bracket (668PD167R/L) and M8 nyloc nut (6151212)

Tighten M8 screws to 20 Nm.

Do for both sides.

M8x35 TORX
SCREW(6151881) WITH
3MM THICK WASHER



M8x25 TORX SCREW
(6151625) WITH 3MM
THICK WASHER

6.11) In rear corner assemble one M8x35mm screw (6151881) with one M8x25.4x3mm thick washer (4581303) and fasten it down through the back corner of the canopy's base rail.

Tighten to 20 Nm on both sides.

On the inner edge of the rear corner of the base rail, assemble one M8x25mm torx head screw (6151625) with one, M8 3mm thick washer (4581303) to rear tub mount bracket (668PD157R/L) – do not add bottom washer of nyloc nut yet.

REMOVE M6 NYLOC NUT
UNDERNEATH HERE TO INSTALL
TAILGATE SEAL BRACKET



6.12) Locate outer most M6 nut and bolt assembly on door frame lower bracket and remove bottom M6 nyloc nut and washer. Discard the nut.
Do this on both sides.

M6 NYLOC NUT



668PD159L BRACKET

M8 NYLOC NUT
M8 WASHER 3MM
THICK

6.13) Take rear tub tailgate corner sealing bracket (668PD159R/L) (RH shown) and place it under the canopy's base rail and align the bracket's slots with the M6 and M8 bolts.

Loosely assemble a new M6 nyloc nut (6151223) with the retained washer and an M8 nyloc nut (6151212) and M8x25.4x3mm thick washer (4581303) to the underside of the (668PD159R) bracket and allow bracket to move freely back and forward.

Do this both sides.

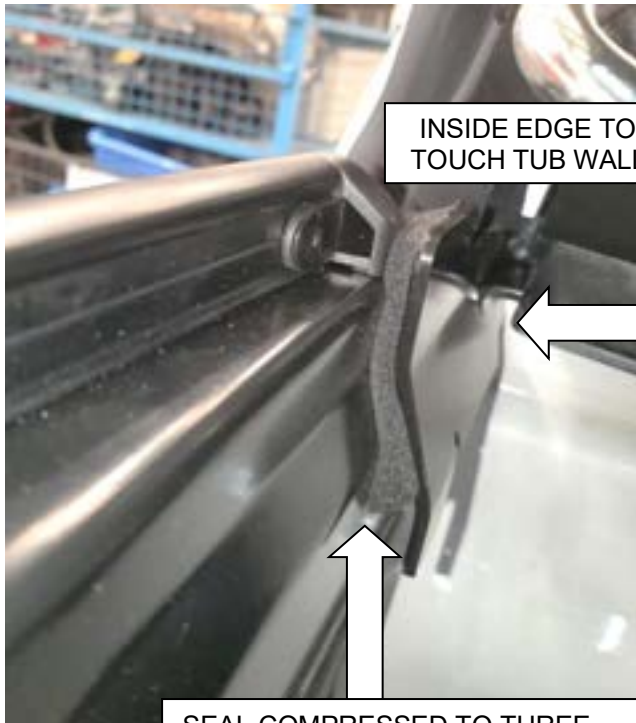

SEAL COMPRESSED TO THREE QUARTER THICKNESS

6.14) Close vehicle tailgate and pull THE rear tub corner sealing bracket (668PD159R) against the tailgate door stop assembly until the sealing foam is compressed to three quarters of the expanded thickness.

Make sure the inside edge of the foam seal is touching the inside vertical wall of the tub wall.

6.15) When bracket is in place tighten both screws.

**M6 nyloc to 9 Nm.
M8 screw assembly to 20 Nm.**

Do both sides.



SLOT TAB INTO TOP OF SEAL CAVITY

6.16) **If a Wildtrak bed liner is installed on the tub, locate the tailgate rubber bulb seal (where it was cut in fitting instructions 37801115) and slide it up on lower tabs of the rear corner sealing brackets (668PD159R/L) to meet up to the foam sealing pads on the brackets.**

M8 NUT PLATE 668AQ026

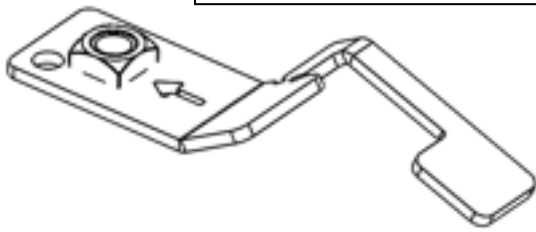

INSERT NUT PLATE INTO WINDOW LATCH COVER SLOT

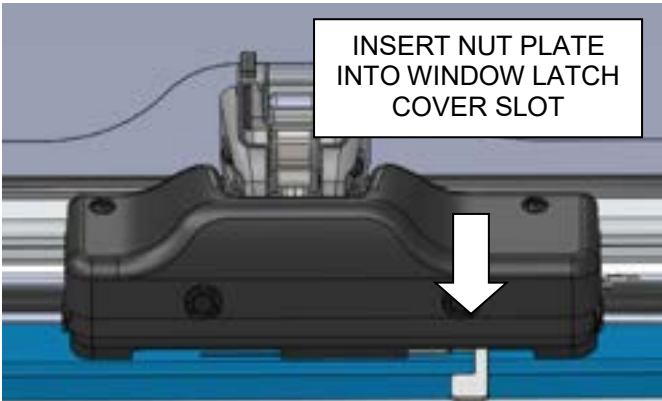

(6151681) M8 x 35 HEX BOLT
(4581085) M8 FLAT WASHER

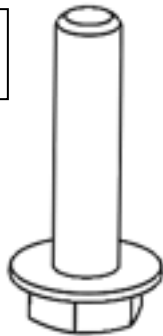

USE EXTENSION SOCKET TO THREAD M8 SCREW THROUGH TUB INTO M8 NUT PLATE

6.17) The middle length fixing of the canopy on both sides, requires nut plate mid mount bracket (668AQ026)

6.18) Using the break-away tab arm, push the nut plate into the slot underneath the side window lock mechanism cover ensuring not to pinch wiring inside during this process. If in doubt, remove the top cover over the latch mechanism to improve visibility for assembly.

Rear slot is used for the position of the nut plate for each side of vehicle.

6.19) With 13mm socket and extension, locate the corresponding hole under the side tub rails, with M8 nut plate (668AQ026) slid in position (per the above step), screw the M8x35 hex head screw (6151681) with an M8x19x1.2 washer (4581085) into the nut plate (668AQ026) from underneath the side tub rail.

Keep the nut plate square to the canopy base rail on the inside by using a flat blade screw driver to hold it in place against the lock mechanism cover and tighten the bolt to 20 Nm.

6.20) **Once assembled, break off the protruding arm for the nut plate (668AQ026).**

Do both sides.

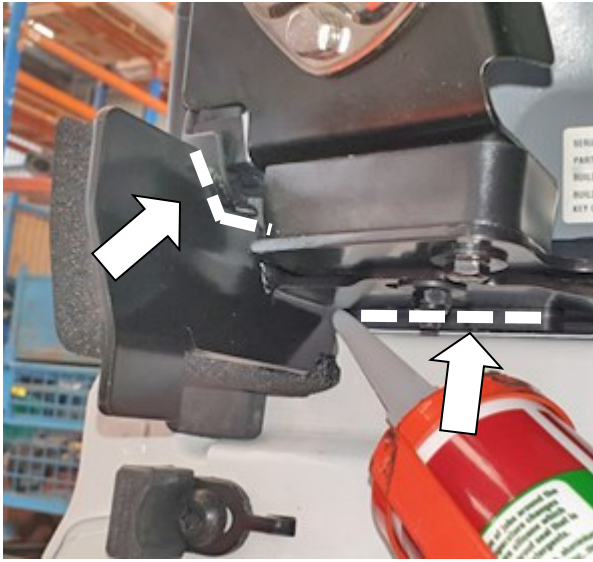

6.21) Behind the tailgate sealing bracket, between the base rail and the tub rail rear area, use neutral cure clear silicon to fill cavity at this point and also where the foam seal contacts the plastic corner piece.

6.22) Clean off excess silicon and make neat.

Do both sides.

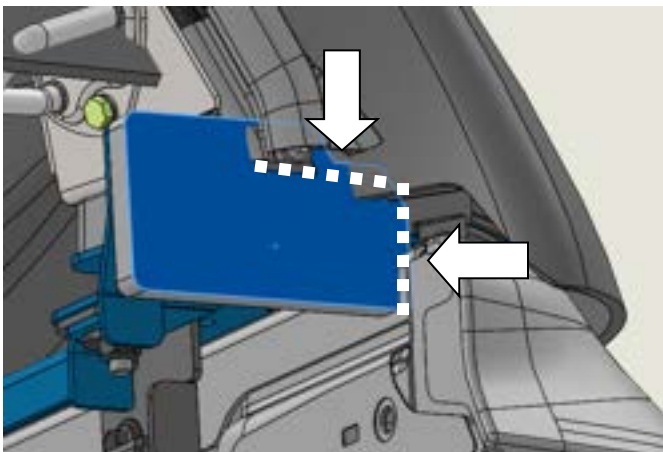
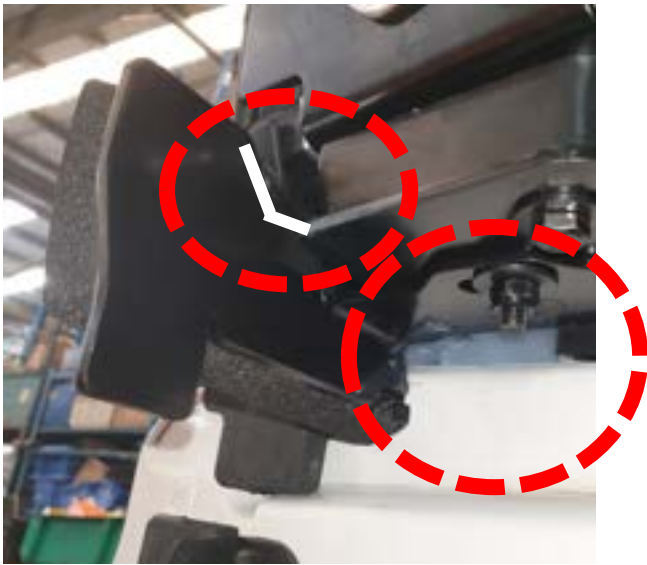

6.23) Use clear neutral cure silicon to close the gap between top of foam tailgate seal and plastic corner pieces mouldings of the canopy. Also run silicon down between the vertical corner edge foam seal and the tub side wall.

See more pictures on the next page.



Note: Silicon is to run behind rubber corner block seal (668PE057R/L).

Clean up excess and make silicon neat.



6.24) Cable tie the (6821293) cable tie base to the canopy loom at the front LH outer corner of the canopy, in the location shown (on the base of the rubber grommet) tight enough to not allow it to fall down the loom and in the orientation shown.



6.25) Reaching between the tub and cabin on left hand side with an alcohol wipe, clean an area on the front of the tub level to where the cable tie base will be fitted.

6.26) Peel the protection film off the cable tie base (6821293) and drop the canopy loom down between the cabin and tub on the LH side.

6.27) Reaching in between the cabin and the tub, press the cable tie base firmly onto the front of the tub and ensure it has adhered firmly.



6.28) Connect the canopy wiring connector to the end connector of the canopy wiring harness (668PJ031) fitted to the vehicle, in the plenum above the LH chassis rail forwards of the LH rear cabin body mount.

6.29) Cable tie the remaining harness up in the cavity and tie it off to the vehicle's main wiring loom.

6.30) **Press the key fob of the car to the UNLOCK POSITION TWICE.**

6.31) Go to the canopy's rear door and press the door push button pad. Check the door opens and the electric actuator functions to unlock the canopy door.

6.32) Turn the interior light to the "II" position that the interior light turns off when the door is closed.

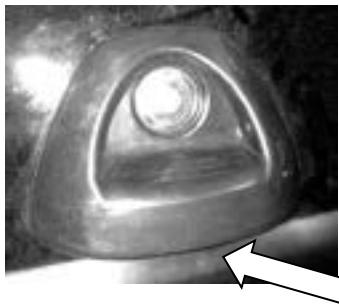

Press the button underneath to check the door releases on the actuator and the pressure is not too high to stop it unlatching.

6.33) 2 people are required for this step. Check the gap on the rear door on the sides of the glass is even to the canopy shell. This can be made even by pushing in on the canopy shell rear pillars and on the inside loosening and doing up the screws.

6.34) It may be necessary now to adjust the canopy backwards to reduce the pressure on the lower door edge seal and therefore the door actuator mechanism. This will allow the door to open properly and evenly both sides.

2 people will be required to re-adjust the door glass gap at the sides if the canopy has to be moved.



6.35) Check the gap of the canopy shell's trim edge corners to the tub. It should be even on both sides of the canopy.

!! IMPORTANT !! The gap must not be below 5mm. Move the canopy rearward if required

If there are issues with the rear door operation being uneven on each side, refer to Section 7.

Tighten the Torx screws through the rear corner brackets to 20 Nm to secure the canopy's position.

Not to be less than 6mm

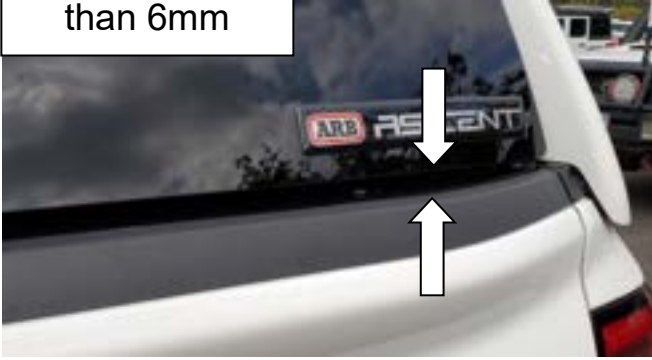

6.36) Position the canopy so the lower rear door glass edge's sash seal is sealing well and evenly along its length to the tailgate door stop extrusion assembly mounted on the tailgate. **Measure with a ruler vertically between the door glass lower edge to the top of the tailgate tub stop bracket. (This distance must not be less than 6mm and should be even). 9mm is nominal condition.**







6.37) Water test the canopy around all windows and joins to the tub with high pressure hose and seal or report any leaks found.

6.38) **Ensure Section 7 of these instructions including the second last page of this instruction are discussed with the customer and are given to the customer.**

SECTION 7: OPERATIONAL CHECKS AND ADJUSTMENT OF DOORS AND WINDOWS

Operational checks need to be undertaken as follows.

	<p>7.1) Move the interior light switch to the position II where it will turn off when the door is closed and turn on when the door is opened.</p>
	<p>7.2) Depress the vehicle's brake pedal and have a second person check that the brake light in the spoiler works.</p>
	<p>7.3) Remove the key from the rear door handle and combine this with the key taped inside the canopy. The 2 keys should then be added to the customer's key ring. <u>!! IMPORTANT !! Check BOTH keys work manually in the rear door lock.</u></p>
	<p>7.4) Operate the door push button switch to open and close the door. If one side opens before the other, the lock mechanism can be adjusted so that both sides of the door open simultaneously if the following is done:</p> <ul style="list-style-type: none"> • Open the door. Remove the 4 scriveners retaining the lower section of the door interior cover using a flat blade screw driver under the head. Slightly pry the door cover down away from the glass. • Close both of the latch pawls on the sides of the door glass with your fingers. Slowly turn the interior door release handle and listen to hear if both latches click open at the same time with the door cover pushed back up to the glass whilst ensuring the latch rods are located into the foam blocks on the door cover.

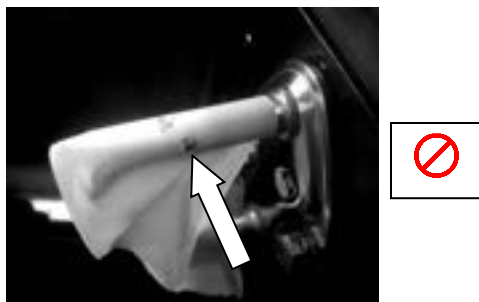
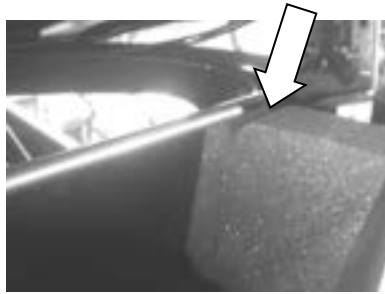
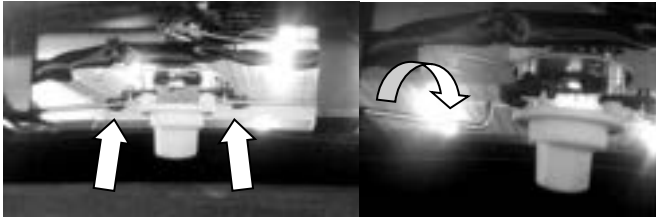

- If the latches do not operate simultaneously, locate the black plastic clips on each end of the pull rods to the latches, unclip a pull rod, lengthen or shorten it by winding it in/out and re-clip in. Close the latches with your fingers again and test operation via the interior rear door handle to operate simultaneously.
- Once satisfied, refit the door cover lower portion with the scrivenets, but ensure to guide the pull rods into slits in the foam blocks on the door cover at both ends.

If the latches can be seen to bind on the door frame strikers, it may be necessary to adjust the door frame strikers.

Do this by the following:

- Place one thickness of masking tape around the striker bar where the latches contact. Open and close the door. If the tape shown signs of wear through on the top side or underneath of the striker bar, it is necessary to adjust the striker away from the side on which the wear is shown. **The aim is only to have wear on the outward face of the striker bar.**
- Undo the M6 screws slightly on the strikers and adjust their position slightly. **Re-torque screws to 9Nm.**
- Test the door again and adjust via the above methods until satisfied.

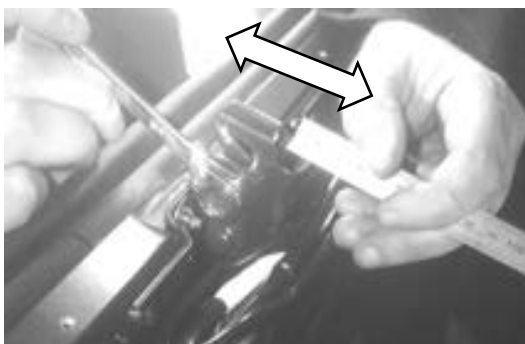
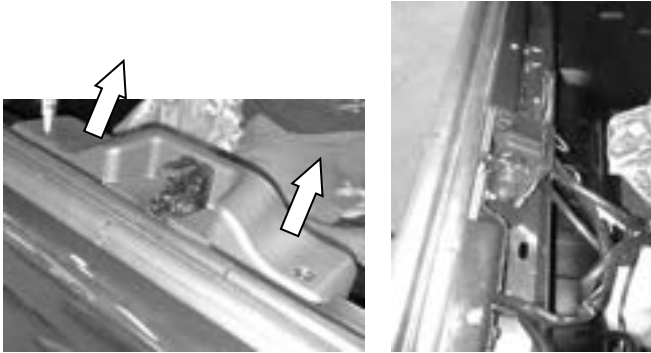

7.5) Operate the push button switch on side lift up windows. If the windows will not latch properly, and the solenoid can be heard working, the latch can be adjusted in the following steps.

- Remove the rotary latch cover on the window frame.
- Operate the window with a person outside pushing the button and closing the window slowly. Look to see the striker bar on the glass does not scuff the leg on the rotary latch pawl as the window closes. The striker bar should close into the middle of pawl slot on the rotary latch on the frame. Place one thickness of masking tape around the striker bar where the latch contacts. Open and close the window. If the tape shows signs of wear through on the top or underside of the striker bar, it is necessary to adjust the striker away from the side on which the wear is shown. **The aim is only to have wear on the outward side of the striker bar not above or below in closed position.**
- Two M6 Torx screws can be undone with T30 bit and **re-tightened to 7Nm** on the glass mounted striker on either side to move the position of the striker up and down on the glass.
- The rotary latch on the window frame provides window in/out adjustment. Measure the distance between the back of the rotary latch and it's mounting bracket and take note of it (9mm). Loosen the bolts through the latch and move the latch out 1mm at a time and **re-tighten to 9Nm** and test the window until it opens and closes and seals satisfactorily.
- Refit the cover over the latch mechanism and ensure wiring inside is coiled up neatly and cannot interfere with the latch mechanism.

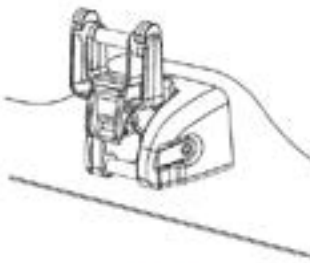
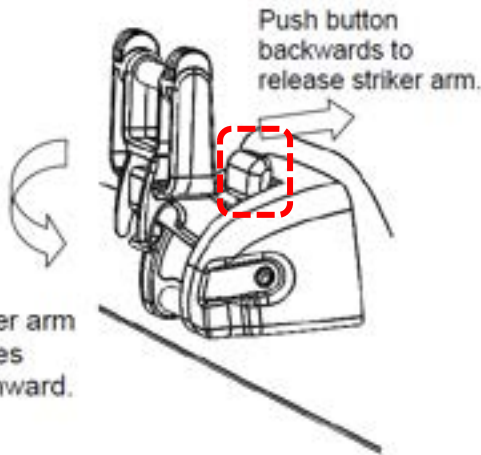
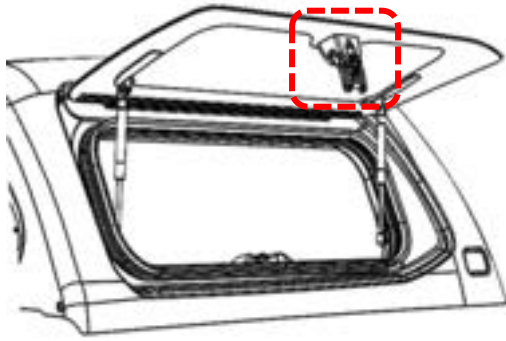

Striker in (up) window closed position.

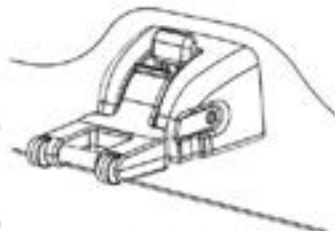

Striker in (down) window open position. (Vented window)

7.6) The lift up side windows incorporate a catch design that allows two positions of operation.

With the striker arm up, the window will fully close to seal. With the striker arm down, the window may be locked in a partially open, air vented position, to allow air flow inside the canopy for pets.

To configure the striker into the partially open (window vented position), push the release button backwards on the catch, and rotate latch arm down until it locks into open position (vented window).

To fold the arm up and close the window, simply push latch arm upwards until arm “clicks” into the up position.

Do not close the window unless the striker latch arm is locked in either up or down positions.

If latch arm is not locked in position during closing of the window, it could cause damage to the striker and / or the rotary latch mechanism.



SECTION 8: OWNERS MANUAL SUPPLEMENT (Fill in and give to customer).

ARB - Ascent Canopy AC24C Ford Ranger 2022+

KEY CODE (Write it in boxes opposite)

L				
---	--	--	--	--

Warranty

- Refer to ARB Products “Warranty Against Defects” booklet contained within the hardware kit, to be delivered to the customer upon purchase.
- ARB provides a 3 year warranty with this product from date of purchase via the original purchaser.
- One year warranty is provided on gas struts.
- This warranty does not cover modifications / alterations, improper installation, use of non-genuine ARB accessories, abuse / misuse, accident, lack of maintenance, normal wear and tear and exposure to chemicals or solvents harmful to plastics.
- Loss of contents within the tub and canopy due to use, breakage during theft, leaving the canopy unlocked, lack of maintenance or mis-use of the product is the responsibility of the vehicle operator.
- Normal wear and tear from the vehicle’s operation with the canopy can occur and paint rub result on the canopy or the tub over time. It is recommended that the customer observes wear on tailgate protection tape and periodically replaces it.

Safety Warnings

- **The canopy will only unlock on the remote key fob when the unlock button is pressed twice.**
- Do not drive with windows or doors open, other than on the latch position for providing a vented side lift up window. All doors and lift up windows should remain closed and latched.
- Do not sit, rest or stand on the canopy roof, or rest heavy objects on the roof without these being loaded on ARB genuine roof bars or racks systems.
- Do not fit any roof bar or roof rack system other than ARB genuine accessories designed for this canopy.
- Do not use the vehicle’s tub with a canopy fitted as a passenger compartment.
- Do not transport or store volatile materials such as solvents, chemicals or liquids, as fumes may cause damage inside the canopy, or cause fire, due to reduced ventilation.
- Do not fill fuel containers inside the canopy as static electricity can build up causing a fire.
- Do not allow solvents, chemicals or oils to contact the canopy as damage can occur. Clean interior canopy surfaces with water and mild detergent.
- Do not depress lift up window or rear door push button switches for a period of time other than to function their operation. Do not operate them simultaneously, as damage may result. Overload switches on locking systems should reset after 30 seconds.

Maintenance Requirements

- At routine vehicle service schedules, screw torques as described in this fitting instruction should be checked. (Please ask the company that fitted your canopy for a copy of the fitting instructions).
- At routine vehicle service schedules, or as conditions dictate, lubricate the handle lock with Teflon spray e.g. SuperLube multipurpose Aerosol or 3-in-1 Professional Lock Lubricant or Isoflex Topas L32 grease. Latches and hinges may be serviced with Isoflex Topas L32 grease. Vaseline may be used sparingly on rotary latches. Molybond 122 on hinges. Do NOT use any other greases, oils or aerosols as failure may result voiding warranty.
- Ensure functional checks of the rear door lift up windows, interior light 3 way switch on door opening and brake light are carried out at vehicle service schedules.
- To clean, only use quality car care mild detergents, waxes and polishes. Do not use abrasive compounds on painted surfaces unless conducting repairs. If paint repairs are undertaken only bake at 60oC. Use only paint systems that are suitable for ABS plastic.
- Ensure gas struts are only ever connected with the cylinder end to the glass and the rod end to the canopy’s window frames. Failure to do so will cause premature failure of gas struts.
- Clean gas strut rods with a damp cloth only when regularly cleaning the vehicle. Seal failure of the strut can occur if cleaned with solvents or greased or left uncleaned.

**SECTION 9: ARB FITMENT CHECKLIST (TO BE FILLED IN - RETAIN THIS RECORD).**

To be completed by the installer and records kept at the dealer or fitter.

ARB - Ascent Canopy AC24C Ford Ranger 2022+			
Dealer Name and code:		Date:	
Vehicle registration:		Vehicle Vin No:	
Vehicle make:			
Number of Kms:		Order No:	
Canopy serial number: (left inside corner on canopy pillar on inside of ARB badge recess)			
Canopy Key Serial No (Printed on bag stating with letter L)	L_____	Canopy Colour:	
Vehicle damage / condition check (details):			
			(Tick)
Vehicle tub sealing is done as per Section 1 and the rear tailgate door stop extrusion assembly is fitted correctly as per Section 2.			
Door lower sash seal contacts the tailgate tub stop assembly evenly and there is not less than a 6 mm gap between the lower edge of the glass and the top of the tailgate all the way along it. The gap should look even all the way along the edge of the glass.			
All screw torques completed as detailed in the instructions – ! Important !			
Rear door gaps down the sides are aligned to canopy shell, and door latches both sides simultaneously on closing and releases simultaneously on opening. (See Section 5,6)			
Key fob once pressed, unlocks the canopy. (twice pressed once first connected to reset the system)			
Door rear door push button switch functions to open the door both sides simultaneously.			
Door functions with both keys to turn to open as a manual electrical failsafe.			
3-way position interior light switch is set to come on with door open.			
Lift up windows operate via push button to unlatch to open and will close and latch manually.			
Lift up windows latch arm when opened on the striker will latch and unlatch from the window frame when the push buttons are operated to open and will close and latch manually to lock in the vented window position.			
The roof vent functions and water seals.			
Water test with high pressure hose has been completed around all windows and join to canopy bed and at the roof vent with no leaks other than through unsealed tailgate sides.			
Spoiler rear brake light operates when brake pedal is pressed and any cabin mounted rear brake light on the vehicle does not operate any more.			
Canopy keys added to customer's key ring.			
Serial number recorded on the owner's supplement pages and owner's manual supplement copy given to the customer and explained.			
Comments:			
Fitted by:			
Checked by:			